



PRODUCT CATALOG 2026



www.balticwelders.ee

BW
Baltic Welders

TABLE OF CONTENTS

- | | | | |
|---|---|---|---|
|  | 2 DIGGING BUCKETS
<i>For machines weighing 1-8t</i> |  | 16 HARDOX SIEVING BUCKETS
<i>For machines weighing 18-30t</i> |
|  | 3 DIGGING BUCKETS
<i>For machines weighing 13-40t</i> |  | 17 FRONTAL SIEVING BUCKETS
<i>1000-1400L</i> |
|  | 4 CABLE BUCKETS
<i>For machines weighing 1-8t</i> |  | 18 SNOWBUCKETS
<i>For snow 700-1500l</i> |
|  | 5 CABLE BUCKETS
<i>For machines weighing 12-22t</i> |  | 19 LIGHT MATERIAL BUCKETS
<i>For grain 1600-7000l</i> |
|  | 6 STATIC PLANNING BUCKETS
<i>For machines weighing 2-8t</i> |  | 20 LIGHT MATERIAL BUCKETS
<i>1100-1500l</i> |
|  | 7 HARDOX PLANNING BUCKETS
<i>For machines weighing 13-28t</i> |  | 21 GRAVEL BUCKETS
<i>600-1400l</i> |
|  | 8 HYDRAULIC PLANNING BUCKETS
<i>For machines weighing 2-8t</i> |  | 22 GRAVEL BUCKETS
<i>2000-5000l</i> |
|  | 9 HARDOX HYDRAULIC PLANNING BUCKETS
<i>For machines weighing 13-35t</i> |  | 23 EXCAVATOR BACK BUCKETS
<i>For machines weighing 2-13t</i> |
|  | 10 HYDRAULIC PLANNING BUCKETS
<i>For machines weighing 15-20t</i> |  | 24 SIDE TIP BUCKETS
<i>800-1000l</i> |
|  | 11 STATIC SIEVE PLANNING BUCKETS
<i>For machines weighing 16-24t</i> |  | 25 V-LINE BUCKETS
<i>For machines weighing 1-8t</i> |
|  | 12 HYDRAULIC SIEVE PLANNING BUCKETS
<i>For machines weighing 16-24t</i> |  | 26 V-LINE BUCKETS
<i>For machines weighing 13-26t</i> |
|  | 13 ROTATOR BUCKETS
<i>For machines weighing 1-8t</i> |  | 27 V-LINE BUCKETS
<i>For machines weighing 16-26t</i> |
|  | 14 ROTATOR BUCKETS
<i>For machines weighing 13-24t</i> |  | 28 V-LINE HYDRAULIC BUCKETS
<i>For machines weighing 16-20t</i> |
|  | 15 SIEVING BUCKETS
<i>For machines weighing 2-24t</i> |  | 29 STATIC QUICK S-TYPE COUPLINGS |



30 STATIC QUICK COUPLINGS



31 TILTING QUICK COUPLINGS S-TYPE



32 S-TYPE COUPLINGS



33 NTP TYPE COUPLINGS



34 COUPLINGS FOR LOADERS



35 FRONTAL QUICK COUPLERS FOR LOADERS



36 FRONTAL QUICK COUPLERS



37 ADAPTERS FOR HAMMERS



38 ADAPTERS FOR HAMMERS



39 ADAPTERS



40 ADAPTERS FOR EQUIPMENT



41 DIGGING BUCKET THUMB
For machines weighing 3-24t



42 HOOKS
For machines 2-45t



43 STUB CRUSHERS



44 STUB CRUSHERS WITH GRAPPLE



45 RAKES



46 HYDRAULIC FOREST RAKES



47 STUB FLIPPER



48 PALLET FORKS



49 GRADING BARS
For machines weighing 8-22t



50 GRADING FRAME



51 ASFALT CUTTERS



52 LIFTING BOOMS



53 FRONT GUARDS



54 ROOF GUARDS

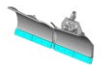

55 V-PLOUGHS



56 ROAD SNOW PLOUGHS



57 SNOW PLOUGH EXTRAS

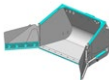

58 SNOW BUCKET WITH WINGS



59 U-PLOUGHS



60 ZOOM-PLOUGHS



61 CHAIN MULCHER



62 DEMOLITION GRAPPLES



63 LOG GRAPPLES

DIGGING BUCKETS

For machines weighing 1-8t

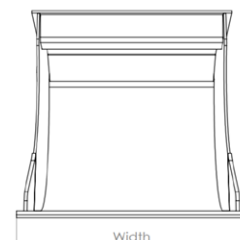
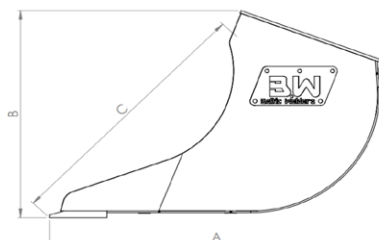
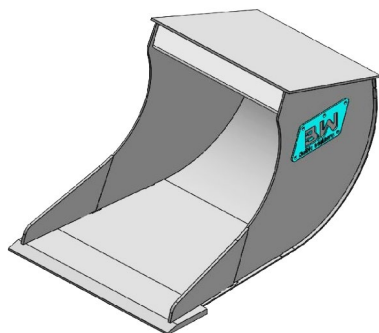

Product	Machine, weight, t	Capacity, l	Capacity with heap, l	A, mm	B, mm	C, mm	Width, mm	Weight, kg	Teeth
DB35	<1	35	55	596	397	469	480	35	-
DB35T	<1	35	55	596	397	469	480	40	4
DB40	<2	40	60	757	493	624	400	45	-
DB40T	<2	40	60	757	493	624	400	50	3
DB60	<2	60	80	757	493	624	500	50	-
DB60T	<2	60	80	757	493	624	500	55	4
DB70	<3	70	90	757	493	624	550	55	-
DB70T	<3	70	90	757	493	624	550	60	4
DB80	<3	80	100	757	493	624	600	60	-
DB80T	<3	80	100	757	493	624	600	65	4
DB100	<4	100	140	965	655	808	500	100	-
DB100T	<4	100	140	965	655	808	500	115	4
DB130	<5	130	180	965	655	808	600	120	-
DB130T	<5	130	180	965	655	808	600	135	4
DB150	<6	150	220	1166	784	992	600	160	-
DB150T	<6	150	220	1166	784	992	600	180	4
DB180	<6	180	220	965	655	808	800	140	-
DB180T	<6	180	220	965	655	808	800	155	4
DB200	<7	200	270	1166	784	992	700	190	-
DB200T	<7	200	270	1166	784	992	700	210	4
DB250	<8	250	320	1166	784	992	800	220	-
DB250T	<8	250	320	1166	784	992	800	240	4

DIGGING BUCKETS

For machines weighing 13-40t

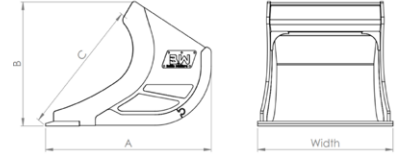
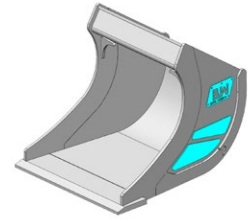

Product	Machine, weight, t	Capacity, l	Capacity with heap, l	A, mm	B, mm	C, mm	Width, mm	Weight, kg	Teeth
DB300	<13	300	400	1232	910	1000	850	390	-
DB300T	<13	300	400	1232	910	1000	850	415	4
DB350	<14	350	450	1232	910	1000	1000	430	-
DB350T	<14	350	450	1232	910	1000	1000	455	4
DB350K	<14	350	450	1382	1000	1190	600	355	-
DB350KT	<14	350	450	1382	1000	1190	600	380	4
DB400	<16	400	500	1382	1000	1190	850	490	-
DB400T	<16	400	500	1382	1000	1190	850	515	4
DB600	<18	600	700	1382	1000	1190	950	530	-
DB600T	<18	600	700	1382	1000	1190	950	555	4
DB700	<20	700	820	1465	1070	1226	1000	735	-
DB700T	<20	700	820	1465	1070	1226	1000	765	4
DB950	<22	950	1070	1465	1070	1226	1200	800	-
DB950T	<22	950	1070	1465	1070	1226	1200	830	4
DB900	<20	950	1070	1720	1390	1590	1050	1170	-
DB900T	<20	950	1070	1720	1390	1590	1050	1200	4
DB1000	<24	1000	1200	1720	1390	1590	1200	1050	-
DB1000T	<24	1000	1200	1720	1390	1590	1200	1130	4
DB1200	<28	1200	1500	1720	1390	1590	1400	1270	-
DB1200T	<28	1200	1500	1720	1390	1590	1400	1350	4
DB1350	<30	1500	1800	1720	1390	1590	1500	1550	-
DB1350T	<30	1500	1800	1720	1390	1590	1500	1650	5
DB1500	<30	1500	1800	1720	1390	1590	1600	1550	-
DB1500T	<30	1500	1800	1720	1390	1590	1600	1650	5
DB-1500HA	<30	1500	1800	1720	1390	1590	1640	1800	-
DB1500H	<30	1500	1800	1720	1390	1590	1640	1800	4
DB1700	<35	1700	2200	1968	1400	1627	1600	1900	-
DB1700T	<35	1700	2200	1968	1400	1627	1600	2050	4
DB1900	<40	1900	2500	1968	1400	1627	1800	2150	-
DB1900T	<40	1900	2500	1968	1400	1627	1800	2300	5
DB2100	<40	2100	2800	1968	1400	1627	2000	2400	-
DB2100T	<40	2100	2800	1968	1400	1627	2000	2550	5

CABLE BUCKETS

For machines weighing 2-8t

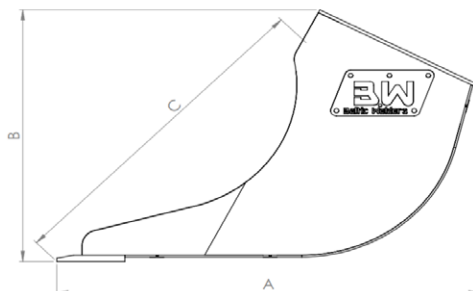
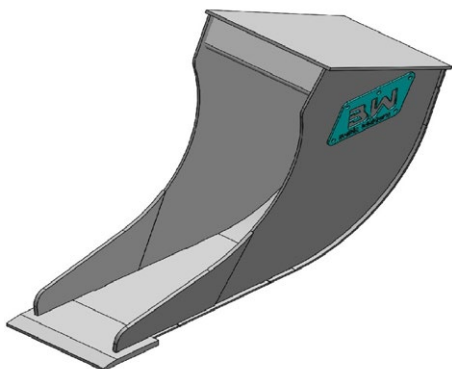

Product	Machine, weight, t	Capacity, l	Capacity with heap, l	A, mm	B, mm	C, mm	D, mm	Width, mm	Weight, kg	Teeth
CB40	<2	40	55	867	513	736	300	300	45	-
CB55	<3	55	70	867	513	736	418	300	50	-
CB55T	<3	55	70	867	513	736	418	300	55	2
CB70	<3	70	85	867	513	736	465	350	60	-
CB70T	<3	70	85	867	513	736	465	350	70	2
CB85	<4	85	100	867	513	736	518	400	75	-
CB85T	<4	85	100	867	513	736	518	400	85	4
CB100	<5	100	125	1050	670	900	400	300	95	-
CB100T	<5	100	125	1050	670	900	400	300	105	2
CB120	<6	120	150	1050	670	900	400	400	105	-
CB120T	<6	120	150	1050	670	900	400	400	115	2
CB130	<7	130	160	1239	825	1062	400	300	120	-
CB130T	<7	130	160	1239	825	1062	400	300	130	2
CB140	<8	140	170	1239	825	1062	450	350	130	-
CB140T	<8	140	170	1239	825	1062	450	350	140	2
CB150	<8	150	180	1239	825	1062	450	400	140	-
CB150T	<8	150	180	1239	825	1062	450	400	150	3
CB160	<8	160	190	1239	825	1062	635	400	160	-
CB160T	<8	160	190	1239	825	1062	635	400	170	3

CABLE BUCKETS

For machines weighing 12-22t

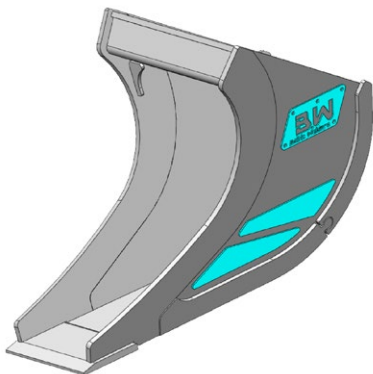

Product	Machine, weight, t	Capacity, l	Capacity with heap, l	A, mm	B, mm	C, mm	D, mm	Width, mm	Weight, kg	Teeth
CB220	<12	220	300	1385	990	1182	685	400	400	-
CB220T	<12	220	300	1385	990	1182	685	400	430	3
CB220P	<12	220	300	1585	980	1282	685	400	375	-
CB220PT	<12	220	300	1585	980	1282	685	400	405	3
CB300	<14	300	380	1385	990	1182	775	500	450	-
CB300T	<14	300	380	1385	990	1182	775	500	480	3
CB320	<18	320	400	1465	1060	1225	685	400	520	-
CB320T	<18	320	400	1465	1060	1225	685	400	550	3
CB370	<20	370	450	1465	1060	1225	775	500	560	-
CB370T	<20	370	450	1465	1060	1225	775	500	590	3
CB400	<22	400	600	1465	1060	1225	775	600	540	-
CB400T	<22	400	600	1465	1060	1225	775	600	600	4



STATIC PLANNING BUCKETS

For machines weighing 2-8t

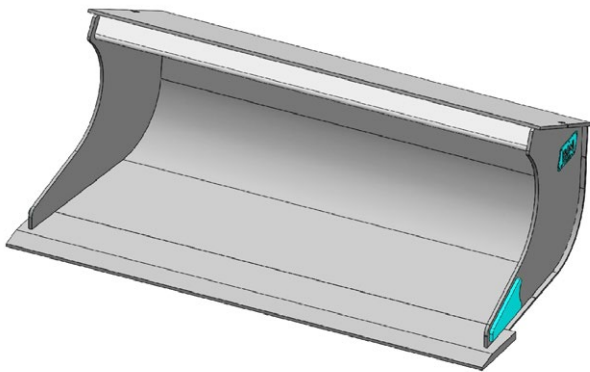

Product	Machine weight, t	Capacity, l	Capacity with heap, l	A, mm	B, mm	C, mm	Width, mm	Weight, kg
PB40	<1	40	60	495	290	374	800	50
PB60	<2	60	80	495	290	374	1000	60
PB80	<3	80	100	495	290	374	1200	75
PB100	<4	100	120	495	290	374	1400	90
PB140	<5	140	180	660	420	520	1200	120
PB150	<5	150	190	660	420	520	1300	130
PB180	<6	180	230	660	420	520	1500	150
PB240W	<8	240	380	660	420	520	2000	200
PB300W	<8	240	380	660	420	520	2500	240
PB190	<5	190	250	803	582	686	1200	240
PB240	<6	240	300	803	582	686	1300	255
PB320	<8	320	380	803	582	686	1500	285

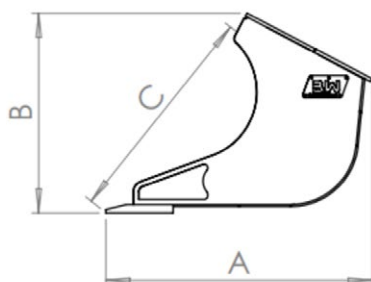

HARDOX PLANNING BUCKETS

For machines weighing 13-28t

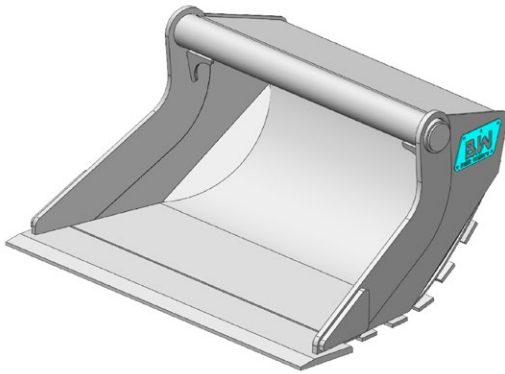

Product	Machine weight, t	Capacity, l	Capacity with heap, l	A, mm	B, mm	C, mm	Width, mm	Weight, kg	Material
PB450HD	<13	400	550	1175	712	880	1500	410	Full Hardox
PB550HD	<15	500	650	1175	712	880	1750	465	Full Hardox
PB500HD	<15	500	800	1385	868	1170	1500	520	Full Hardox
PB600HD	<15	600	1000	1385	868	1170	1650	580	Full Hardox
PB650HD	<15	600	800	1175	712	880	2000	530	Full Hardox
PB700HD	<16	700	1100	1385	868	1170	1800	650	Full Hardox
PB800HD	<18	800	1200	1385	868	1170	1950	740	Full Hardox
PB900HD	<20	900	1300	1385	868	1170	2100	850	Full Hardox
PB1000HD	<22	1000	1400	1525	925	1320	1900	950	Full Hardox
PB1100HD	<24	1100	1500	1525	925	1320	2100	1050	Full Hardox
PB1300HD	<28	1300	1700	1525	925	1320	2300	1200	Full Hardox
PB1800HD	<40	1800	2200	1625	1200	1420	2300	1500	Full Hardox

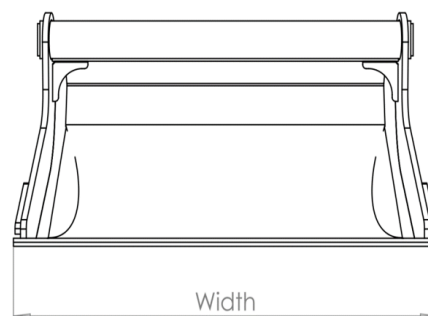
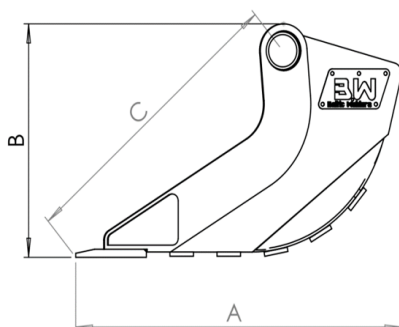

HYDRAULIC PLANNING BUCKETS

For machines weighing 2-8t

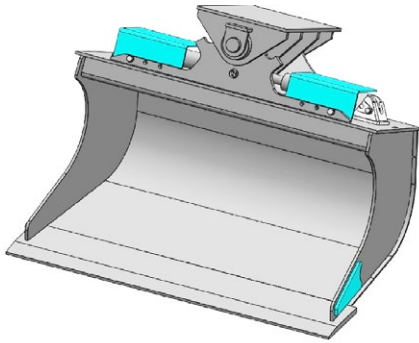

Product	Machine weight, t	Capacity, l	Capacity with heap, l	A, mm	B, mm	C, mm	Width, mm	Weight, kg	Cylinders
PB40H	<1	40	60	495	290	374	800	75	1 (H)
PB60H	<2	60	80	495	290	374	1000	85	1 (H)
PB80H	<3	80	100	495	290	374	1200	100	1 (H)
PB100H	<4	100	120	495	290	374	1400	115	1 (H)
PB140H	<5	140	180	660	420	520	1200	160	1 (H)
PB140H-SIL	<5	140	180	660	420	520	1200	160	2 (H)
PB150H	<5	150	190	660	420	520	1300	170	1 (H)
PB150H-SIL	<5	150	190	660	420	520	1300	170	2 (H)
PB180H	<6	180	230	660	420	520	1500	200	1 (H)
PB180H-SIL	<6	180	230	660	420	520	1500	200	2 (H)
PB190H	<5	190	250	803	582	686	1200	240	2 (H)
PB240H	<6	240	300	803	582	686	1300	255	2 (H)
PB320H	<8	320	380	803	582	686	1500	285	2 (H)

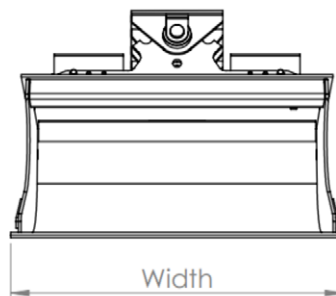
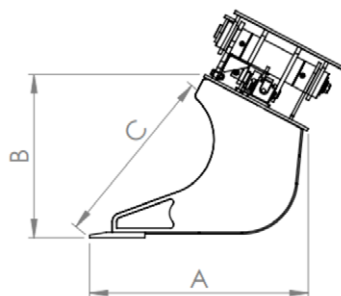

Tilting angle is 45° + 45°
H - Horizontal cylinders

HARDOX HYDRAULIC PLANNING BUCKETS

For machines weighing 13-35t

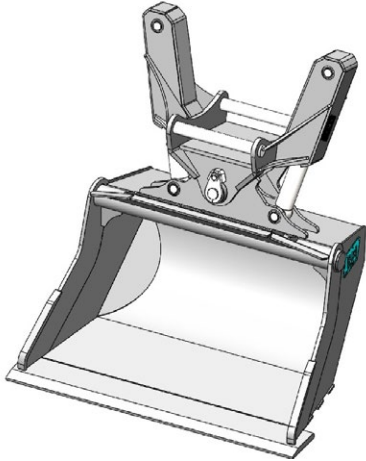

Product	Machine weight, t	Capacity, l	Capacity with heap, l	A, mm	B, mm	C, mm	Width, mm	Weight, kg	Cylinders
PB450VH	<13	400	550	1175	712	860	1500	625	1 (VH)
PB550VH	<15	500	650	1175	712	860	1750	685	1 (VH)
PB600VH	<15	600	1000	1390	868	1170	1650	750	1 (VH)
PB650VH	<15	600	800	1175	712	860	1750	750	1 (VH)
PB700VH	<16	700	1100	1390	868	1170	1800	850	1 (VH)
PB800VH	<18	800	1200	1390	868	1170	1950	1000	2 (VH)
PB900VH	<20	900	1300	1390	868	1170	2100	1150	2 (VH)
PB1000VH	<22	1000	1400	1550	1050	1320	1900	1650	2 (VH)
PB1100VH	<24	1100	1500	1550	1050	1320	2100	1800	2 (VH)
PB1300VH	<28	1300	1700	1550	1050	1320	2300	1950	2 (VH)
PB1400VH	<35	1400	2000	1390	868	1170	3000	2400	2 (VH)
PB1800VH	<40	1800	2200	1625	1200	1420	2300	2550	2 (VH)

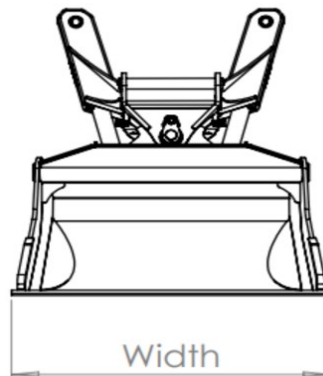
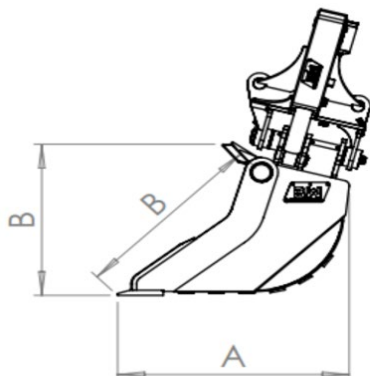

Tilting angle is 45° + 45°
VH - Vertical hidden cylinders

HYDRAULIC PLANNING BUCKETS

For machines weighing 15-20t

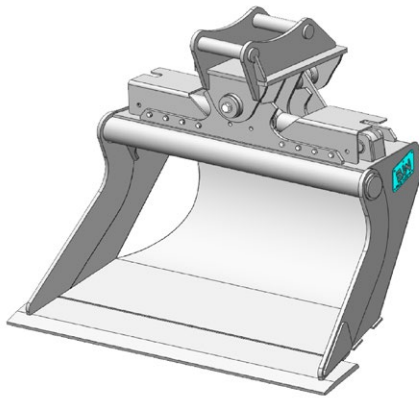

Product	Machine weight, t	Capacity, l	Capacity with heap, l	A, mm	B, mm	C, mm	Width, mm	Weight, kg	Cylinders
PB550H	<15	500	650	1175	712	860	1750	665	2 (HH)
PB600H	<15	600	1000	1390	868	1170	1650	730	2 (HH)
PB700H	<16	700	1100	1390	868	1170	1800	830	2 (HH)
PB800H	<18	800	1200	1390	868	1170	1950	980	2 (HH)
PB900H	<20	900	1300	1390	868	1170	2100	1130	2 (HH)

Tilting angle is 40° + 40°

HH - Horizontal cylinders

Possible to order full hardox buckets

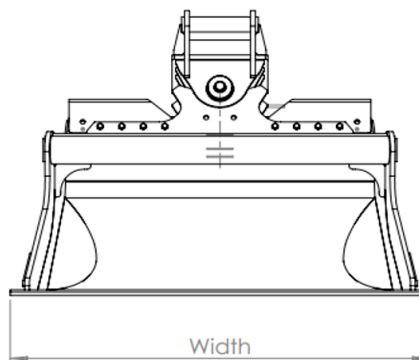
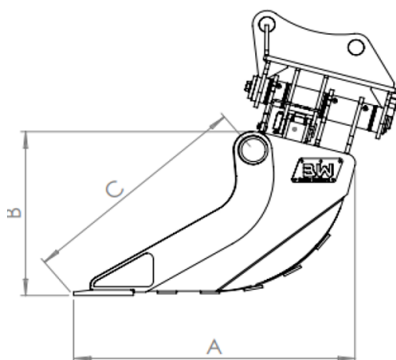

STATIC SIEVE PLANNING BUCKETS

For machines weighing 16-24t

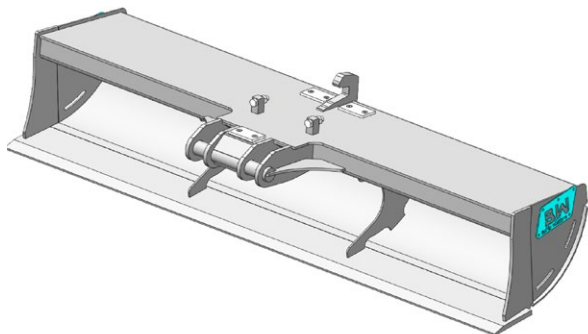

Product	Machine weight, t	Capacity, l	Capacity with heap, l	A, mm	B, mm	C, mm	Width, mm	Weight, kg	Cylinders
PB300S	<10	300	450	712	425	590	2500	300	2 (H)
PB600S	<16	550	800	750	550	600	2500	570	2 (H)
PB650S	<16	650	900	750	550	600	3000	660	2 (H)
PB700S	<20	700	1000	975	750	800	2500	650	
PB800S	<20	800	1100	975	750	800	2800	690	
PB900S	<20	900	1200	975	750	800	3000	730	
PB1000S	<24	1100	1300	1195	750	800	3000	770	

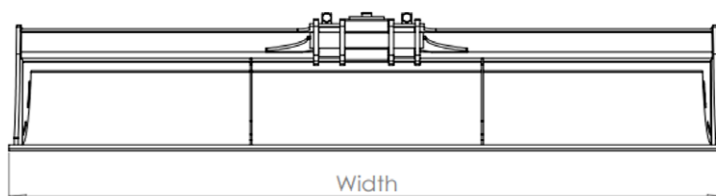
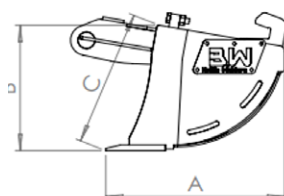

HYDRAULIC SIEVE PLANNING BUCKETS

For machines weighing 16-24t

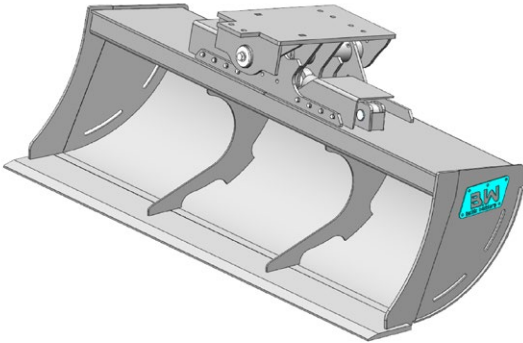

Product	Machine weight, t	Capacity, l	Capacity with heap, l	A, mm	B, mm	C, mm	Width, mm	Weight, kg	Cylinders
PB600HS	<16	550	800	750	550	600	2500	780	2 (H)
PB650HS	<16	650	900	750	550	600	3000	870	2 (H)
PB700HS	<20	700	1000	975	750	800	2500	860	2 (H)
PB800HS	<20	800	1100	975	750	800	2800	900	2 (H)
PB900HS	<20	900	1200	975	750	800	3000	940	2 (H)
PB1000HS	<24	1100	1300	1195	750	800	3000	1000	2 (H)

Tilting angle is 40° + 40°
H - Horizontal cylinders

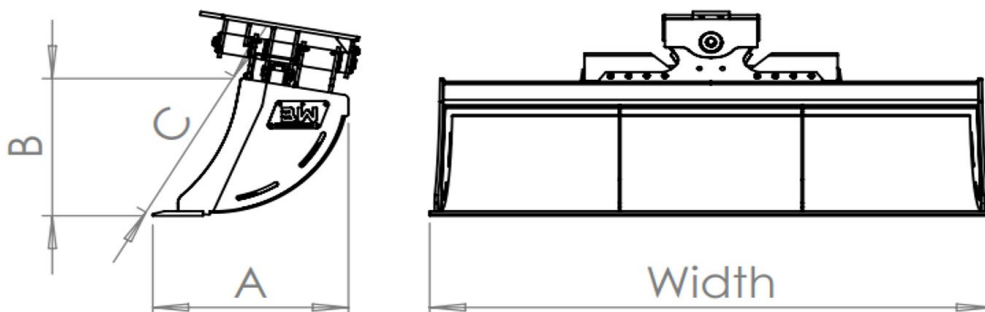

ROTATOR BUCKETS

For machines weighing 1-8t

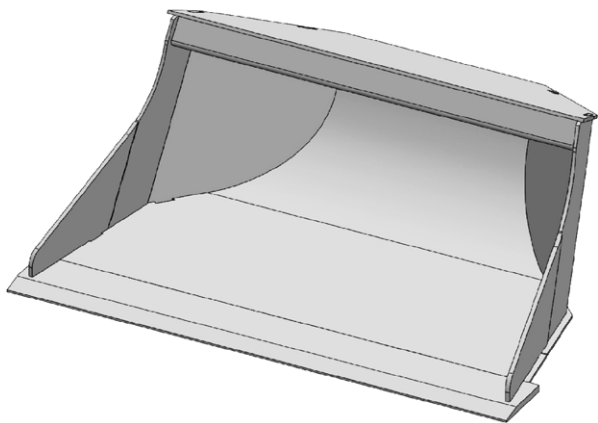

Product	Machine weight, t	Capacity, l	Capacity with heap, l	A, mm	B, mm	C, mm	Width, mm	Weight, kg
RB50	<1,5	50	70	690	355	500	800	45
RB60	<2	60	80	690	355	500	900	50
RB80	<3	80	110	690	355	500	1000	60
RB90	<3,5	90	120	690	355	500	1100	70
RB100	<4	100	150	858	463	695	1000	95
RB150	<5	150	200	858	463	695	1100	105
RB200	<6	200	250	858	463	695	1200	115
RB230	<6	230	300	858	463	695	1300	125
RB320	<6	200	250	858	463	695	1800	180
RB250	<7	250	320	1067	618	799	1300	240
RB300	<8	300	370	1067	618	799	1400	260
RB350	<8	350	420	1067	618	799	1500	280

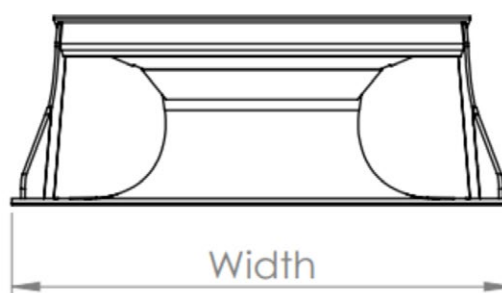
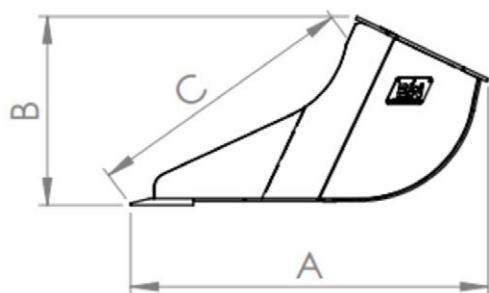

ROTATOR BUCKETS

For machines weighing 13-24t

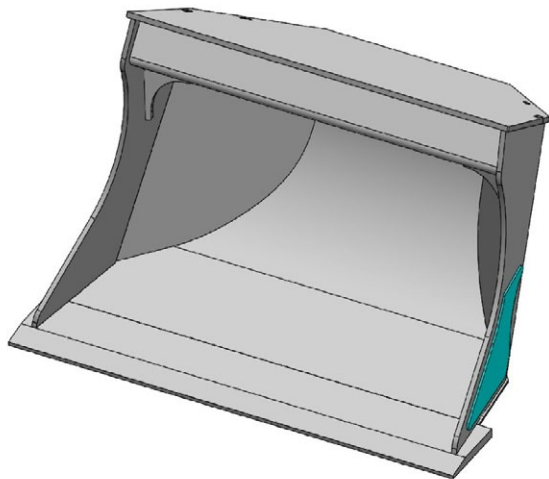

Product	Machine weight, t	Capacity, l	Capacity with heap, l	A, mm	B, mm	C, mm	Width, mm	Weight, kg
RB400W	<13	400	550	1200	779	835	1500	430
RB450W	<13	400	550	1200	779	835	1600	475
RB450	<15	450	550	1267	844	890	1400	430
RB500	<16	500	600	1267	844	890	1600	530
RB800	<20	800	950	1435	993	1062	1600	675
RB900	<22	900	1050	1435	993	1062	1800	750
RB950	<22	950	1100	1435	993	1062	1900	820
RB1000	<24	950	1200	1435	993	1062	2000	900

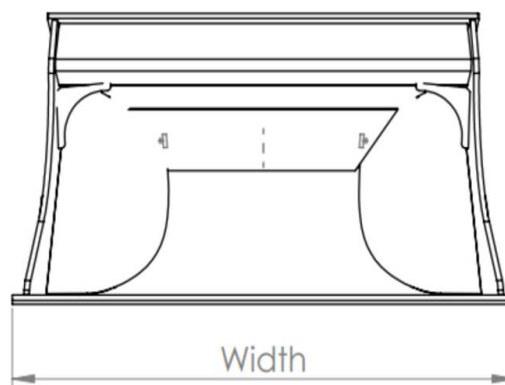
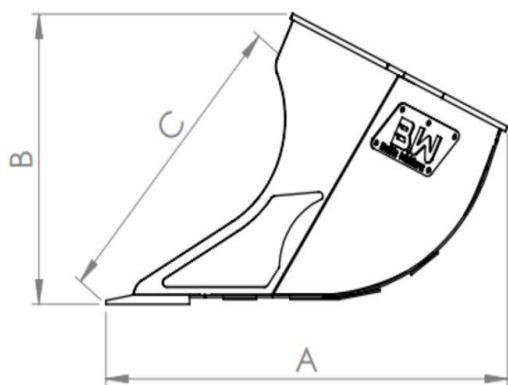

SIEVING BUCKETS

For machines weighing 3-24t

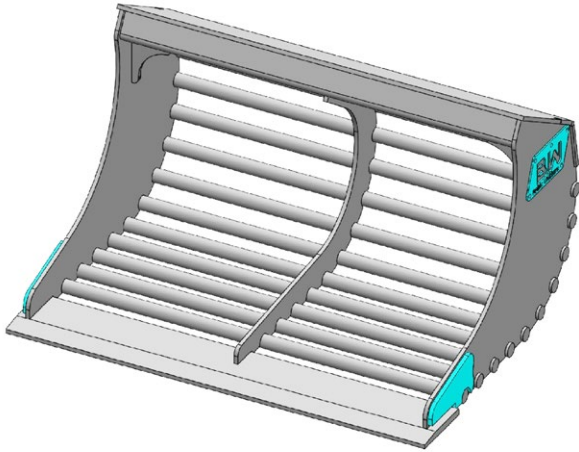

Product	Machine weight, t	Capacity, l	Capacity with heap, l	A, mm	B, mm	C, mm	Width, mm	Weight, kg
SB80	<3	80	100	495	290	374	1200	75
SB150	<5	140	180	660	420	520	1200	120
SB320	<8	320	380	770	593	646	1500	280
SB450	<13	450	600	1068	778	932	1500	550
SB500	<14	450	600	1068	778	932	1600	600
SB700	<18	700	1100	1230	900	1000	1600	670
SB800	<21	800	1200	1230	900	1000	1800	820
SB800LL	<21	800	1200	1230	900	1000	1800	960
SB900	<24	900	1300	1230	900	1000	2000	1010

All models available with removable middle bars

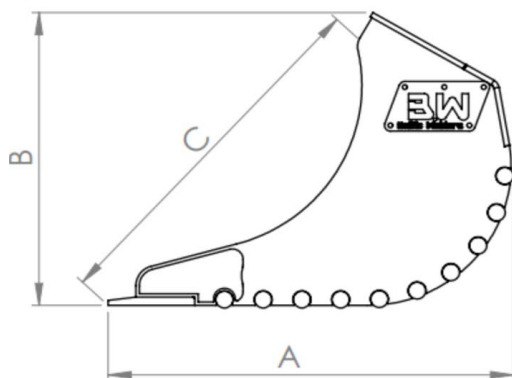

HARDOX SIEVING BUCKETS

For machines weighing 18-30t

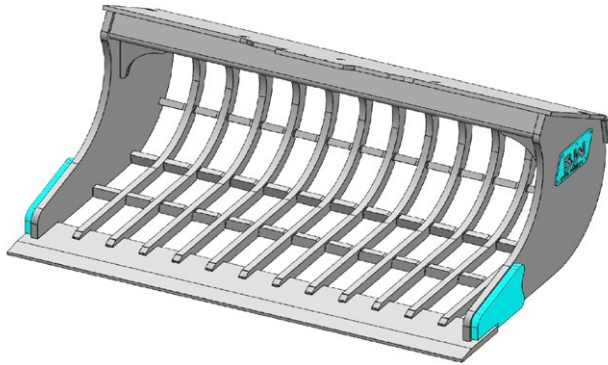

Product	Machine weight, t	Capacity, l	Capacity with heap, l	A, mm	B, mm	C, mm	Width, mm	Teeth	Weight, kg
SB700V	<18	700	1100	1230	900	1000	1600	-	820
SB700VT	<18	700	1100	1230	900	1000	1600	4	860
SB800V	<21	800	1200	1230	900	1000	1800	-	900
SB800VT	<21	800	1200	1230	900	1000	1800	5	960
SB900V	<24	900	1300	1230	900	1000	2000	-	1000
SB900VT	<24	900	1300	1230	900	1000	2000	5	1060
SB1500V	<30	1500	1500	1700	1390	1590	2000	-	2400
SB1500VT	<30	1500	2200	1700	1390	1590	2000	5	2500

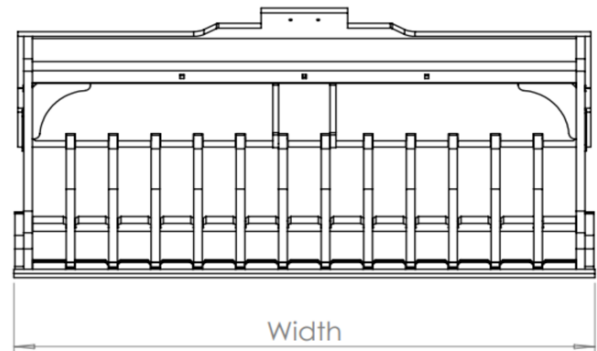
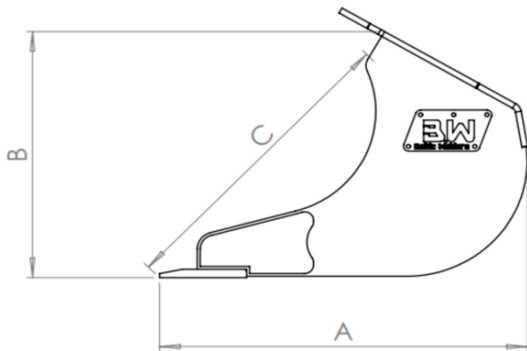

FRONTAL SIEVING BUCKETS

1000-1400l

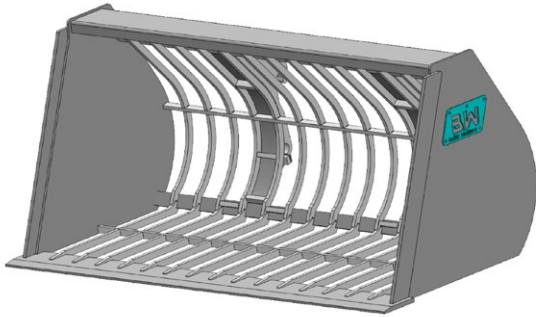

Product	Capacity, l	Capacity with heap, l	A, mm	B, mm	Width, mm	Weight, kg
FSB1000	1000	1200	1100	1040	2000	450
FSB1150	1150	1400	1100	1040	2100	480
FSB1300	1300	1600	1100	1040	2200	500
FSB1400	1400	1700	1100	1040	2300	530

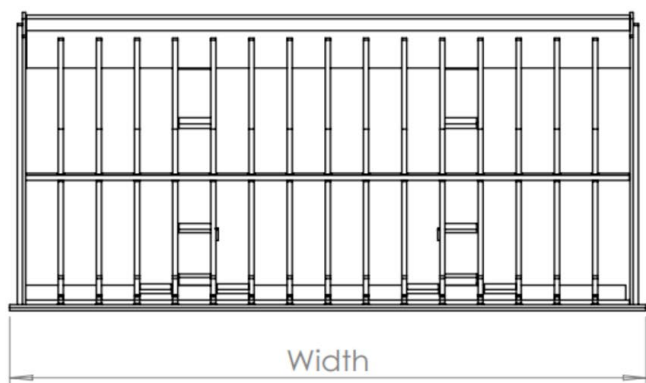
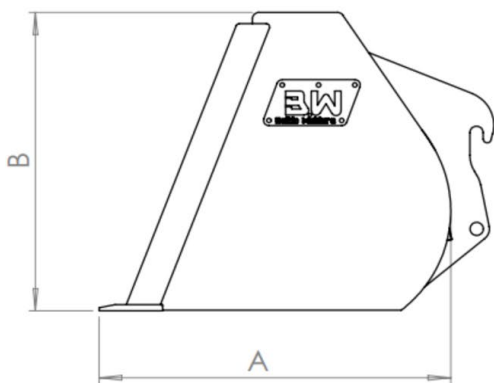

SNOWBUCKETS

For snow 700-1500l

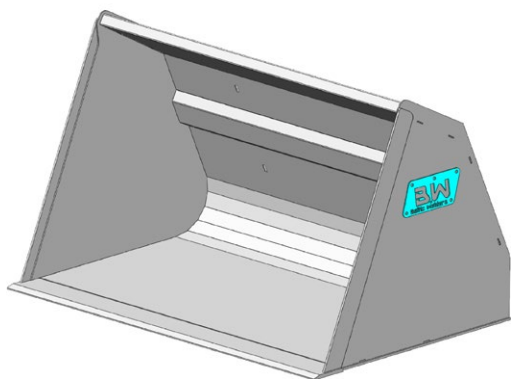

Product	Capacity, l	Capacity with heap, l	A, mm	B, mm	Width, mm	Weight, kg
SN700	700	900	850	900	1600	230
SN1100	1100	1400	1050	1075	1800	300
SN1300	1300	1700	1050	1075	2100	340
SN1500	1500	2000	1050	1075	2400	380

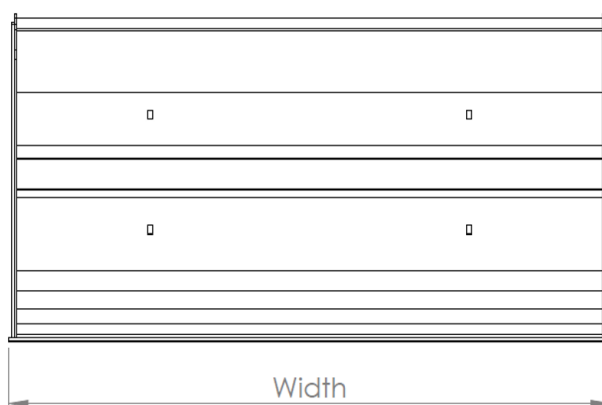
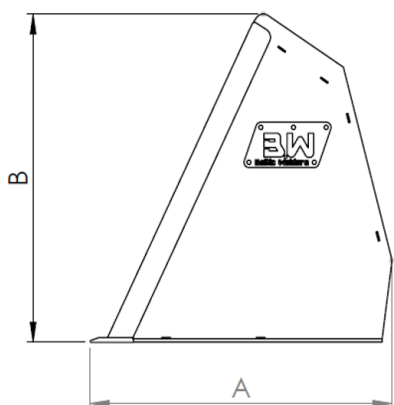

LIGHT MATERIAL BUCKETS

For grain 1600-7000l

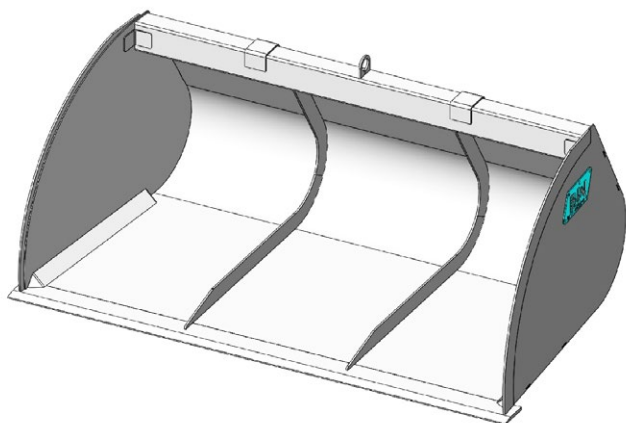

Product	Capacity, l	Capacity with heap, l	A, mm	B, mm	Width, mm	Angle	Weight, kg
LMB1600	1600	1900	1400	1005	2000	10°	370
LMB1700	1700	2000	1400	1005	2100	10°	380
LMB1800	1800	2150	1400	1005	2200	10°	390
LMB1900	1900	2300	1400	1005	2300	10°	400
LMB2000	2000	2400	1500	1005	2400	10°	410
LMB2500	2500	3000	1500	1120	2500	10°	650
LMB3000	3000	3600	1550	1350	2500	10°	830
LMB3400	3400	4000	1550	1350	2750	10°	980
LMB4200	4200	5000	1700	1460	3000	10°	1130
LMB5000	5000	6000	1820	1920	2750	10°	2020
LMB7000	7000	8000	1980	2020	3200	10°	2480

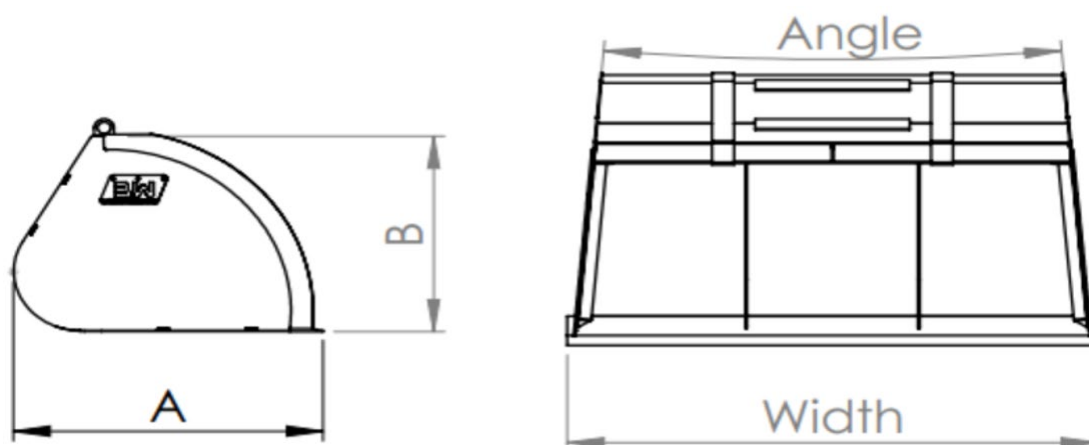

LIGHT MATERIAL BUCKETS

1100-1500l

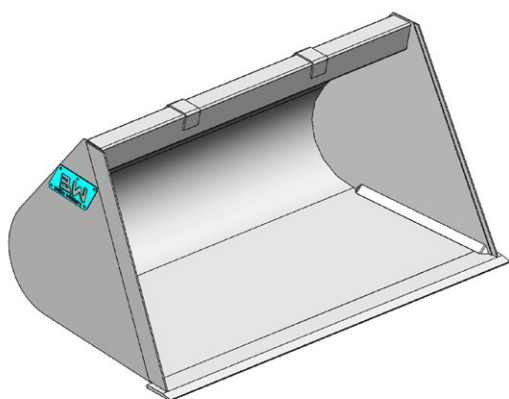

Product	Capacity, l	Capacity with heap, l	A, mm	B, mm	Width, mm	Angle	Weight, kg
LMB1000	1100	1400	1200	1005	2000	10°	300
LMB1200	1200	1500	1200	1005	2100	10°	310
LMB1300	1300	1650	1200	1005	2200	10°	320
LMB1400	1400	1800	1200	1005	2300	10°	330
LMB1500	1500	1900	1200	1005	2400	10°	340

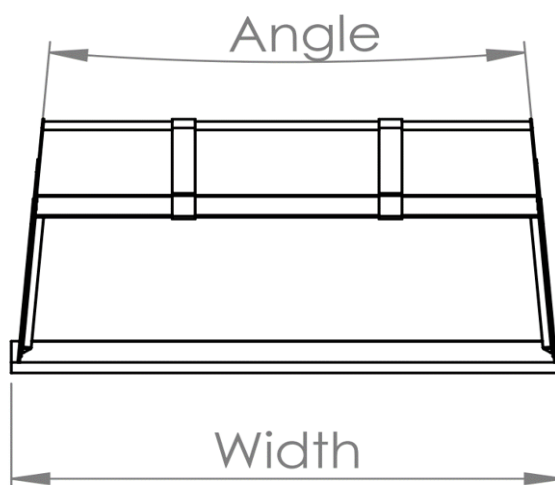
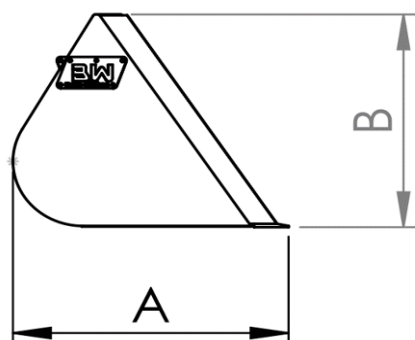

GRAVEL BUCKETS

600-1400l

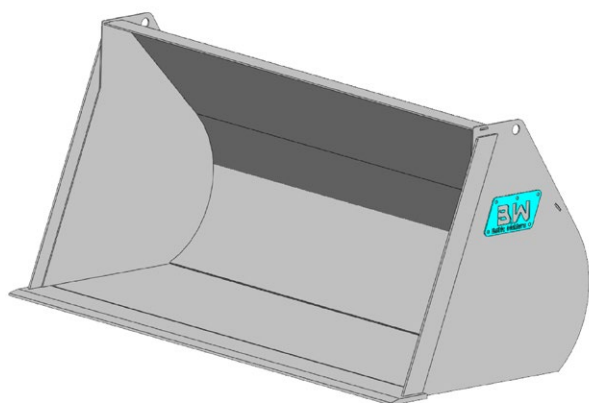

Product	Capacity, l	Capacity with heap, l	A, mm	B, mm	Width, mm	Weight, kg
GB600	600	700	950	870	1300	260
GB700	700	800	950	870	1500	280
GB900	900	1100	950	870	1900	340
GB1000	1000	1200	1100	1040	2000	400
GB1150	1150	1400	1100	1040	2100	430
GB1300	1300	1600	1100	1040	2200	450
GB1400	1400	1700	1100	1040	2300	480

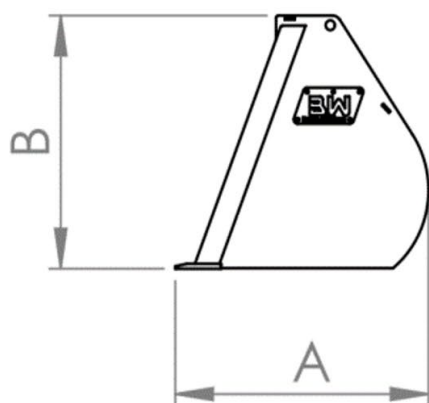

GRAVEL BUCKETS

2000-5000l

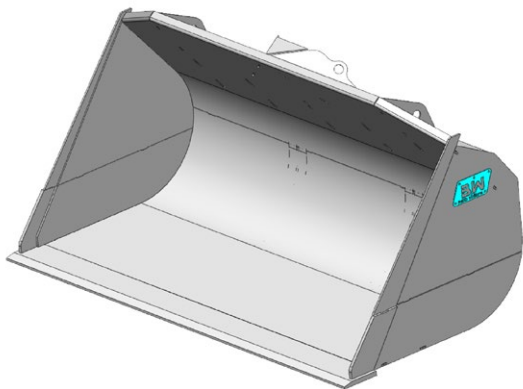

Product	Capacity, l	Capacity with heap, l	A, mm	B, mm	Width, mm	Weight, kg
GB2000	2000	2500	1150	1150	3000	850
GB2500	2500	3000	1300	1300	3000	1000
GB3000	3000	3600	1470	1470	3000	1200
GB3500	3500	4200	1470	1470	3200	1400
GB4000	4000	5000	1600	1600	3200	1600
GB4500	4500	5500	1700	1700	3200	1800
GB5000	5000	6000	1700	1700	3400	2000

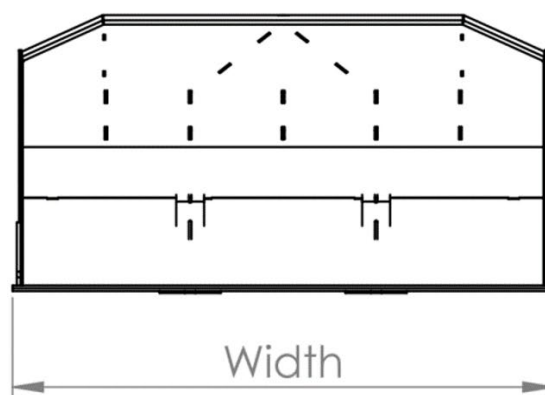
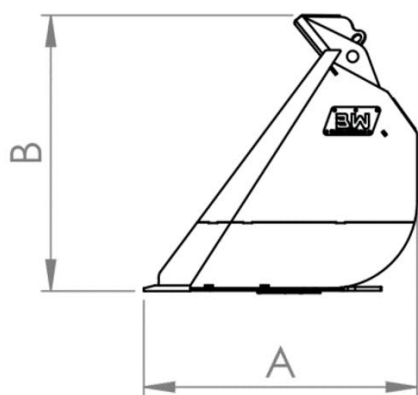

EXCAVATOR BACK BUCKETS

For machines weighing 2-13t

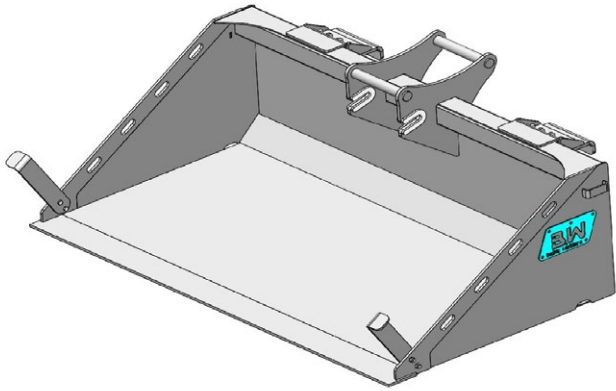

Product	Machine weight, t	Capacity, l	A, mm	B, mm	Width, mm	Weight, kg
EXB200-S30	<2	200	700	475	970	95
EXB400-S40	<3	400	890	550	1480	220
EXB500-S40	<5	500	1020	590	1850	275
EXB550-S40	<5	550	1020	590	2050	295
EXB700-S45	<8	700	1205	680	2150	450
EXB750-S45	<8	750	1205	680	2300	470
EXB800-S45	<8	800	1205	680	2500	500
EXB1000-S60	<13	1000	1205	755	2500	630
EXB1200-S60	<16	1200	1305	855	2600	800

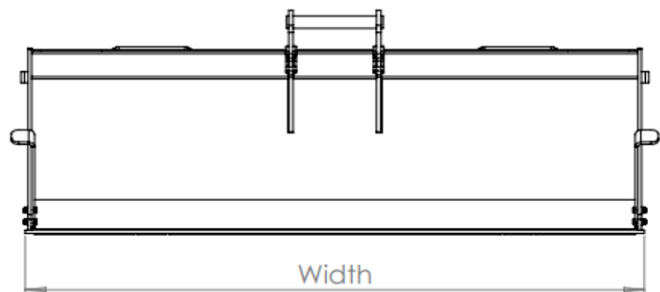
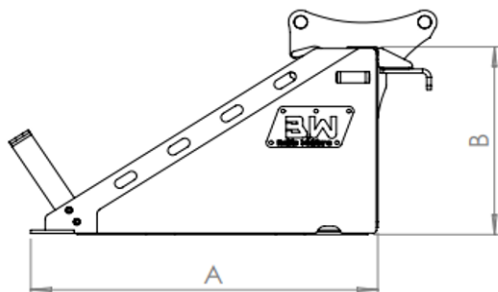

SIDE TIP BUCKETS

800-1000l

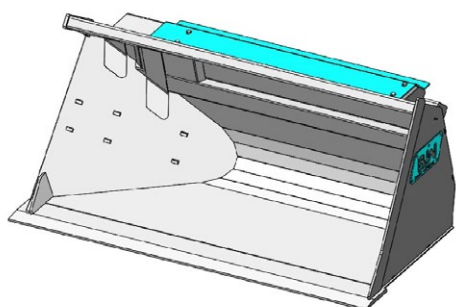

Product	Capacity, l	Capacity with heap, l	A, mm	B, mm	C, mm	Width, mm	Weight, kg
STP800	800	1000	900	902	1055	1800	560
STP1000	1000	1300	900	902	1055	2100	620

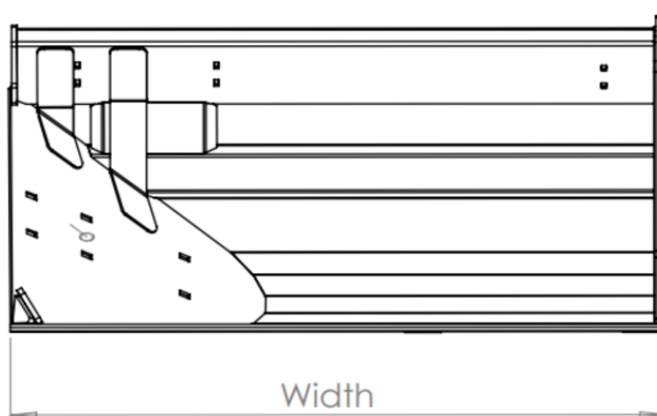
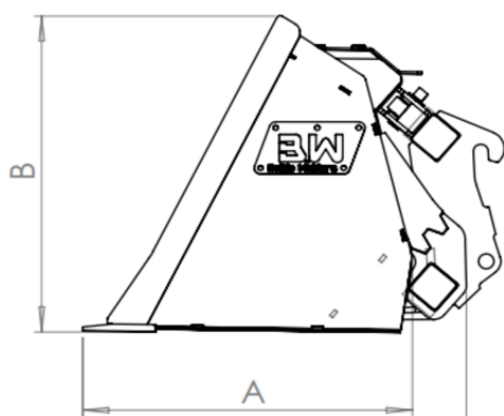

V-LINE BUCKETS

For machines weighing 1-8t

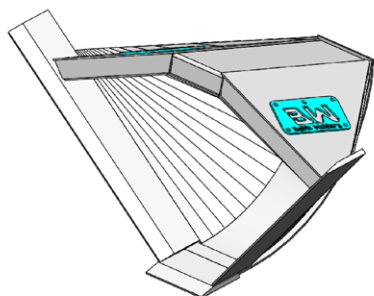

Product	Machine weight, t	Capacity, l	Capacity with heap, l	A, mm	B, mm	C, mm	Width, mm	Weight, kg	Teeth
VB50	<1	50	60	500	500	700	200	40	-
VB50T	<1	50	60	500	500	700	200	45	2
VB100	<2	100	120	550	550	950	200	60	-
VB100T	<2	100	120	550	550	950	200	65	2
VB150	<4	150	170	600	650	1300	200	80	-
VB150T	<4	150	170	600	650	1300	200	85	2
VB200	<6	200	240	660	740	1360	235	100	-
VB200T	<6	200	240	660	740	1360	235	120	2
VB250	<6	250	275	750	800	1500	235	150	-
VB250T	<6	250	275	750	800	1500	235	160	2
VB300	<7	300	330	850	850	1600	235	180	-
VB300T	<7	300	330	850	850	1600	235	190	2
VB350	<8	350	380	950	900	1750	250	270	-
VB350T	<8	350	380	950	900	1750	250	285	2
VB400	<8	400	440	1020	900	2100	320	300	-
VB400T	<8	400	440	1020	900	2100	320	315	2
VB450	<8	450	500	1100	950	2200	320	320	-
VB450T	<8	450	500	1100	950	2200	320	335	2

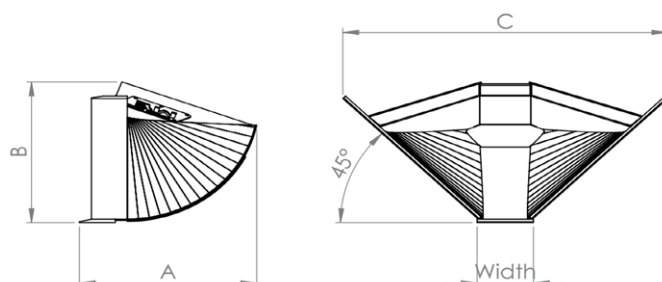

V-LINE BUCKETS

For machines weighing 13-26t

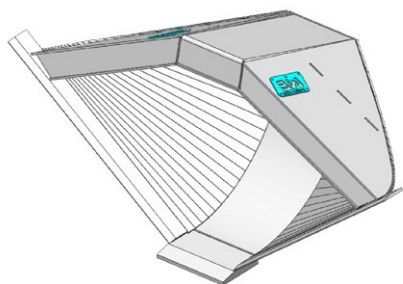

Product	Machine weight, t	Capacity, l	Capacity with heap, l	A, mm	B, mm	C, mm	Width, mm	Weight, kg	Teeth
VB500	<13	500	600	850	850	2400	400	380	-
VB500T	<13	500	600	850	850	2400	400	400	2
VB600	<16	600	750	950	950	2800	400	550	-
VB600T	<16	600	750	950	950	2800	400	575	2
VB800	<20	800	1000	1200	1200	2850	500	650	-
VB800T	<20	800	1000	1200	1200	2850	500	690	3
VB1000	<26	1000	1200	1200	1200	3300	500	740	-
VB1000T	<26	1000	1200	1200	1200	3300	500	780	3

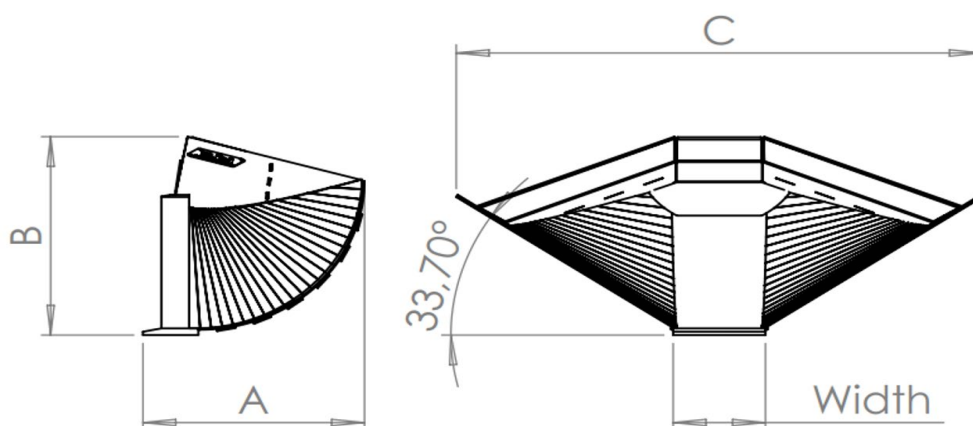

V-LINE BUCKETS

For machines weighing 16-26t

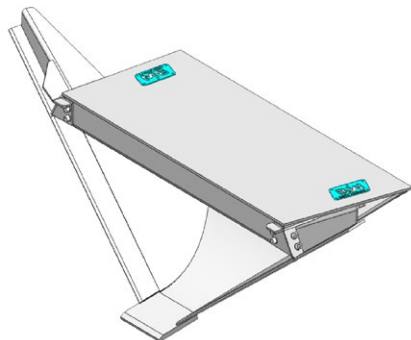

Product	Machine weight, t	Capacity, l	Capacity with heap, l	A, mm	B, mm	C, mm	D, mm	Width, mm	Weight, kg	Teeth
VB600R	<16	600	750	950	950	3000	2000	400	550	-
VB600RT	<16	600	750	950	950	3000	2000	400	575	2
VB850R	<22	850	1050	1400	900	3500	2500	400	900	-
VB850RT	<22	850	1050	1400	900	3500	2500	400	950	2
VB1000R	<26	1000	1200	1400	1000	3500	2500	500	1100	-
VB1000RT	<26	1000	1200	1400	1000	3500	2500	500	1150	3

Available with removable blades

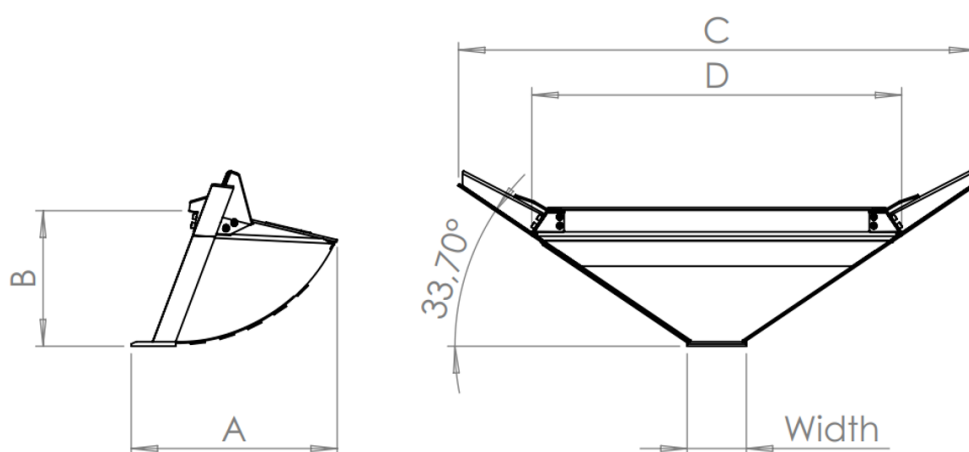

V-LINE HYDRAULIC BUCKETS

For machines weighing 16-20t

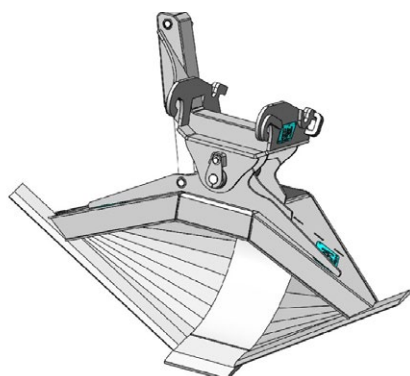

Product	Machine weight, t	Capacity, l	Capacity with heap, l	A, mm	B, mm	C, mm	Width, mm	Weight, kg	Teeth
VB600VH	<16	600	750	950	950	2500	400	690	-
VB600VHT	<16	600	750	950	950	2500	400	855	2
VB800VH	<20	800	1000	1200	1200	2850	500	910	-
VB800VHT	<20	800	1000	1200	1200	2850	500	950	3

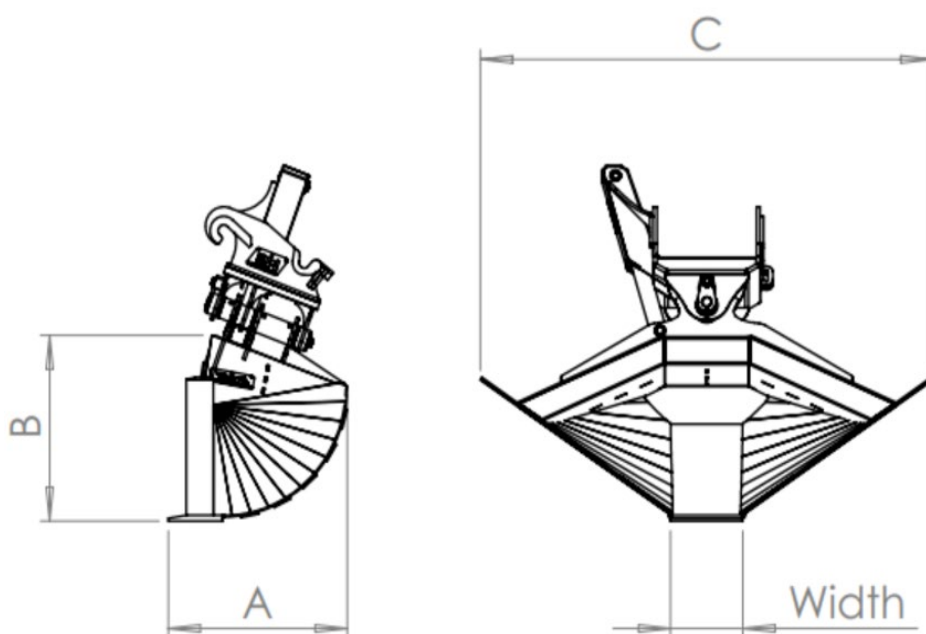

STATIC QUICK S-TYPE COUPLINGS

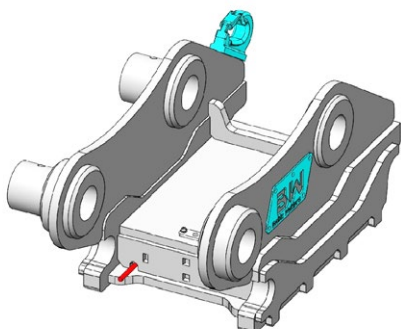

Product	Coupler	Locking system	Reccomended machine weight, t	Extras	Weight, kg
SQ_S30-150M	S30-150	Mechanical	0,5-2	-	20
SQ_S30-180M	S30-180	Mechanical	0,5-2	-	20
SQ_S40M	S40	Mechanical	2-5	-	40
SQ_S40H	S40	Hydraulic	2-5	-	45
SQ_S45M	S45	Mechanical	5-12	-	60
SQ_S45H	S45	Hydraulic	5-12	-	65
SQ_S50M	S50	Mechanical	5-13	-	60
SQ_S50H	S50	Hydraulic	5-13	-	65
SQ_S60M	S60	Mechanical	12-18	Hook 3t	160
SQ_S60H	S60	Hydraulic	12-18	Hook 3t	160
SQ_S70H	S70	Hydraulic	17-25	Hook 3t	235
SQ_S80H	S80	Hydraulic	25-40	Hook 5t	420
SQ_S80HD	S80	Hydraulic	40-50t	Hook 5t	530

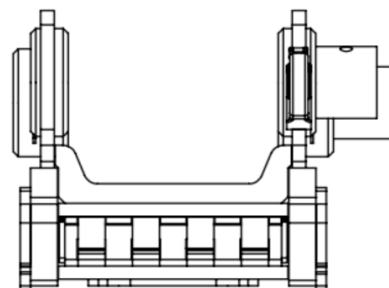
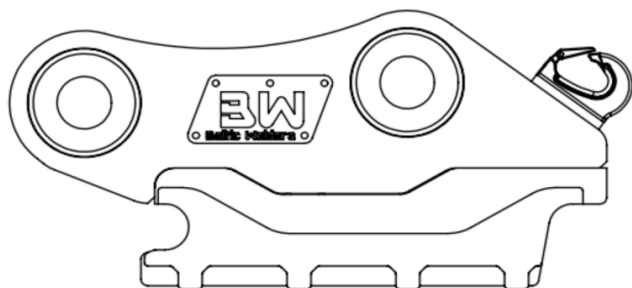

STATIC QUICK COUPLINGS

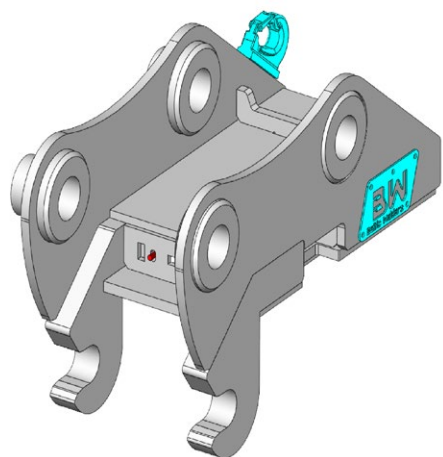

Product	Coupler	Locking system	Reccomended machine weight, t	Extras	Weight, kg
SQ_NTP10H	NTP10	Hydraulic	10-16	Hook 3t	180
SQ_NTP10M	NTP10	Mechanical	10-16	Hook 3t	180
SQ_NTP10H	NTP10	Hydraulic	16-24	Hook 3t	230
SQ_NTP10M	NTP10	Mechanical	16-24	Hook 3t	230

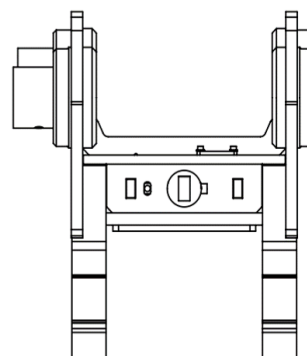
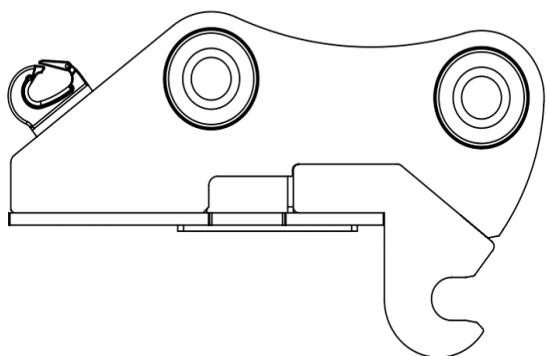

TILTING QUICK COUPLINGS S-TYPE

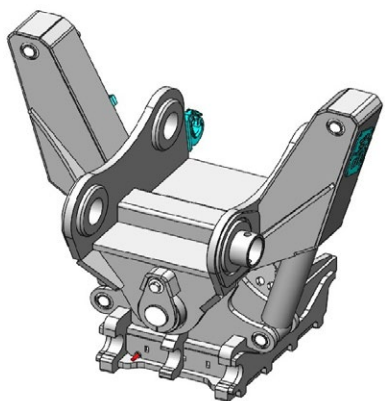

Product	Coupler	Locking system	Reccomended machine weight, t	Extras	Weight, kg	Cylinders
DQ_NTP10	S60	Hydraulic	12-16	-	440	1 (VH)
DQ_S60H-1	S60	Hydraulic	12-16	-	420	1 (VH)
DQ_S60H-2	S60	Hydraulic	12-18	-	450	2 (VH)
DQ_S70H	S70	Hydraulic	17-25	Hook 3t	550	2 (VH)
DQ_S80H	S80	Hydraulic	25-40	Hook 5t	750	2 (VH)
DQ_Miller65H	Miller65	Hydraulic	12-18	-	420	1 (VH)
DQ_Miller80H	Miller80	Hydraulic	17-25	Hook 3t	550	2 (VH)

Tilting angle is 45° + 45°
VH - Vertical hidden cylinders

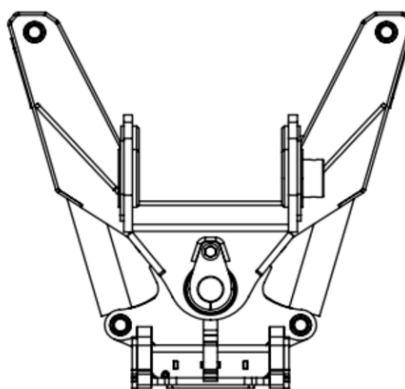
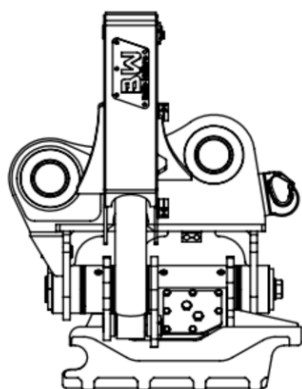

S-TYPE COUPLINGS

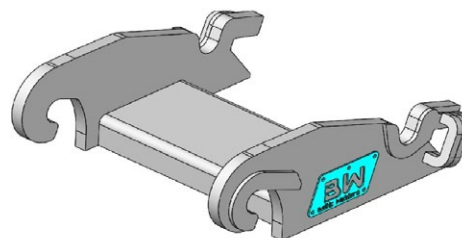
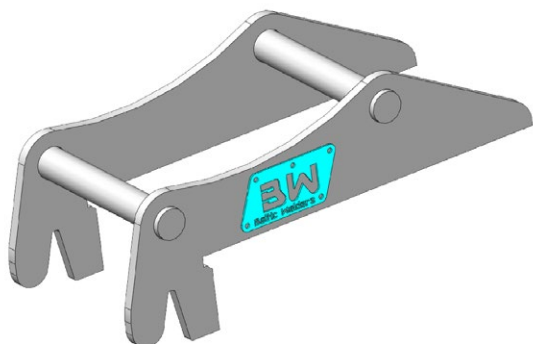

Product	A, mm	B, mm	D, mm	Weight, kg
S30-150	150	200	30	8
S30-180	180	230	30	9
S40	200	300	40	18
S45	290	430	45	27
S50	270	430	50	28
S60	340	480	60	60
S70	450	600	70	85
S80	590	670	80	150
S90	750	750	90	225
S100	750	900	100	305
S120	925	870	120	450
JCB4CX	170	343	45	20
Miller65	255	390	65	65
Miller80	305	450	80	80
CW10	320	300	50	25
CW20S	430	475	60	100
CW30	550	475	60	180
CW40	550	475	60	260

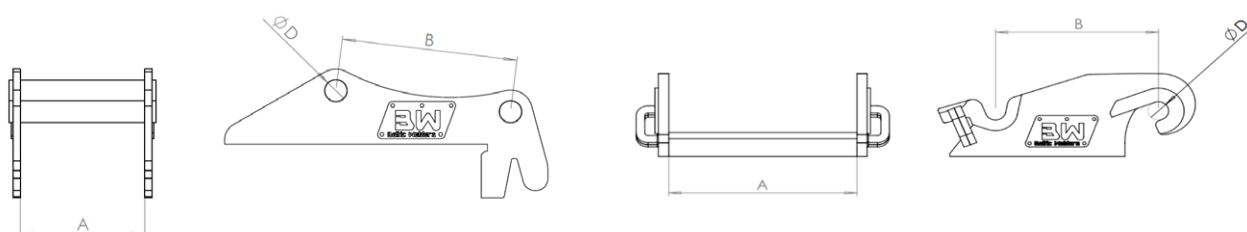

NTP TYPE COUPLINGS

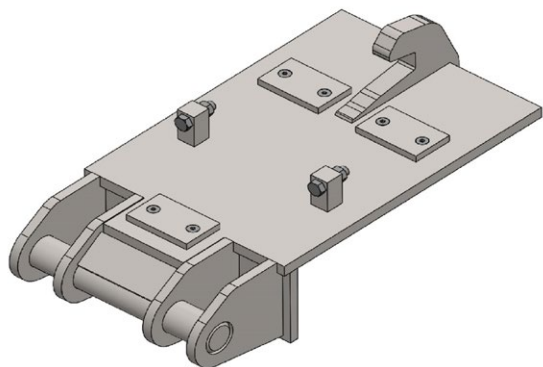

Product	A, mm	B, mm	D, mm	Weight, kg
NTP10	225	445	70	105
NTP20	305	485	80	130
NTP30	350	525	80	150
NTP40	340	632	100	375

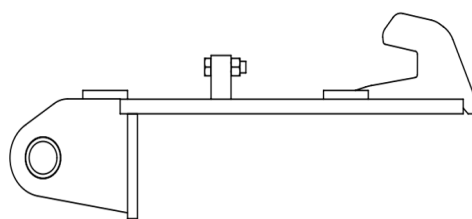
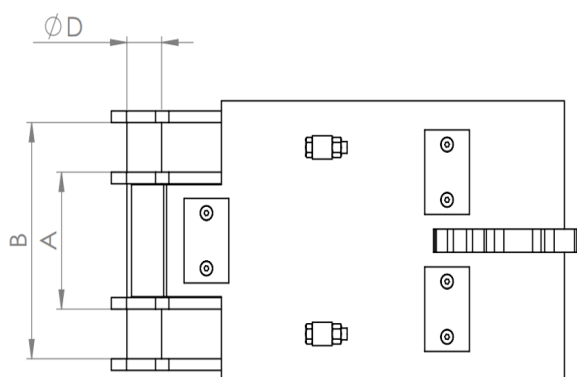

COUPLINGS FOR LOADERS

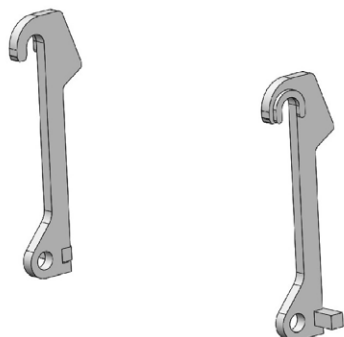

Product	A, mm	B, mm	C, mm
Vovlo30	860	331	40/40
Volvo120	965	646	60/50
Volvo150	1010	821	80/75
Kramer5035	305	265	30/30
Kramer8115	865	300	40/40
Kramer1150	865	300	40/40
Liebherr 506	860	331	40/40
CAT444	540	553	60/50
Dieci	620	532	60/40
Komatsu WB97	1140	598	50/45
JCB Qfit	990	631	60/35
Kunta500	865	500	60/50
Merlo	1145	412	60/35
Manitou	760	395	80/35

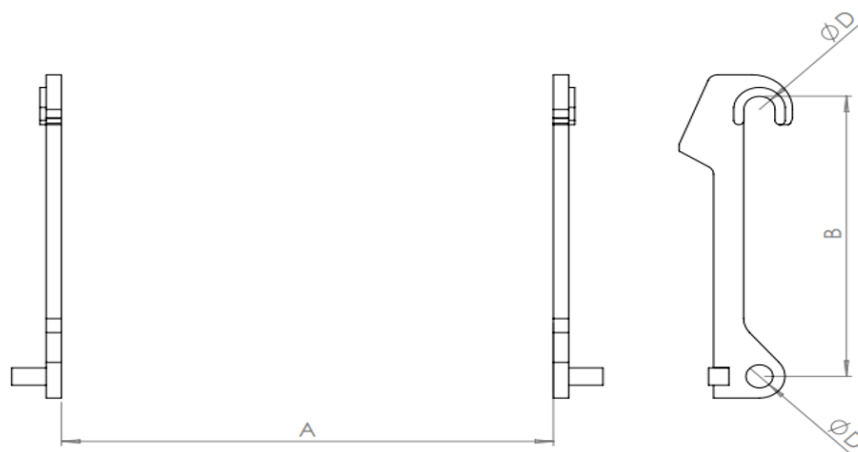

FRONTAL QUICK COUPLERS FOR LOADERS

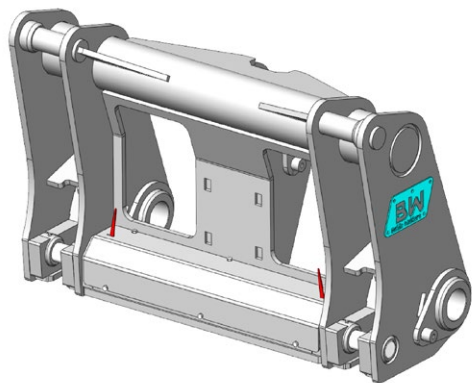

Product	Coupler	Locking system	Weight, kg
FQM_V120	Volvo120	Mechanical	450
FQH_V120	Volvo120	Hydraulic	450
FQM_V150	Volvo150	Mechanical	650
FQH_V150	Volvo150	Hydraulic	650

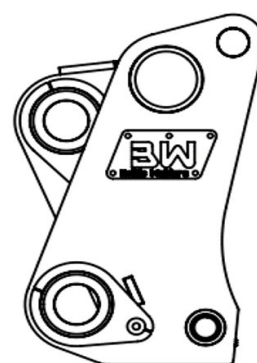
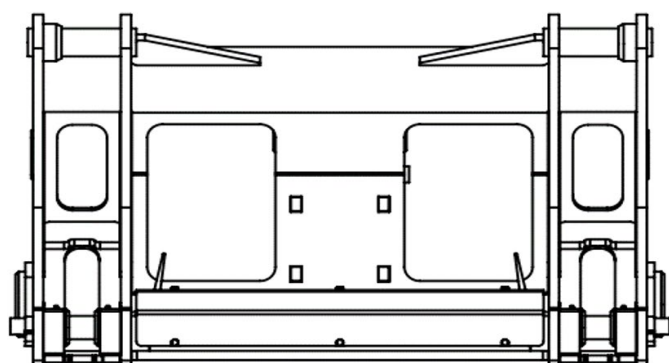

FRONTAL QUICK COUPLERS

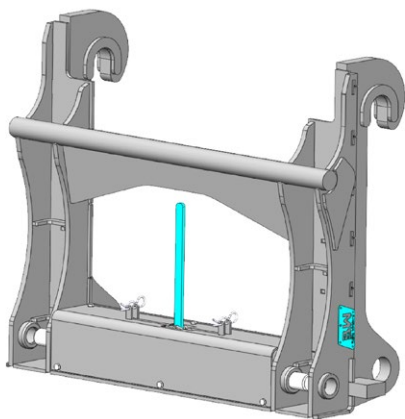

Product	Coupler	Locking system	Weight, kg
V150-V120	Volvo120	Mechanical	250
V150-V120	Volvo120	Hydraulic	250
JCB_Qfit_Manitou		Mechanical	120
V120-Claas_Scorpion		Mechanical	170
H102-V120	Hidromek 102S	Mechanical	200
H102-V120H	Hidromek 102S	Hydraulic	200
JCB-V120		Mechanical	200
JCB-V120H		Hydraulic	200
JCB_Qfit_Manitou		Mechanical	120

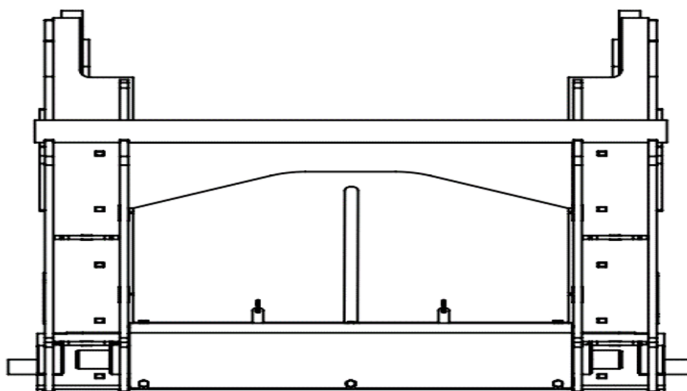
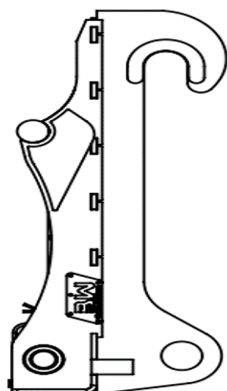

ADAPTERS FOR HAMMERS

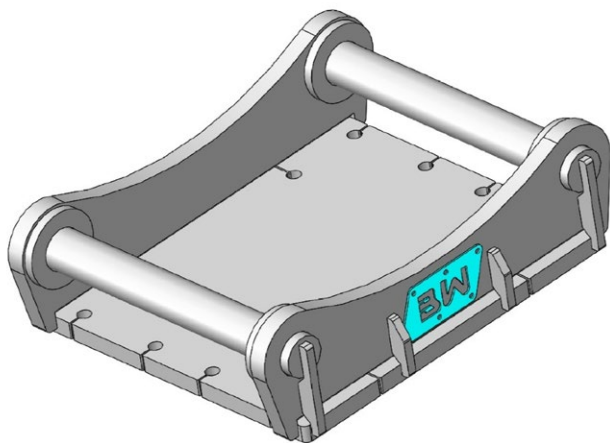

Product	A, mm	B, mm	Coupling	Weight, kg
HP_S70	570	640	S70	175
HP_S80	700	700	S80	300

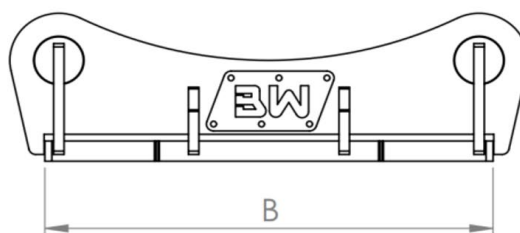
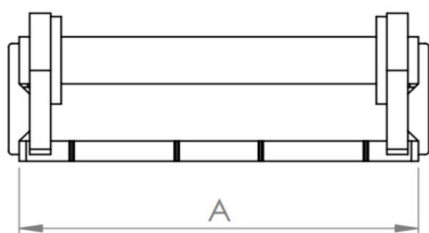

ADAPTERS FOR HAMMERS

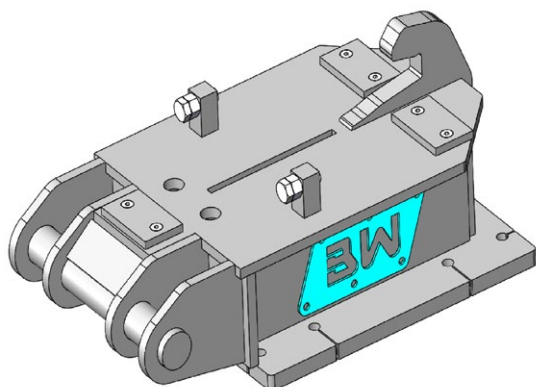

Product	A, mm	B, mm	D, mm	Coupling	Weight, kg
HP_570x640_NTP10	225	405	70	NTP10	245

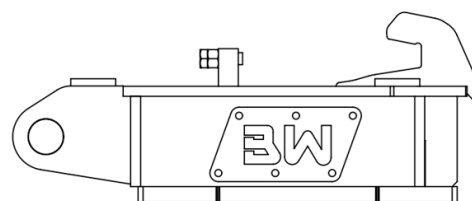
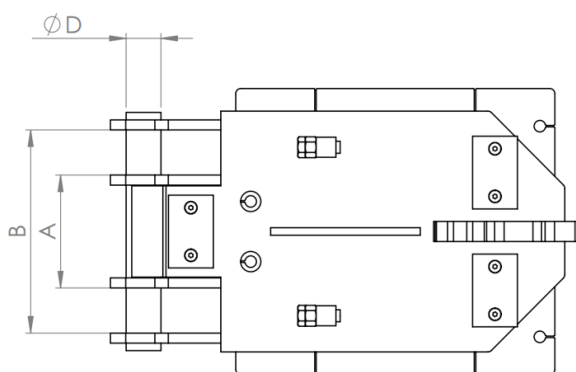

ADAPTERS

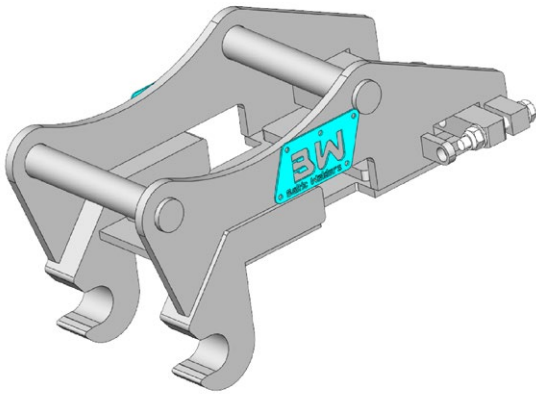

Product	Coupling	Coupler	Weight, kg
ADA_S60_WB97	S60	WB97	100
ADA_S60_NTP10	S60	NTP10	160
ADA_S70_NTP10	S70	NTP10	200
ADA_S70-S80	S70	S80	300
ADA_S80-S70	S80	S70	300
ADA_CW30_NTP10	CW30	NTP10	280
ADA_CW40_S60	CW40	S60	225
ADA_NTP10-S60	NTP10	S60	230
ADA_NTP10-S70	NTP10	S70	310
ADA_HI470	Eccentric	Hitachi 470	600

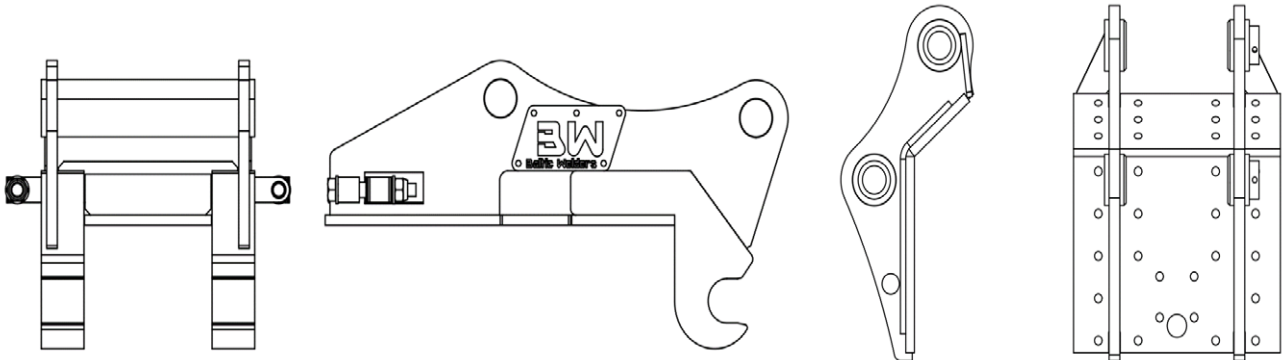

ADAPTERS FOR EQUIPMENT

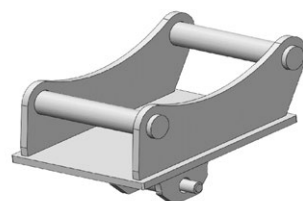
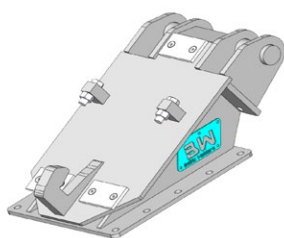
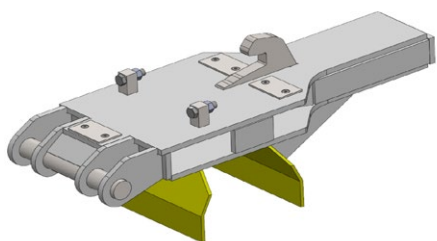

Product

Adapters for drills

Adapters for energy wood grapplers

Adapters for log grapples

Adapters for mowers

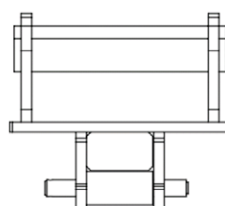
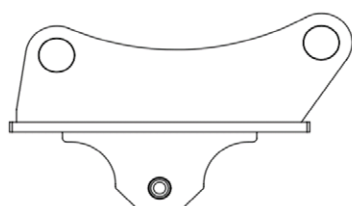
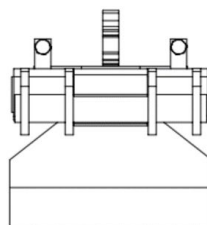
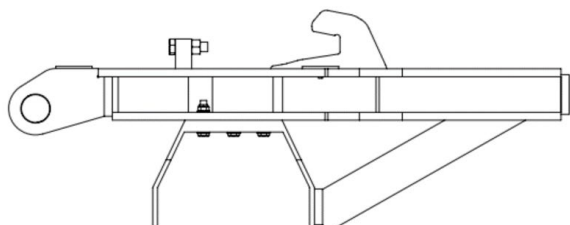
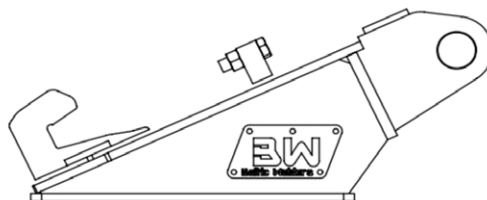
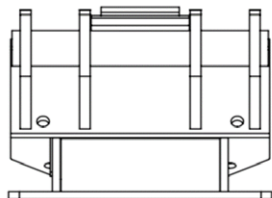

DIGGING BUCKET THUMB

For machines 3-24t

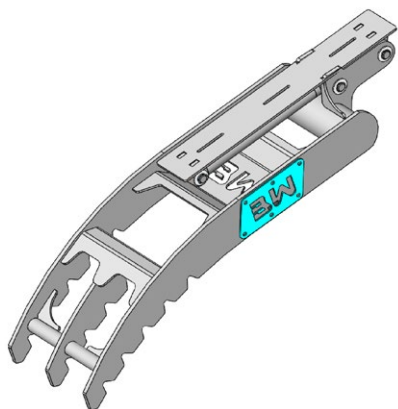

Product	Machine weight, t	A, mm	Cylinder, mm	Width, mm	Weight, kg
BT1850	<22	1850	80.50.400	500	250
BT1600	<15	1600	70.40.1000	470	160
BT1220A	<8	1220	63.40.360	400	115
BT900A	<6	900	50.30.300	300	80
BT600A	<6	600	50.30.300	300	65

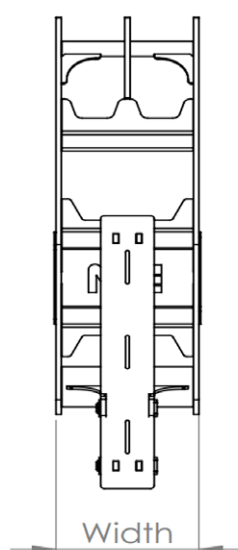
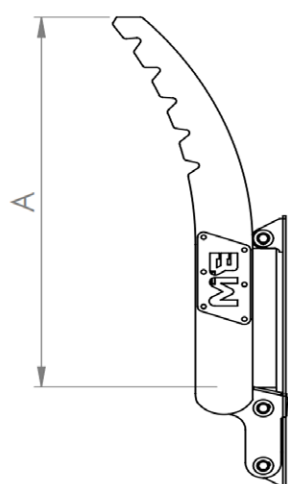

HOOKS

For machines 2-45t

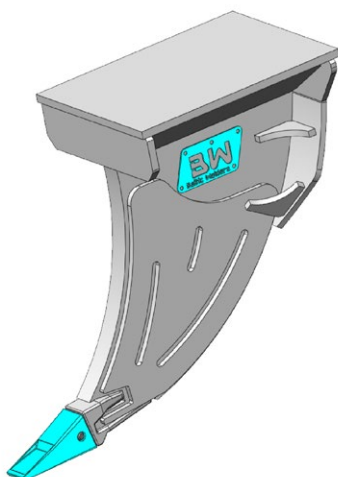

Product	Machine weight, t	A, mm	B, mm	C, mm	Adapter	Weight, kg
HO1_2t	>2t	440	520	50	J200	40
HO2_5t	>5t	680	760	60	J250	90
HO3_10t	>10t	780	980	64	J250	135
HO4_16t	>16t	1000	810	92	J300	310
HO5_20t	>20t	1100	970	92	J350	350
HO6_24t	>24t	1190	1065	100	J450	400
HO7_28t	>28t	1200	1200	100	J550	520
HO8_45t	>45t	1200	1300	160	J600	1000

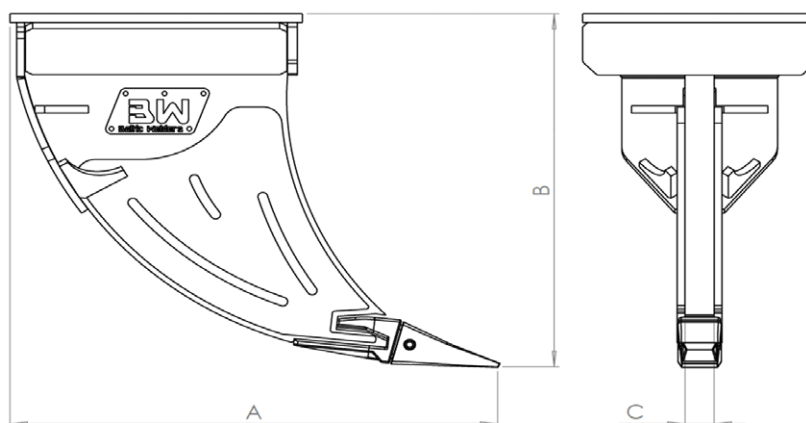

STUB CRUSHERS

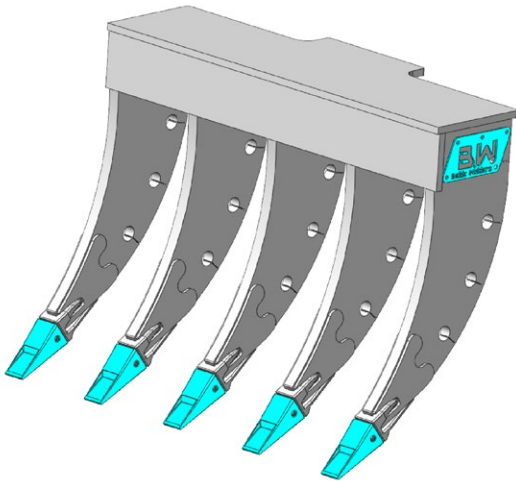

Product	A, mm	B, mm	C, mm	Teeth	No of teeth	Weight, kg
SC1000-4W	1000	750	30	-	4	300
SC1140-4	1140	1160	40	J300 adapters	4	660
SC1140-4W	1140	1070	40	-	4	620
SC1140-6	1140	1160	40	J300 adapters	6	670
SC1140-6W	1140	1070	40	-	6	610
SC1500-5	1500	1160	40	J300 adapters	5	820
SC1500-5W	1500	1070	40	-	5	770
SC1500-8	1500	1160	40	J300 adapters	8	1125
SC1500-8W	1500	1070 <td 40	-	8	1025	
SC1920-6	1920	1160	40	J300 adapters	6	1000
SC1920-6W	1920	1070	40	-	6	940
SC2280-7	2280	1160	40	J300 adapters	7	1150
SC2280-7W	2280	1070	40	-	7	1080

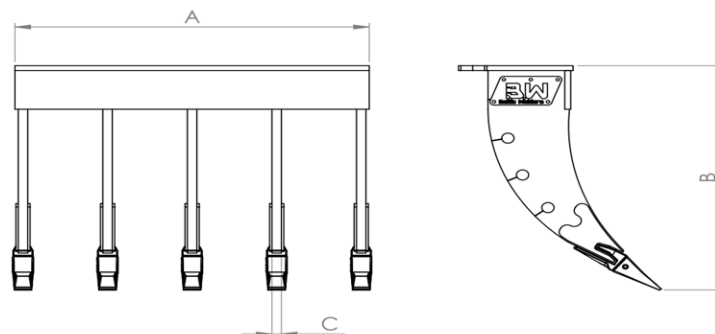

STUB CRUSHERS WITH GRAPPLE

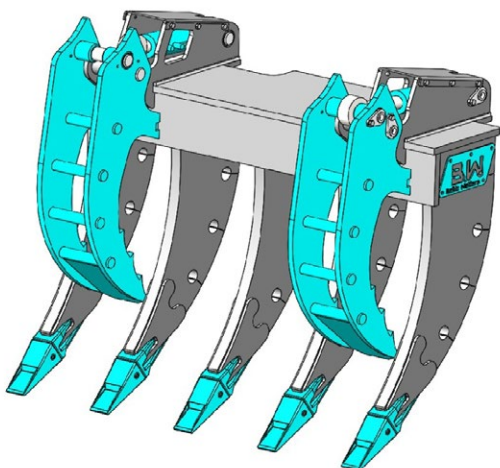

Product	A, mm	B, mm	C, mm	D, mm	E, mm	Teeth	No of teeth	Weight, kg
SC1500-5GR	1500	1160	40	1690	220	J300 adapters	5	1060
SC1920-6GR	1920	1160	40	1690	220	J300 adapters	6	1240
SC2280-7GR	2280	1160	40	1690	220	J300 adapters	7	1390

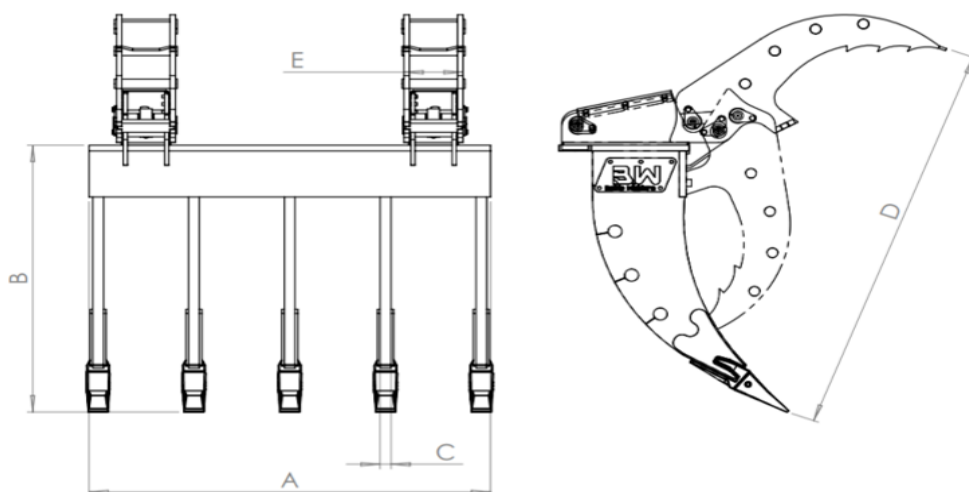

RAKES

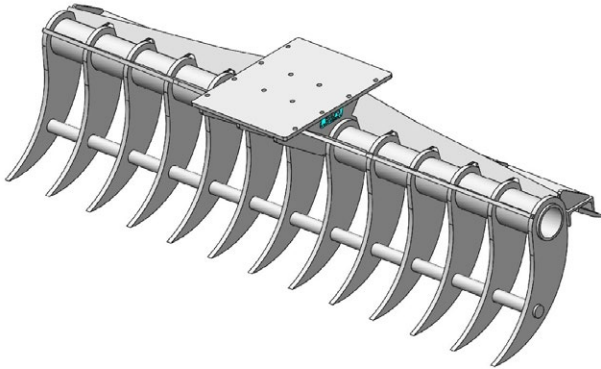

Product	A, mm	B, mm	C, mm	Material	No of teeth	Version	Weight, kg
RA800	800	650	10	Hardox 450	9		45
RA120-30	1200	500	10	Hardox 450	12		65
RA1000	1500	500	15	Hardox 450	9		150
RA1200	2000	500	15	Hardox 450	12		210
RA1700	1700	500	20	Hardox450	15		400
RA1800	1800	500	20	Hardox450	10		300
RA1800A	1800	500	20	Hardox450	10	Back blade	360
RA2000	2000	500	20	Hardox450	10		400
RA2000A	2000	500	20	Hardox450	10	Back blade	460
RA2500	2500	500	20	Hardox450	14		480
RA2500A	2500	500	20	Hardox450	14	Back blade	540
RA3000	3000	1500	30	Hardox450	9		2150

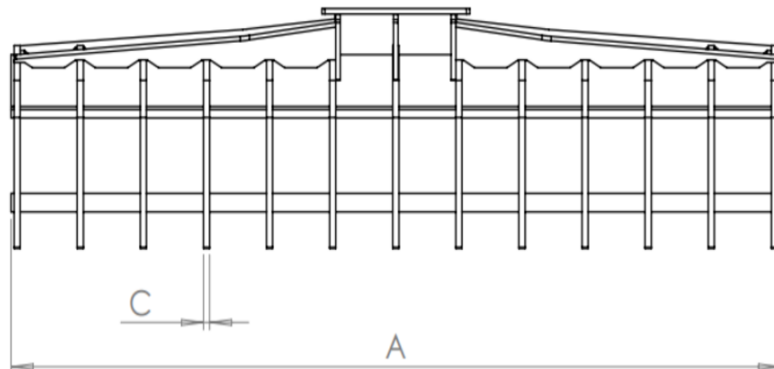
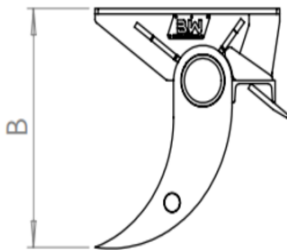

HYDRAULIC FOREST RAKES

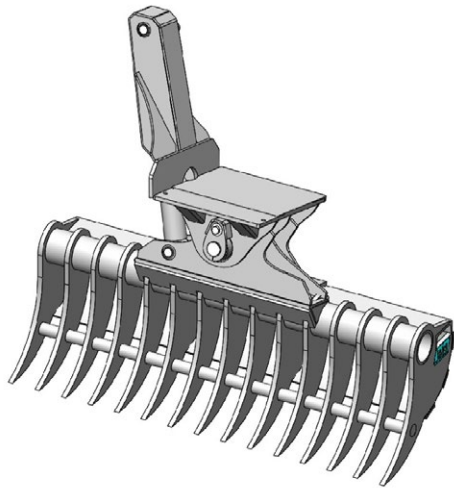

Product	A, mm	B, mm	C, mm	D, mm	Material	No of teeth	Weight, kg
RA1700C	1700	500	20	990	Hardox450	15	660
RA2500C	2500	500	20	990	Hardox450	14	750

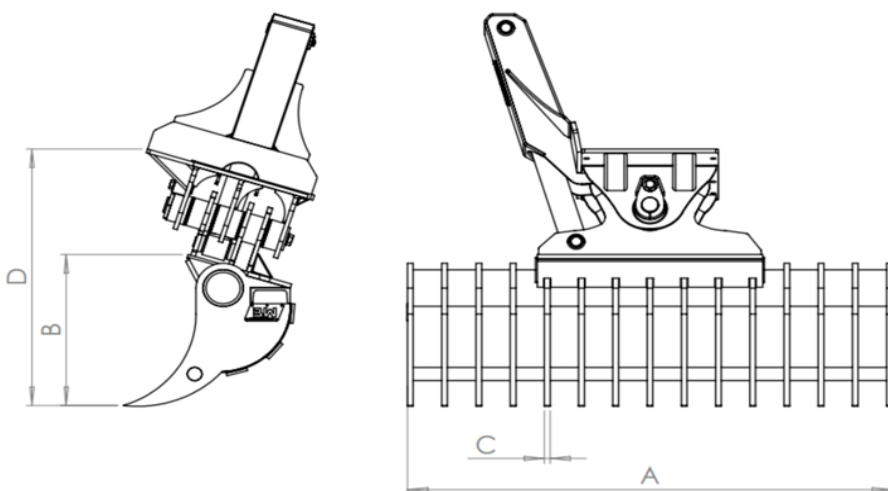

STUB FLIPPER

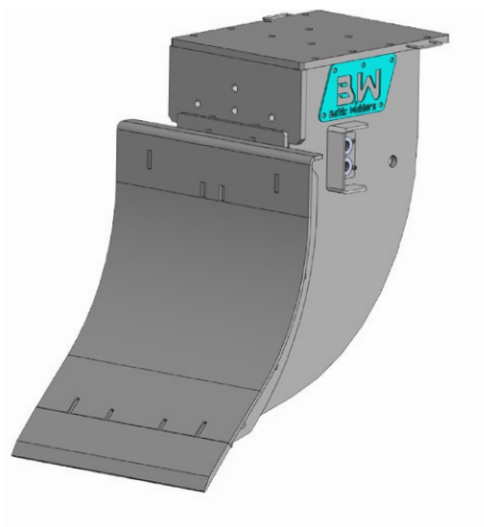

Product	Machine weight, t	A, mm	B, mm	C, mm	Movement	Weight, kg
SF1000	13-21	1000	1068	700	Hydraulic	430

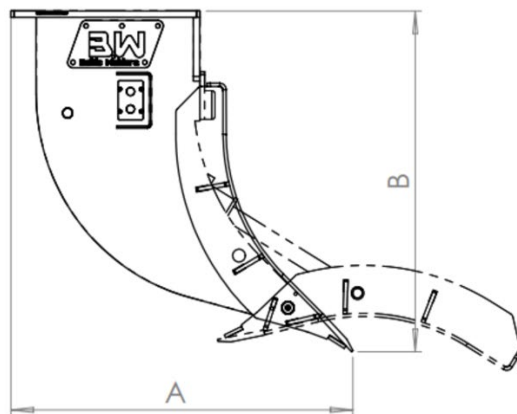
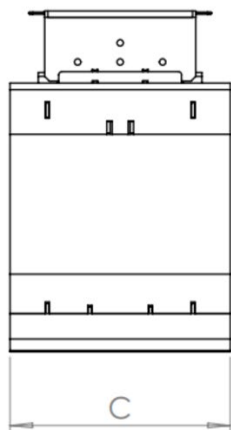

PALLET FORKS

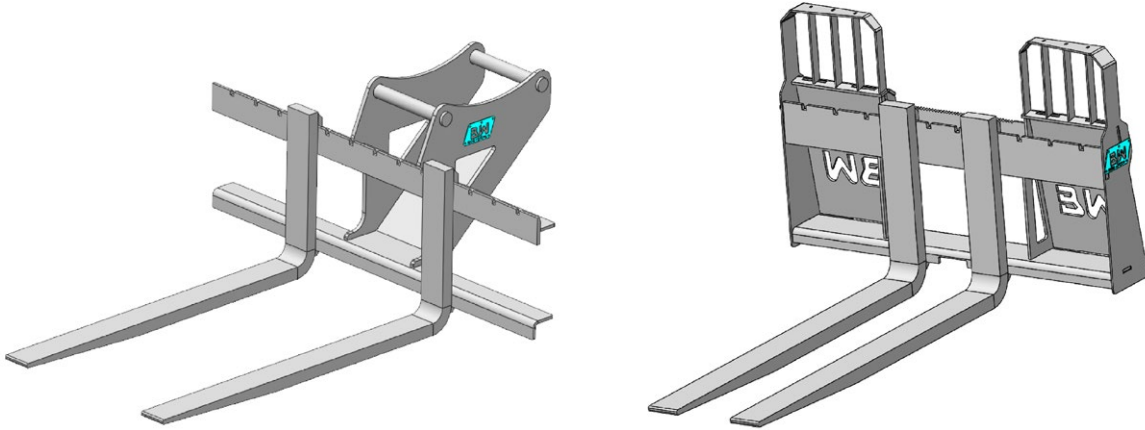

Product	Lifting capacity, t	A, mm	B, mm	C, mm	Fork type	Type	Weight, kg
PF-FEM2_BC	< 2,5	1200	750	1140	FEM2	Mechanical	175
PF-FEM2A	<2,5	1200	650	1500	FEM2A	Mechanical	200
PF-FEM2A	<2,5	1500	650	1500	FEM2A	Mechanical	200
PF-FEM2B	<2,5	1200	800	1500	FEM2B	Mechanical	230
PF-FEM2B	<2,5	1500	800	1500	FEM2B	Mechanical	230
PF-FEM3A	< 5t	1200	800	1500	FEM3A	Mechanical	360
PF-FEM3B	<5t	1500	800	1500	FEM3B	Mechanical	460
PF-FEM4A	< 8t	1500	1000	1500	FEM4A	Mechanical	600
PF-FEM4A	<8t	2400	1000	2200	FEM4A	Mechanical	700

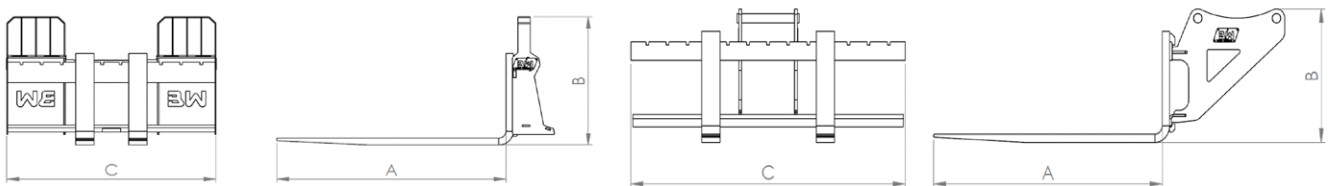

GRADING BARS

For machines 8-22t

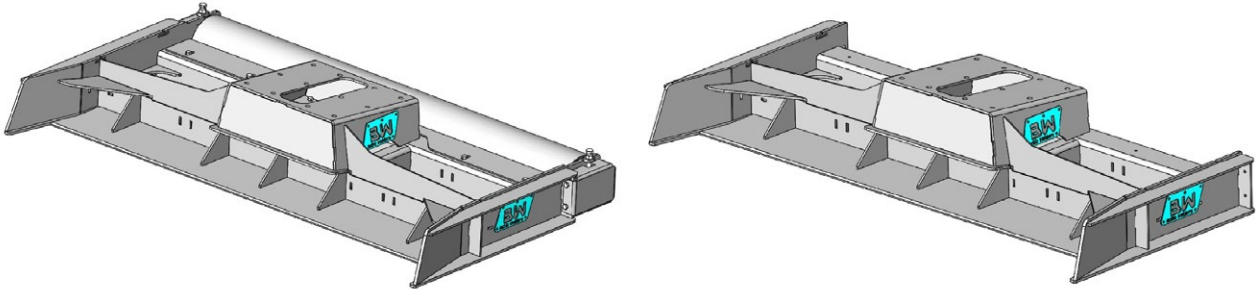

Product	Machine weight, t	A, mm	B, mm	C, mm	Width, mm	Weight, kg	Roller
GBE1600	<8	1100	300	400	1600	200	Ø219
GBE1600W	<8	1100	300	400	1600	175	NA
GBE2000	<12	1100	300	400	2000	250	Ø219
GBE2000W	<12	1100	300	400	2000	225	NA
GBE2500	<16	1250	325	500	2500	450	Ø245
GBE2500W	<16	1250	325	500	2500	420	NA
GBE2500A	<16	1750	325	1000	2500	500	Ø245
GBE3000	<22	1250	325	500	3000	550	Ø245
GBE3000W	<22	1250	325	500	3000	500	NA

Available also without roller

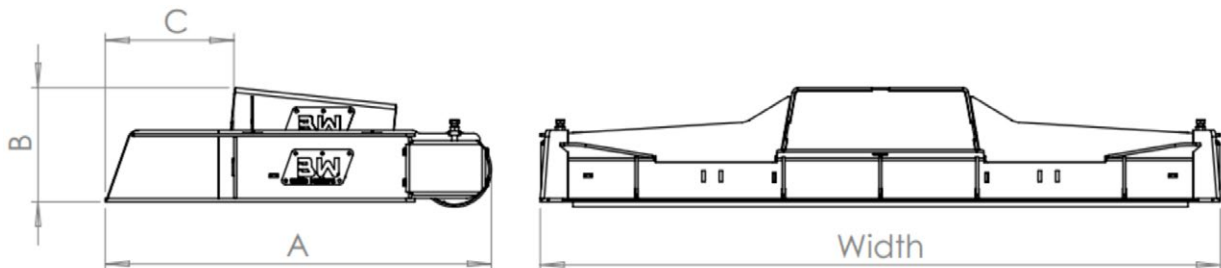

GRADING FRAME

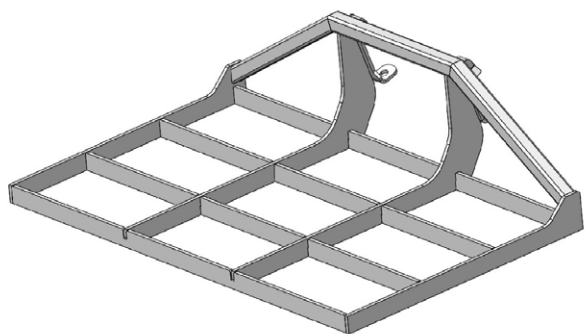

Product	Machine weight, t	A, mm	B, mm	C, mm	Width, mm	Weight, kg
TR1500	<3	950	60	12	1500	75
TR2300	<5	1410	80	20	2300	275

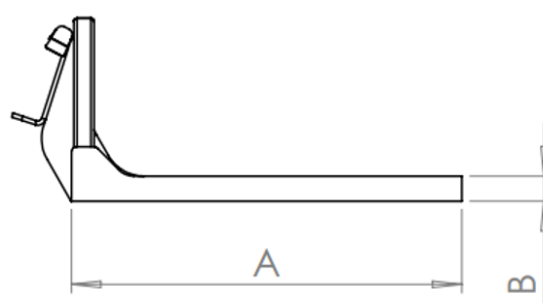
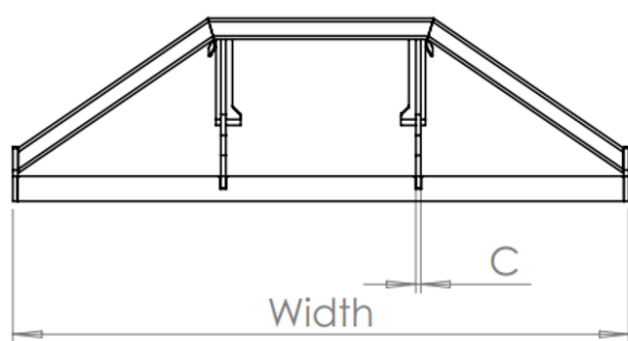

ASFALT CUTTERS

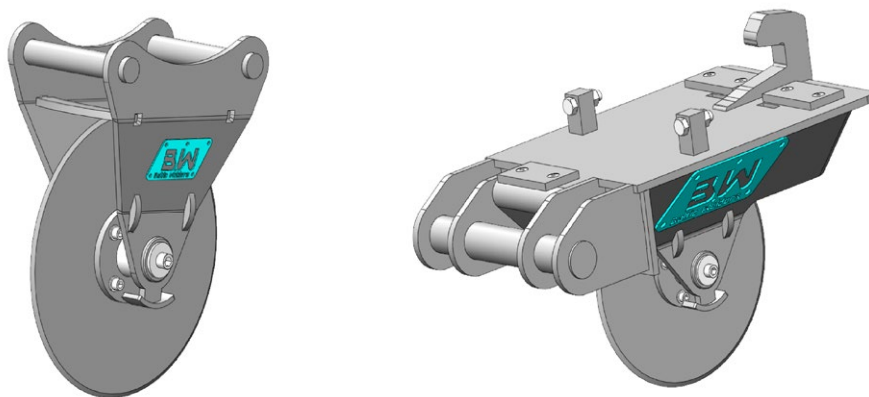

Product	A, mm	B, mm	C, mm	D, mm	Coupling	Weight, kg
AC_S40_450	573	390	150	450	S40	40
AC_S45_450	571	520	150	450	S45	50
AC_S50_450	585	520	150	450	S50	60
AC_S60_450	599	580	150	450	S60	76
AC_S70_450	619	720	150	450	S70	130
AC_NTP10_450	629	882	150	450	NTP10	140

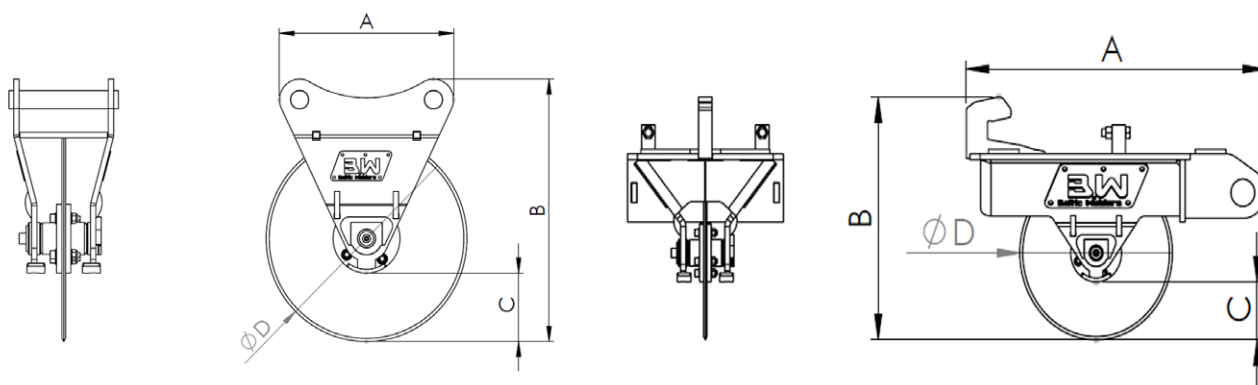

LIFTING BOOMS

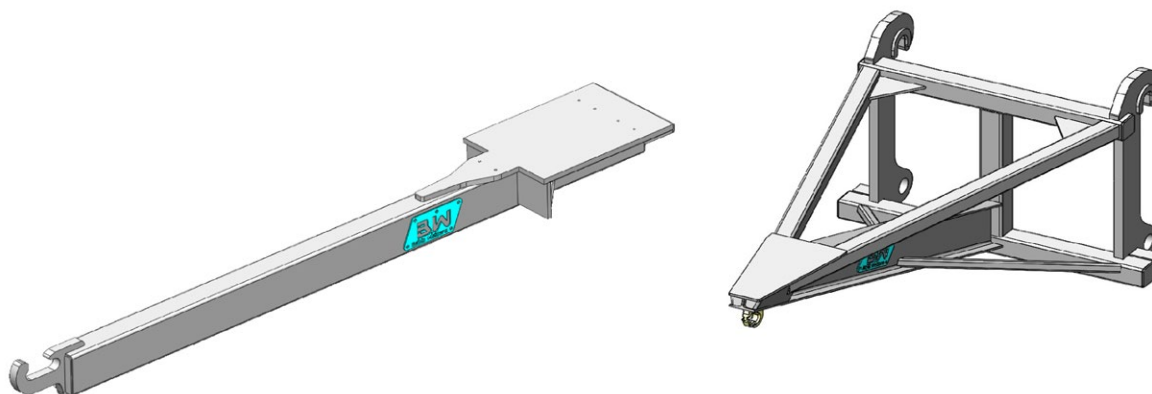

Product	Lifting capacity, t	A, mm	B, mm		Weight, kg
LB2000	<3,0	2000	480		250
LB2000R	<2,0	2000	480	Rotating hook	250
LB2000-V150	<2,0	2000	1350	Volvo LH150	300
LB2500	<2,5	2500	480		275
LB3000	<2,0	3000	480		300

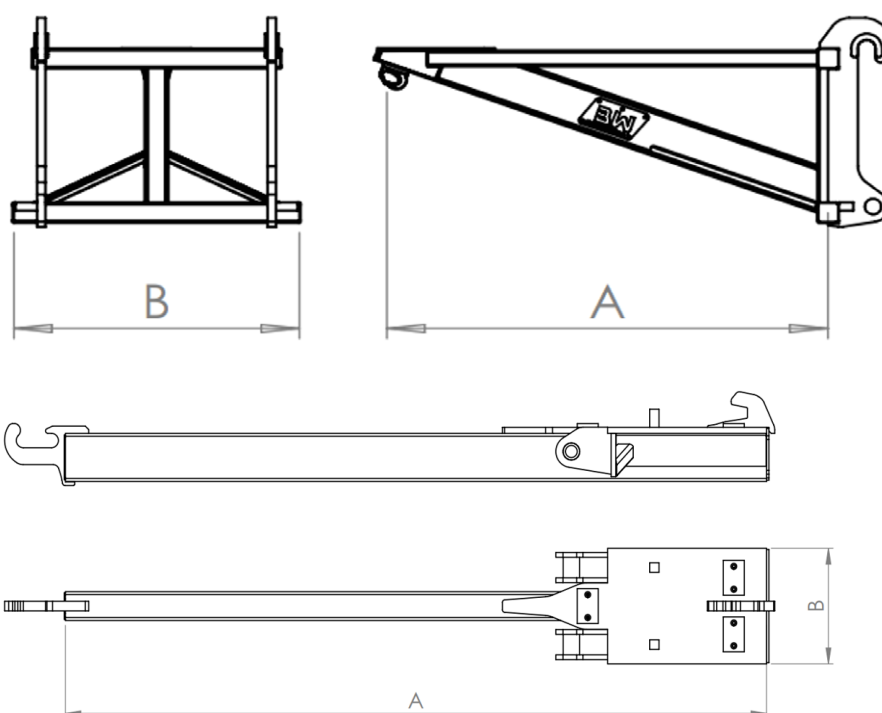

FRONT GUARDS

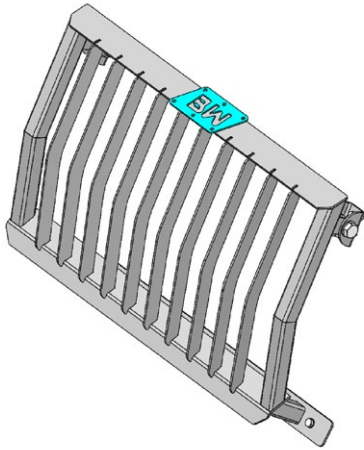

Product	A, mm	B, mm	Extra	Weight, kg
FG-Hitachi	950	530	Tilting frame	25
FG-Hitachi-Full	950			60
FG-Hyundai	950	530	Tilting frame	25
FG-Hyundai-Full	950			60
FG-Kobelco	950	530	Tilting frame	25
FG-Kobelco-Full	950			60
FG-Liebherr	950	530	Tilting frame	25
FG-Liebherr-Full	950			60

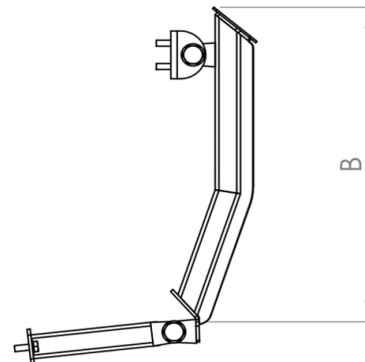
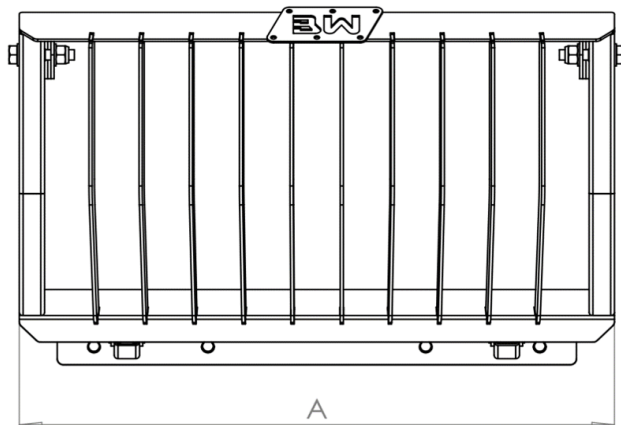

ROOF GUARDS

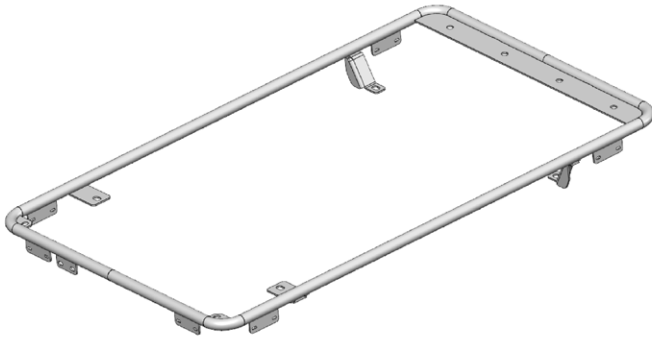

Product	A, mm	B, mm	Weight, kg
RF-Hitachi	1000	1860	65
RF-Hitachi-L	1000	1860	25
RF-Hyundai	1000	1900	65
RF-Hyundai-L	1000	1900	25
RF-Kobelco	1000	1900	65
RF-Kobelco-L	1000	1900	25
RF-Liebherr	1000	1800	75
RF-Liebherr-L	1000	1800	25

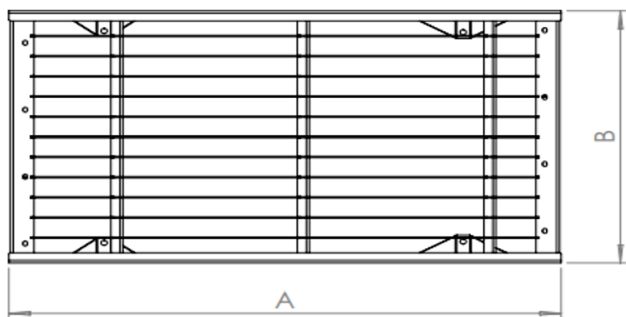

V-PLOUGHS

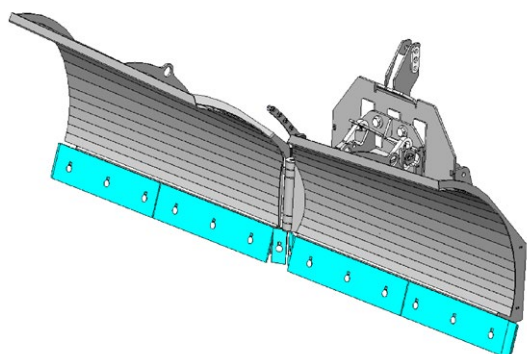

Product	A, mm	B, mm	C, mm	D, mm	Turning angle, °	Positive attack "P" angle, °	Weight, kg
VP1800	1800	750	640	1300	35+35	0	300
VP2000	2000	750	640	1600	35+35	0	350
VP2300	2300	780	640	1900	35+35	0	430
VP2500	2500	870	740	2000	40+40	15	640
VP2700	2700	870	740	2100	40+40	15	670
VP2850	2850	870	740	2200	40+40	15	690
VP3250	3250	1000	840	2500	40+40	15	770
VP3700	3700	1110	970	2900	40+40	15	890
VP4000	4000	1110	970	3100	40+40	15	940

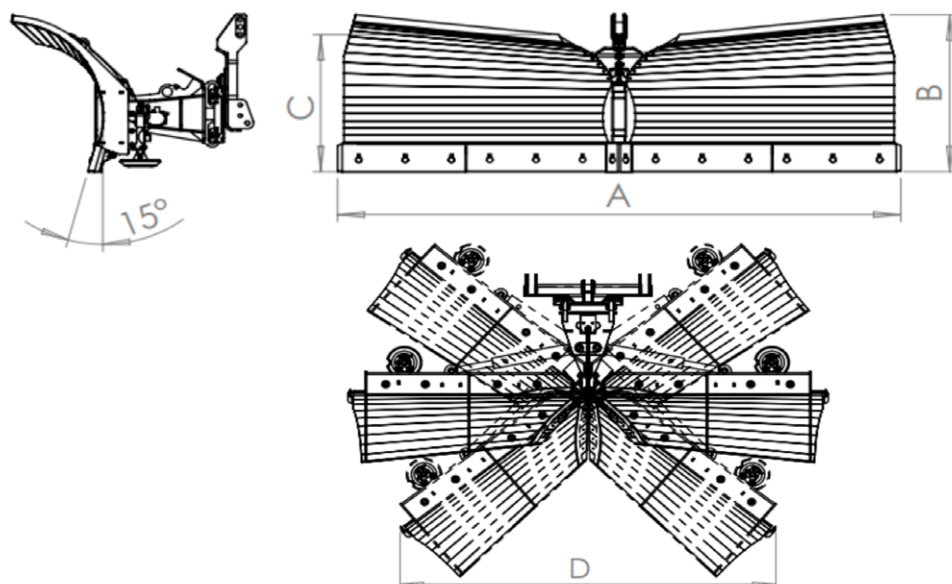

ROAD SNOW PLOUGHS

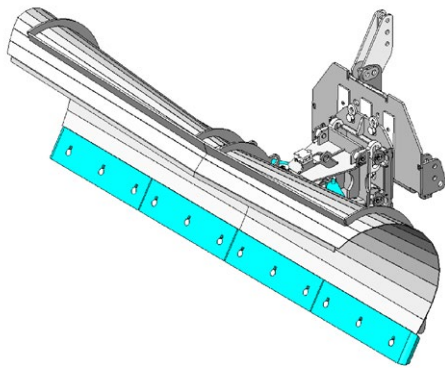

Product	A, mm	B, mm	C, mm	D, mm	Turning angle, °	Positive attack "P" angle, °	Weight, kg
RP2800	2800	1000	750	2250	40+40	30	670
RP3300	3300	1000	750	2550	40+40	30	780
RP3600	3600	1200	850	2800	40+40	30	910
RP4300	4300	1200	850	3300	40+40	30	1050

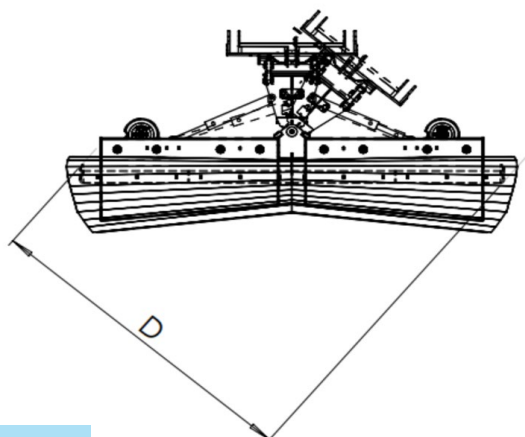
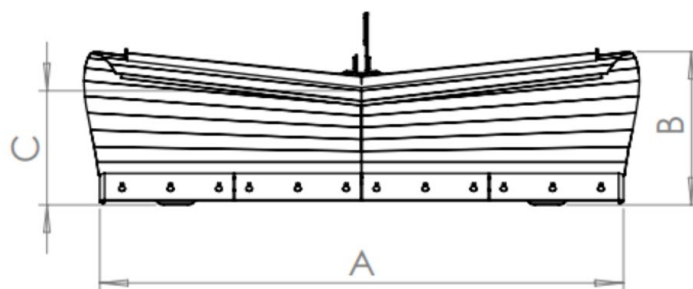
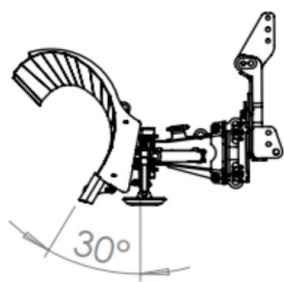

SNOW PLOUGH EXTRAS

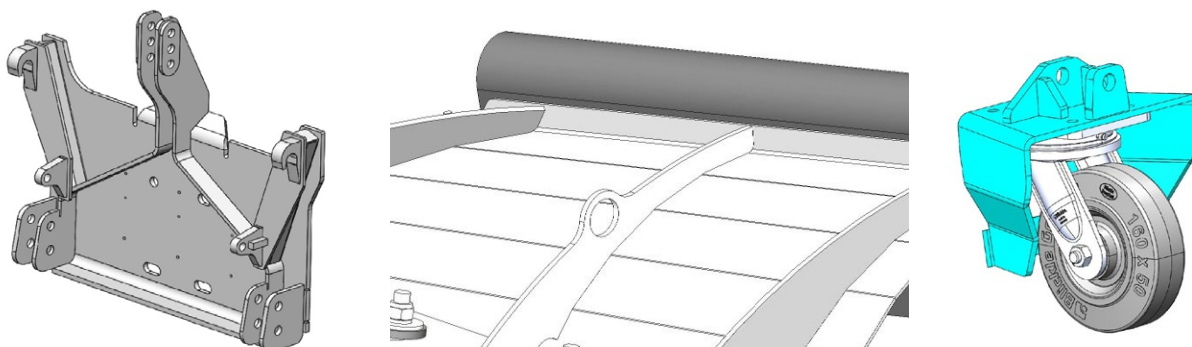

Product	Description
VP LED lights set	VP LED lights set
E6338PV	4 function valve
EASY2	Bluetooth valve controller
EL 2-plug	Valve controller with switch
EL 2-plug-cig	Valve controller into cigarette lighter
Wheel D160mm	Wheel D160mm 15km/h
COMBI	Combi attachment plate
Rubber blades	Rubber blades
Net blades	Net blades HB600
SNR rubbr	Snow dust rubber to front

SNOW BUCKET WITH WINGS

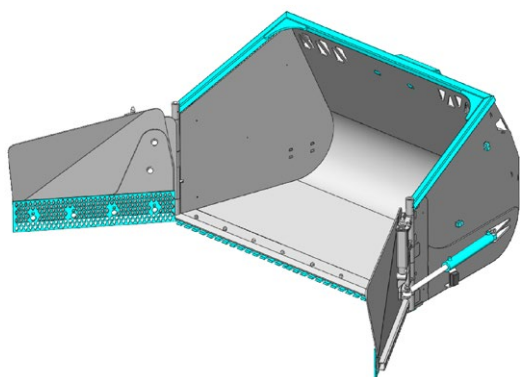

Product	Capacity, l	A, mm	B, mm	C, mm	D, mm	Width, mm	Weight, kg
SBW2000	1700	1200	950	3500	2300	2000	580
SBW2300	2000	1200	950	3800	2600	2300	630
SBW2500	3500	1450	1300	4500	2800	2500	1300
SBW2700	3750	1450	1300	4700	3100	2700	1400
SBW2900	4000	1450	1300	4900	3300	2900	1500

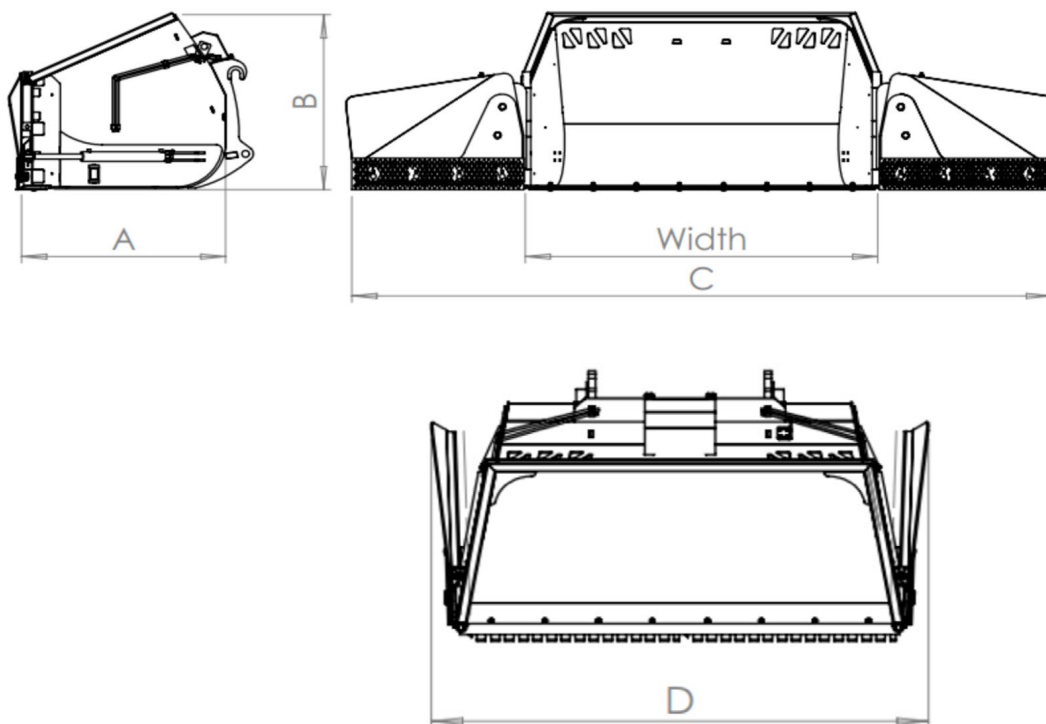

U-PLOUGHS

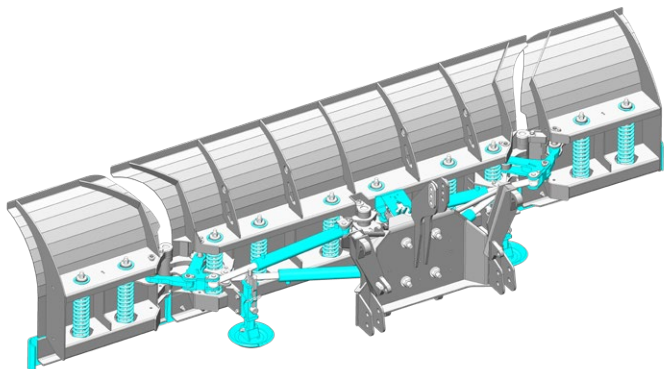

Product	A, mm	B, mm	C, mm	D, mm	E,mm	Turning angle, °	Weight, kg
UP21-36	2100	3600	1000	2550	2200	38+38	900
UP21-40	2100	4000	1000	2550	2200	38+38	920
UP24-39	2400	3900	1000	2850	2500	38+38	940
UP24-43	2400	4350	1000	2850	2500	38+38	970
UP24-49	2400	4950	1000	2850	2500	38+38	1050
UP24-49MAX	2400	4950	1200	2850	2500	38+38	1250
UP28-53	2800	5350	1200	3250	2900	38+38	1350
UP30-55	3000	5550	1300	3500	3200	38+38	1650
UP30-60	3000	6000	1300	3500	3200	38+38	1700

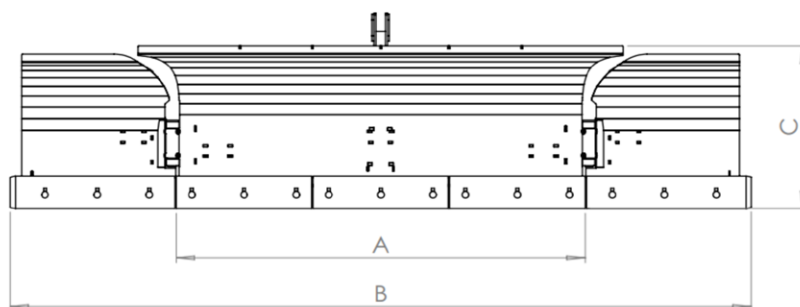
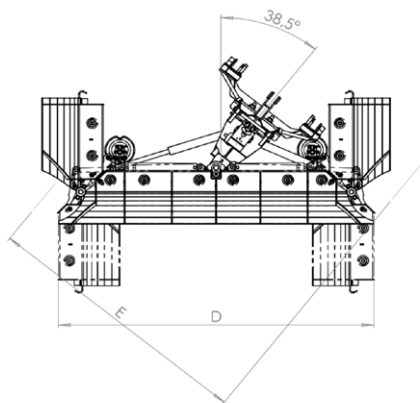

ZOOM-PLOUGHS

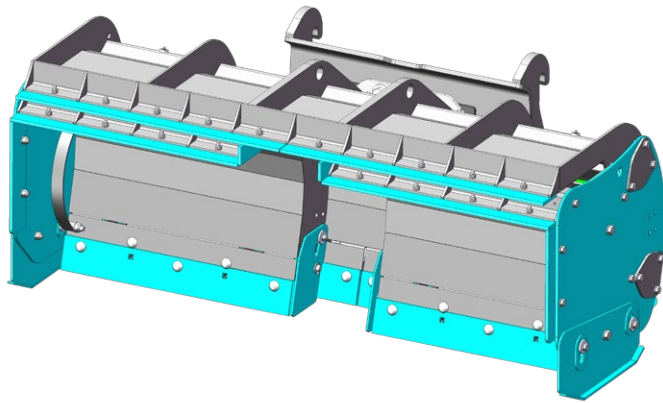

Product	A, mm	B, mm	C, mm	D, mm	Weight, kg
PZ2200	2150	3650	970	890	1050

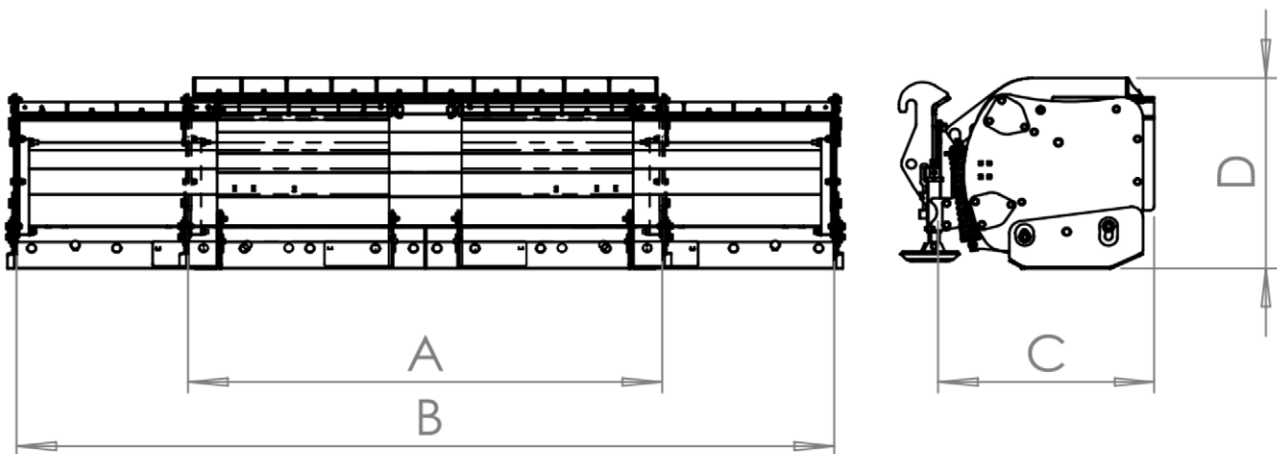

CHAIN MULCHER

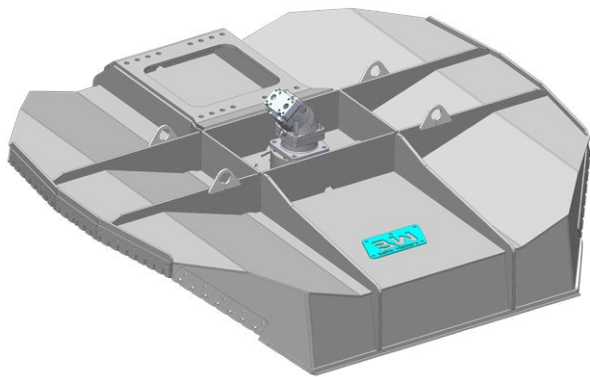

Product	A, mm	B, mm	C, mm	Working width, mm	Weight, kg	Hydraulic motor	Material
CM1500	1700	1700	400	1500	650	64cc	Hardox450
CM1700	1900	1900	400	1700	750	84cc	Hardox450
CM1900	2100	2100	450	1900	850	108cc	Hardox450

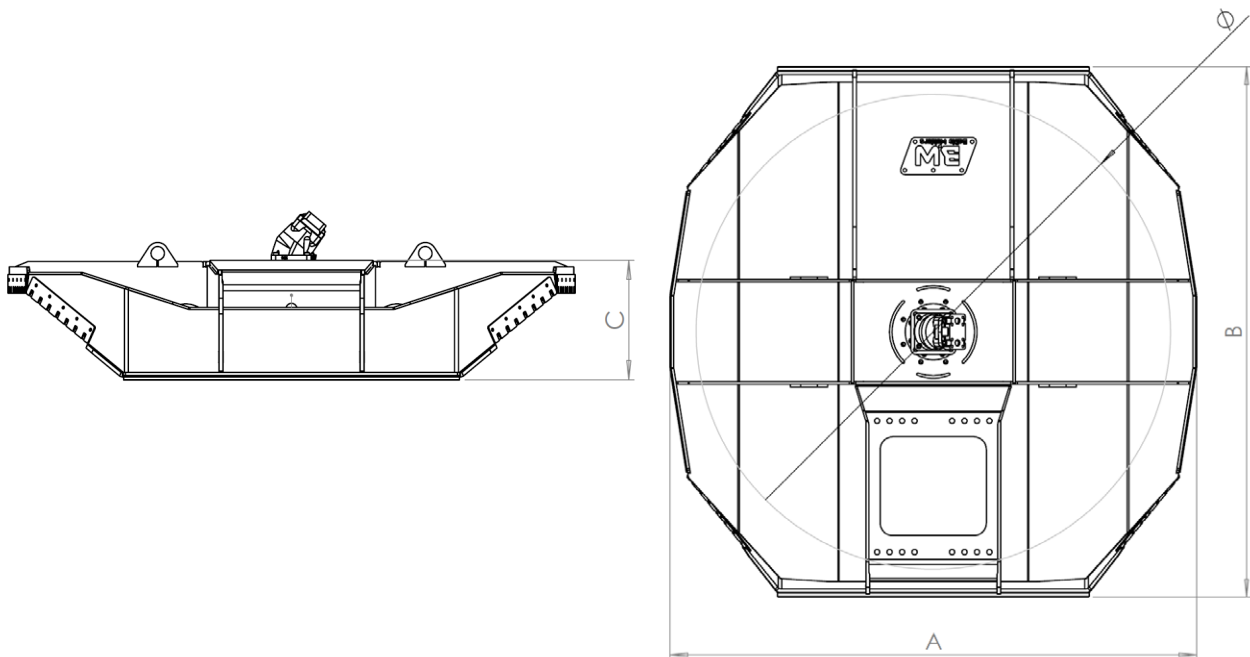

DEMOLITION GRAPPLES



Product	A, mm	B, mm	C, mm	D, mm	Working width, mm	Weight, kg	Grab area, m2	Material
H58CGE	860	1330	1265	770	2200	900	0.58	Hardox450

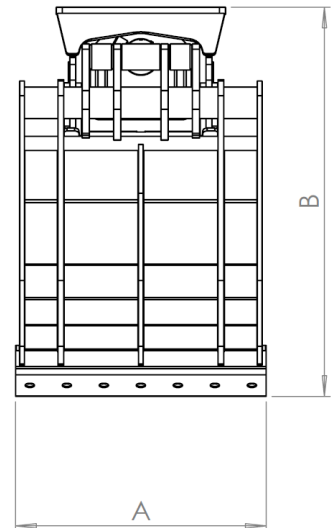
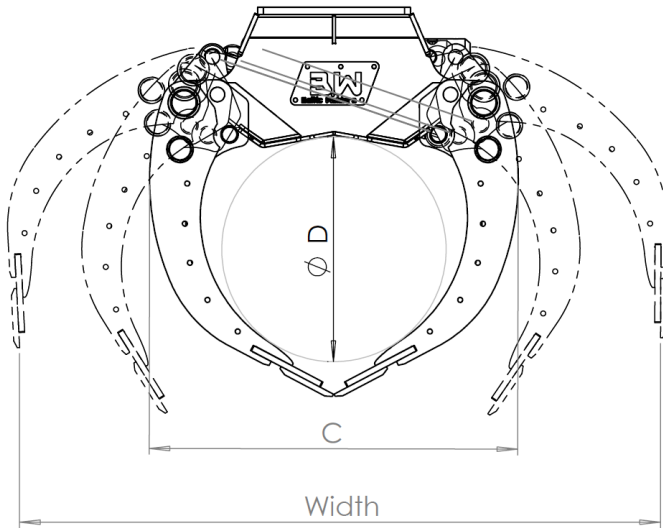

LOG GRAPPLES

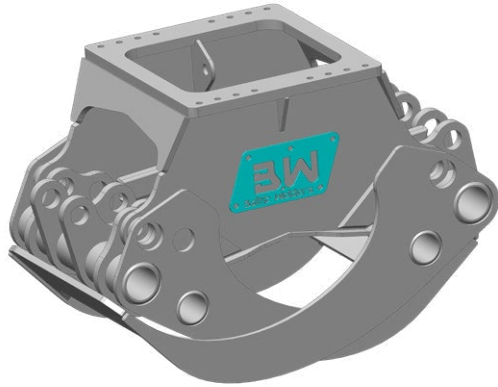

Product	A, mm	B, mm	C, mm	D, mm	Working width, mm	Weight, kg	Grab area, m2	Material
EXC44LOG	620	1330	1065	160	2264	580	0.44	Hardox500TUF

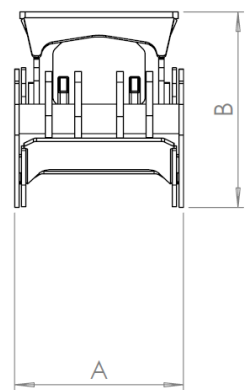
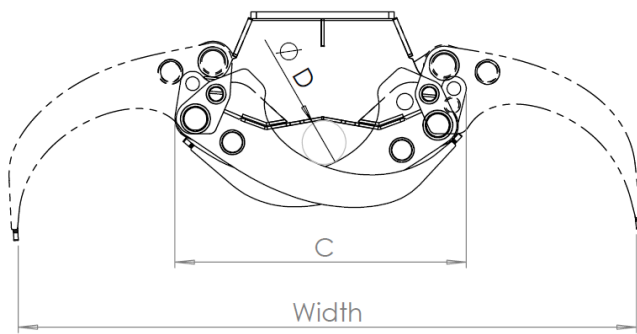

NOTES

A series of horizontal dotted lines for writing notes.

BALTIC WELDERS OÜ

Baltic Welders specialises in manufacturing accessory equipment for construction machinery of the highest quality standard. We have satisfied and gained the trust of our customers through our experience and continuous development in the field of accessory equipment manufacturing.



CONTACT INFO

Address: Keki 9, Näpi, 44305,
Lääne-Viru County, Estonia

Phone: +372 51 329 50
+372 53 077 583

Email: info@balticwelders.ee

www.balticwelders.ee