

## REF. 1455 MEET MARINE DIGITAL PANEL

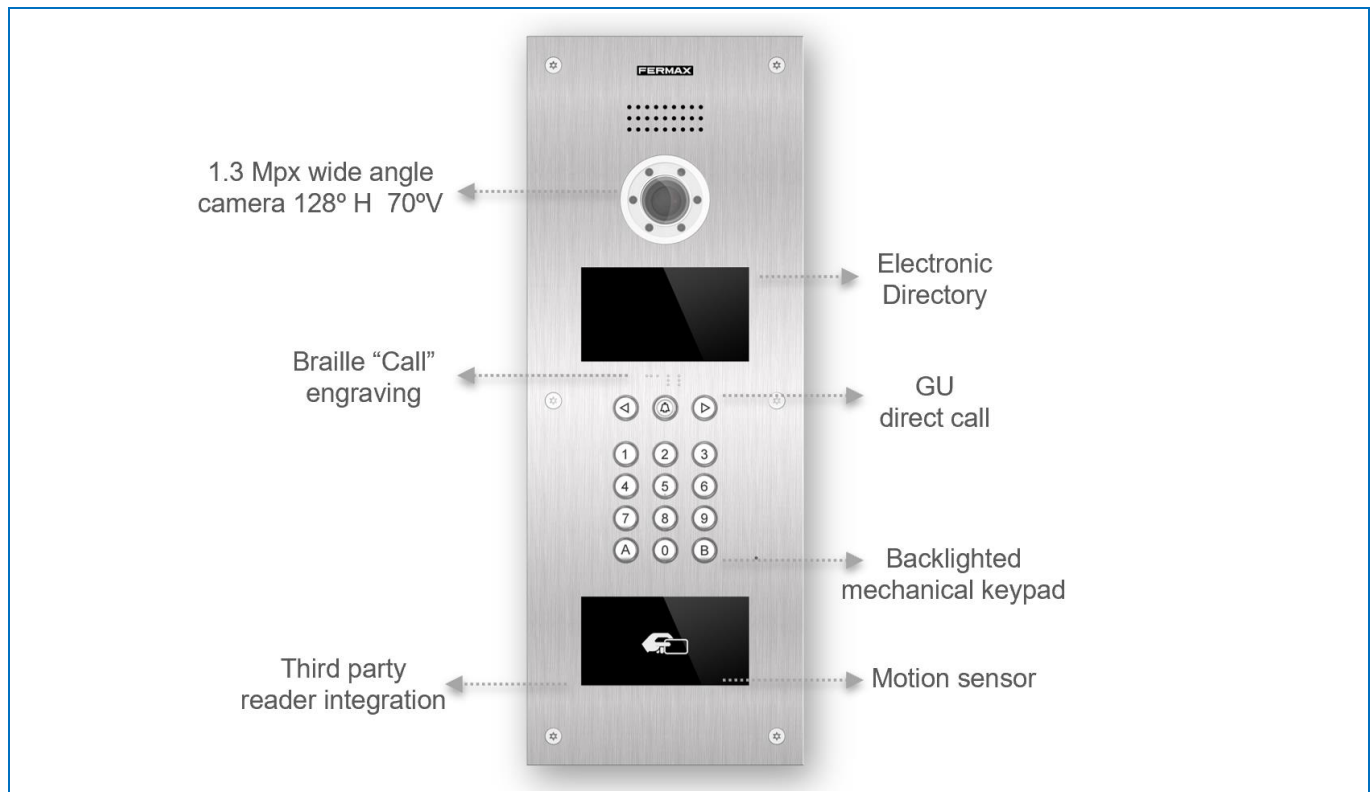

### FEATURES

- 3mm 316L Stainless steel profile
- Backlighting metal keys and braille engraving
- IP54 weatherproof and IK09 resistance
- Hands Free Audio Communication
- 1.3 Mpx High-Definition Colour Camera
- 4.3" Colour TFT Screen
- Electronic Directory with 1 customised image
- Face recognition (up 6000 users)
- RTSP Camera Video Streaming
- Wiegand input/output for third party integration
- Access Control Integrated for 100.000 Cards
- Fire alarm with door unblocking and message to guard unit and MMS.
- Door forced and door left open alarms.
- Voice Synthesizer
- Available in 12 languages
- PoE Powered

### REFERENCES

- Ref. 1455 MEET MARINE DIGITAL VIDEO PANEL
- Ref. 1456 MEET MARINE DIRECTORY PANEL
- Ref. 14591 MEET FLUSH BOX JOINING BOLTS SET (14 mm of separation. 2 units)
- Ref. 1457 MEET MARINE PANEL HOOD
- Ref. 1458 MEET MARINE SURFACE BOX
- Ref. 1459 MEET MARINE FLUSH BOX

## FUNCTIONS

### CALL TENANT

Visitors can call the desired tenant from the General Entry or the Block Entry.

### ELECTRONIC DIRECTORY AND SEARCH

It is possible to store the name of the residents and select them in the electronic directory by scrolling with the arrow keys or selecting the character to search.

### CALL TO GUARD UNIT

If the visitor or tenant needs to be assisted, they can call the main Guard Unit by entering pressing the “Bell Button” or dialing the number 9901. This call can be made from both General Entry and Block Entry.

Up to 98 different guard units can be called (9901...9998).

### ACCESS PIN CODE

It is possible to define up to 8 access codes (pin) to open the door. Codes can have 4 to 6 digits long.

### GUEST CODE

Using the GUEST CODE Module (ref.1494) it is possible to dial a code and be sent to a third-party access control system that generates temporary codes for temporary visitors.

### FACE RECOGNITION

Tenants can be identified in the front of the panel, and then the door been opened by means of pressing twice A key or selecting the function from the menu. Up to 6.000 users.

### PROXIMITY ACCESS CONTROL

The panel includes a Mifare card reader that controls up to 100.000 cards.

It is possible to manage cards by means of the MEET Management Software. In addition, the panel can be connected to third party access control units through Wiegand 26 protocol.

### IP CAMERAS

It is possible to configure up to 4 IP cameras that can be used as an auxiliary camera from all the monitors installed in the same block. These cameras can be used for tracking visitors through the corridors or common areas in the condominium.

### ADDITIONAL RELAYS

It is possible to add up to 4 additional relays. (One Module Ref.1491 is required). Tenants can then open additional doors (garage, corridors, etc.), when called from any panel in their block or main entrance.

### VIDEO STREAMING

RTSP video stream can be constantly sent to NVR or third-party system so that the panel camera can be used as a regular surveillance CCTV camera. Video stream and face recognition cannot work simultaneously.

### TAMPER

The panel is protected against vandalism thanks to the tamper alarm switch, so in case the panel is removed from its flush box a warning message will be sent to concierge and/or MEET Management Software.

### FIRE ALARM

Working with a fire detection system, when activated, an acoustic alarm is triggered in all the panels in the block.

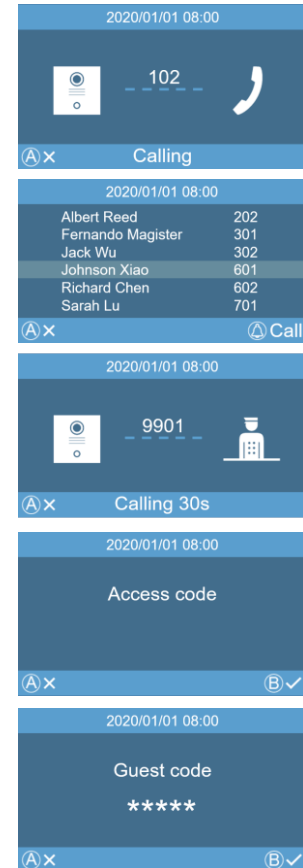

## TERMINALS

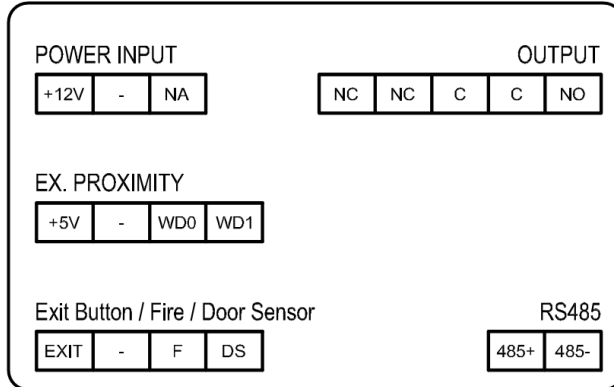

- **RJ-45:** 10/100 Base -T Ethernet. PoE
- **+12V, - :** 12 Vdc power supply
- **EXIT, - : F, DS** Exit pushbutton, fire alarm and opened door sensor connections.
- **+5V, - : WD0, WD1:** 5 Vdc supply for external devices and Wiegand-26 protocol output or input
- **NC, NC, C, C, NO:** Relay output for electric lock terminals.
- **485+, 485- :** RS-485 serial port for lift control & relays.

## TECHNICAL SPECIFICATIONS

### System:

- CPU: Quad-core Cortex™-A7 1.5GHz
- GPU: Mali400MP2
- FLASH: 4GB
- SDRAM: 1GB DDR3L

### Screen:

- 4.3" Color TFT
- Resolution 480 x 272 pixel
- View angle: 110° H, 90° V
- Contrast: 400/1
- Brightness: 200cd/m<sup>2</sup>

### Audio Features:

- G.711 codec
- Audio OLR> 15dB

### Camera:

- 1/3" CMOS Color
- Horizontal 128°, Vertical 70°
- 1.3 Mega Pixels
- Minimum Illumination 0.5 LUX. Automatic white led activation
- AWB

### Built-in MIFARE Classic reader:

- 4-bytes cards only (see ref. 52740/52750)

### Power Consumption:

- On standby: 250 mA
- Working: 500 mA
- Heater enabled: additional 170mA

### Working voltage:

- PoE
- 12 Vdc

### Connectivity:

- Ethernet RJ-45 Connector
- RS485 connection port for lift control and aux relays module.
- Secondary access control reader connection (Wiegand 26)
- Built in web server for configuration and remote management

### Working Environment:

- Temperature: -25°C to +70°C
- Humidity: 10 – 90% (non-condensing)
- IP 54
- IK 09

## DIMENSIONS

