

BCON1(NF/AN)

V.20

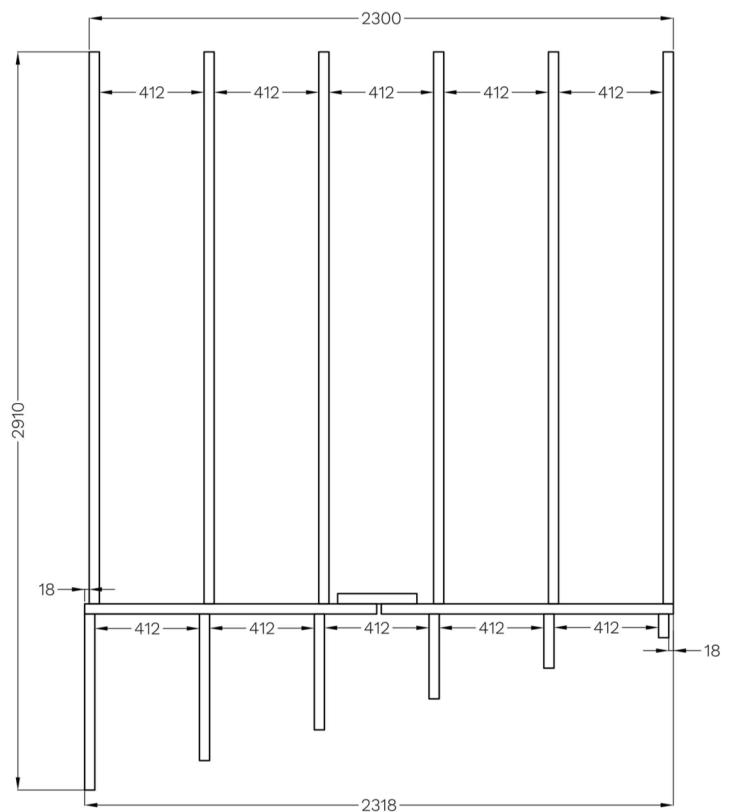
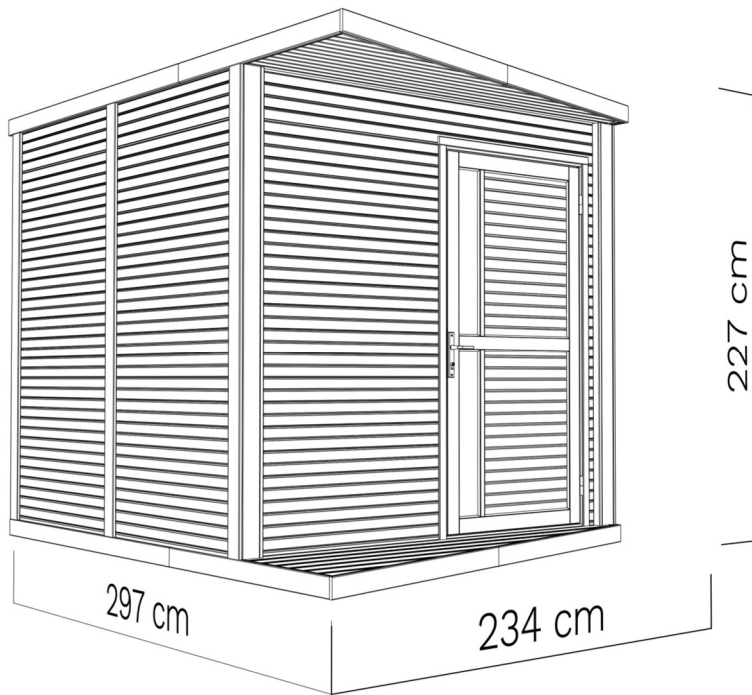

DE - Technische Änderungen vorbehalten.

Alle Maße sind ca. Maße.

EN - Technical modifications reserved.

All dimensions are approximate dimensions.

FR - Sous réserve de modifications techniques.

Toutes les dimensions sont approximatives.



BCON1(NF/AN)

DE **Bevor Sie beginnen**

• Es ist empfehlenswert sich etwas Zeit zu nehmen, um die Aufbauanleitung anzusehen, bevor mit dem Aufbau begonnen wird. • Alle Schritte für den Aufbau werden – auch in Detailbildern – dargestellt. • Die vorgegebene Reihenfolge ist zu beachten. • Bitte prüfen Sie vor dem Aufbau anhand der Teileliste die Vollständigkeit und den Zustand der Lieferung. • Besonders wichtig ist der Holzschutz! Die Boden-elemente sind vor dem Aufbau von unten mit einem geeigneten Holzschutz zu behandeln! • Das für die meisten Produkte online verfügbare Datenblatt bietet weitere wichtige Hinweise für den Aufbau. • Beigefügt sind auch die Garantiebedingungen.

FR **Avant de commencer**

• il est recommandé de prendre le temps de lire les instructions de montage avant de commencer. • Toutes les étapes du montage sont présentées, y compris sur des illustrations détaillées. • L'ordre prescrit doit être respecté. • Avant le montage, vérifiez l'exhaustivité et l'état de la livraison à l'aide de la liste des pièces. • La protection du bois est particulièrement importante! Avant le montage, les éléments de plancher doivent être traités par le bas avec un produit de protection du bois approprié! • La fiche technique disponible en ligne pour la plupart des produits fournit d'autres informations importantes pour le montage. • Les conditions de garantie y sont également jointes.

CZ **Než začnete**

• Doporučujeme, abyste si vzali trochu času k prohlédnutí montážního návodu, než s montáží začnete. • Všechny montážní kroky jsou zobrazeny - také na podrobných obrázcích. • Je nutné dodržovat uvedený postup. • Před montáží zkontrolujte podle seznamu dílů, zda jste obdrželi všechny díly a zda je dodávka v dobrém stavu. • Obzvláště důležitá je dřevěná botka! Podlahové prvky musí být před montáží zespoda ošetřeny vhodným ochranným přípravkem na dřevo! • Datový list, který je k dispozici online pro většinu produktů, poskytuje další důležité pokyny k montáži. • V příloze naleznete také záruční podmínky.

DK **Før du starter**

• Det kan anbefales at tage sig tid til at kigge på samlevejledningen, før du starter samlingen. • Alle trin i samlingen bliver vist – også i detaljerede billeder. • Overhold den angivne rækkefølge. • Kontrollér, at leveringen er fuldstændig og i den rette tilstand ved hjælp af delelisten, før du starter samlingen. • Særligt vigtig er træbeskyttelsen! Gulvelementerne skal behandles med egnede træbeskyttelse nedefra, før du starter samlingen! • Til de fleste produkter kan du finde datablade online, der indeholder yderligere vigtige informationer til samlingen. • Garantibetingelserne er også vedlagt.

NL **Voordat u begint**

• Het is aan te bevelen om de tijd te nemen om de opbouwhandleiding door te nemen voordat er met het opbouwen wordt begonnen. • Alle stappen voor het opbouwen worden - ook met gedetailleerde afbeeldingen - weergegeven. • Neem de aangegeven volgorde in acht. • Controleer voor het opbouwen aan de hand van de onderdelenlijst de volledigheid en de hoedanigheid van de levering. • Bijzonder belangrijk is de bescherming van het hout! De vloerelementen moeten voor het opbouwen van anderen met een geschikt houtbeschermingsmiddel worden behandeld! • Het voor de meeste producten online beschikbare gegevensblad bevat verdere belangrijke aanwijzingen voor de opbouw. • Bijgevoegd zijn ook de garantie bepalingen.

PL **Przed rozpoczęciem**

• Wskazane jest, aby przed przystąpieniem do montażu zapoznać się z instrukcją montażu. • Pokazane są wszystkie etapy montażu – również na szczegółowych zdjęciach. • Należy przestrzegać podanej kolejności. • Przed montażem należy skorzystać z listy części, aby sprawdzić, czy dostawa jest kompletna i w dobrym stanie. • Ochrona drewna jest szczególnie ważna! Przed montażem elementy podłogowe należy zabezpieczyć od dołu odpowiednim środkiem do konserwacji drewna! • Arkusz danych, który jest dostępny online dla większości produktów, zawiera dalsze ważne informacje dotyczące montażu. • Załączone są również warunki gwarancji.

SV **Innan du börjar**

• Vi rekommenderar att du åsidosätter lite tid för att titta igenom monteringsanvisningen innan du påbörjar monteringen. • Alla monteringsstegen visas – även med detaljerade bilder. • Den angivna ordningen måste följas. • Kontrollera att leveransen är komplett och i gott skick innan monteringen påbörjas med hjälp av listan över delar. • Träskyddet är av yttersta vikt! Golvelementen ska behandlas underifrån med lämpligt träskyddsmedel före monteringen! • Annan viktig information före montering finns i databladet (tillgängligt online för de flesta produkter). • Garantivillkoren bifogas också.

RO **Înainte să începeți**

• Vă recomandăm să dedicați puțin timp pentru a consulta Instrucțiunile de asamblare înainte de a începe asamblarea. • Toate etapele de asamblare sunt prezentate amănunțit - și în forma unor figuri detaliate. • Respectați ordinea specificată. • Înainte de asamblare, vă rugăm să verificați lista de componente pentru a vă asigura că furnitura este completă și în stare bună. • Acordați o deosebită atenție protecției lemnului! Elementele de podea trebuie tratate de dedesubt cu o substanță conservantă adecvată pentru protecția lemnului înainte de asamblare! • Fișa de date, care este disponibilă și online pentru majoritatea produselor, oferă informații suplimentare importante cu privire la asamblare. • Atașat veți găsi și condițiile de garanție.











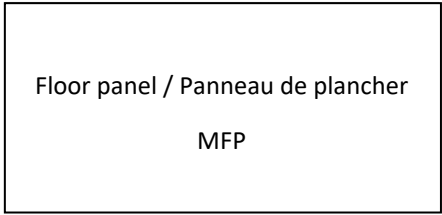
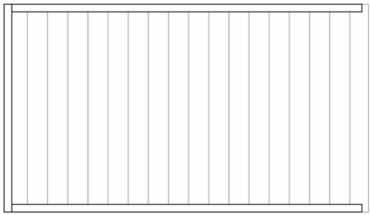
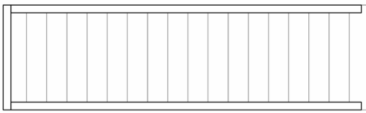





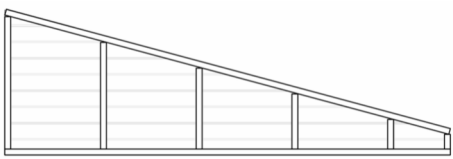
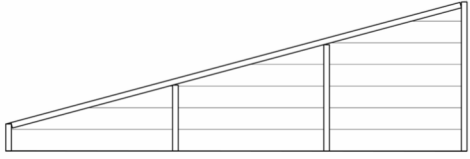

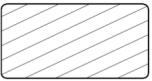
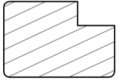
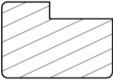

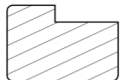

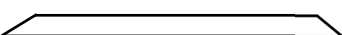
EE **Soovitused enne paigalduse alustamist**

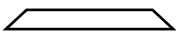
• Soovitame enne paigalduse alustamist võtta aega ja tutvuda paigaldusjuhendiga. • Kõik kokkupaneku etapid on näidatud ka üksikasjalikel piltidel. • Paigaldustööd tuleks teha etteantud järjekorras. • Enne paigalduse alustamist kontrollige detailide nimekirja alusel, kas kõik elemendid on olemas ja ega need pole kahjustada saanud. • Puidukaitse on eriti oluline! Põrandaelemente tuleb enne kokkupanekut töödelda altpoolt sobiva puidukaitsevahendiga! • Andmeleht, mis on enamiku toodete kohta internetis saadaval, pakub kokkupanekuks täiendavat olulist teavet. • Lisatud on ka garantiitingimused.

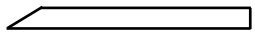

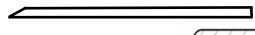



















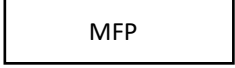

EN **Before assembly**

• We recommend that time is taken to read the assembly instructions prior to assembly. • All assembly steps are shown – also in detailed images. • The step-by-step instructions must be followed. • Before assembly, please use the parts list to check that all components are accounted for and in good condition. • Wood protection is particularly important! The floor elements must be treated from below with a suitable wood preservative before assembly! • The data sheet, which is available online for most products, offers further important information for assembly. • The guarantee conditions are also attached.



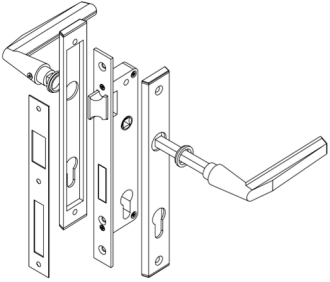
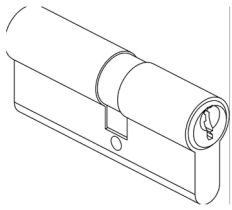
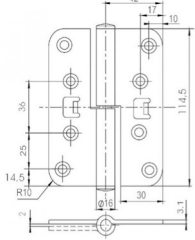





BCON1(NF/AN)

ID	Details in mm (Tolerance/Toleranz ...+ 2mm)	Pcs.	ID	Details in mm (Tolerance/Toleranz ...+ 2mm)	Pcs.
1112	16 x 1109 x 2300  Floor panel / Panneau de plancher MFP	x 2	351	58 x 1109 x 1953 	x 6
352	58 x 554 x 1953 	x 2	358	58 x 120 x 1953 	x 1
359	58 x 228 x 2218 	x 1	360	58 x 304 x 2218 Left side/ die Linke 	x 1
361	58 x 304 x 2218 Right side / die Recht 	x 1	362	58 x 224 x 2218 	x 1
363	44 x 690 x 2300 	x 1	364	44 x 751 x 2300 	x 1
34	32 x 920 x 1868 	x 1	559	150 x 835 Plexiglas 	x 2
902	40 x 80 x 2218 	x 5	860	40 x 60 x 989 	x 1
944	40 x 60 x 1878  	x 1	867	40 x 60 x 1878  	x 1
1098	28 x 28 x 2140 	x 2	1094	41 x 41 x 2000  	x 1
857	40(41) x 60(41) x 500  	x 8	1083	41 x 41 x 1000  	x 10
1125	19 x 90 x 2150 	x 4	1085	19 x 90 x 1235  	x 8
1086	19 x 90 x 1235 	x 2	1087	19 x 90 x 1860 	x 2

BCON1(NF/AN)

ID	Details in mm (Tolerance/Toleranz ...+ 2mm)	Pcs.	ID	Details in mm (Tolerance/Toleranz ...+ 2mm)	Pcs.
1088	12 x 830 x 1150 	x 1	1089	19 x 90 x 1205 	x 3
1126	19 x 90 x 2130 	x 8	1091	19 x 45 x 2155 	x 4
732	19 x 45 x 989 	x 1	1128	19 x 45 x 1150 	x 6
1092	12 x 42 x 1905 	x 2	1095	12 x 522 x 1150 	x 1
577	12 x 42 x 1040 	x 1	1127	19 x 90 x 1168 	x 2
946	15 x 16 x 154 	x 4	945	15 x 15 x 807 	x 4
516	12 x 830 x 1150 	x 4	707	15 x 15 x 909 	x 1
1500	∅5 x 120 	x 5	1093	12 x 550 x 1150 	x 2
1502	∅4,5 x 70 	x230	1501	∅4,5 x 90 	x 12
1506	∅3,5 x 35 	x289	1505	∅4,5 x 50 	x 120
1510	∅1,5 x 25 	x 32	1510	∅3 x 19 	x 8
1531		x 1	1554	ES60 (30/30) 	x 1
1527	Righthand hinge 	x 2	1557	VR1515 Ventilation rest 	x 2
1135	15 x 15 x 838 	x 4	1129	15 x 15 x 154 	x 4

BCON1(NF/AN)

ID	Details in mm (Tolerance/Toleranz ...+ 2mm)	Pcs.	ID	Details in mm (Tolerance/Toleranz ...+ 2mm)	Pcs.
1117	40 x 60 x 2177 	x 6	1118	40 x 60 x 1150 	x 2
1119	40 x 60 x 693 	x 1	1120	40 x 60 x 577 	x 1
1121	40 x 60 x 456 	x 1	1122	40 x 60 x 334 	x 2
1123	40 x 60 x 213 	x 1	1124	40 x 60 x 93 	x 1
1113	41 x 41 x 2218 	x 6			

NB! Empfohlen bei Aufbau auf besonders feuchtem Untergrund. (**Nicht im Lieferumfang enthalten!**)
Recommended for assembly on moist ground. (**Not included!**)

* Unterlegpads

* Patio Pads

* Plots en caoutchouc atio Pads

Min. 16 lfm/rm



Fundamentplan / Foundation Plan / Plan de

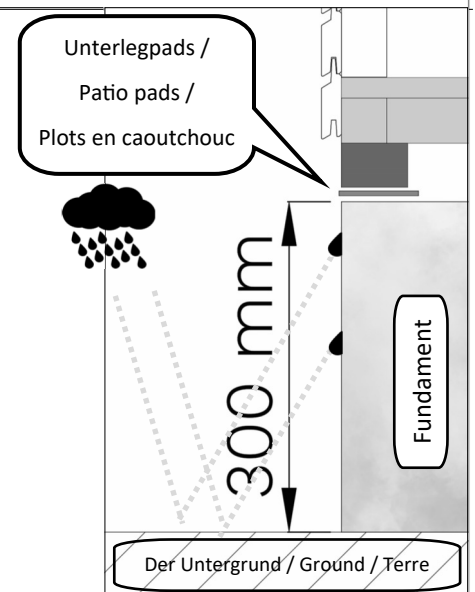
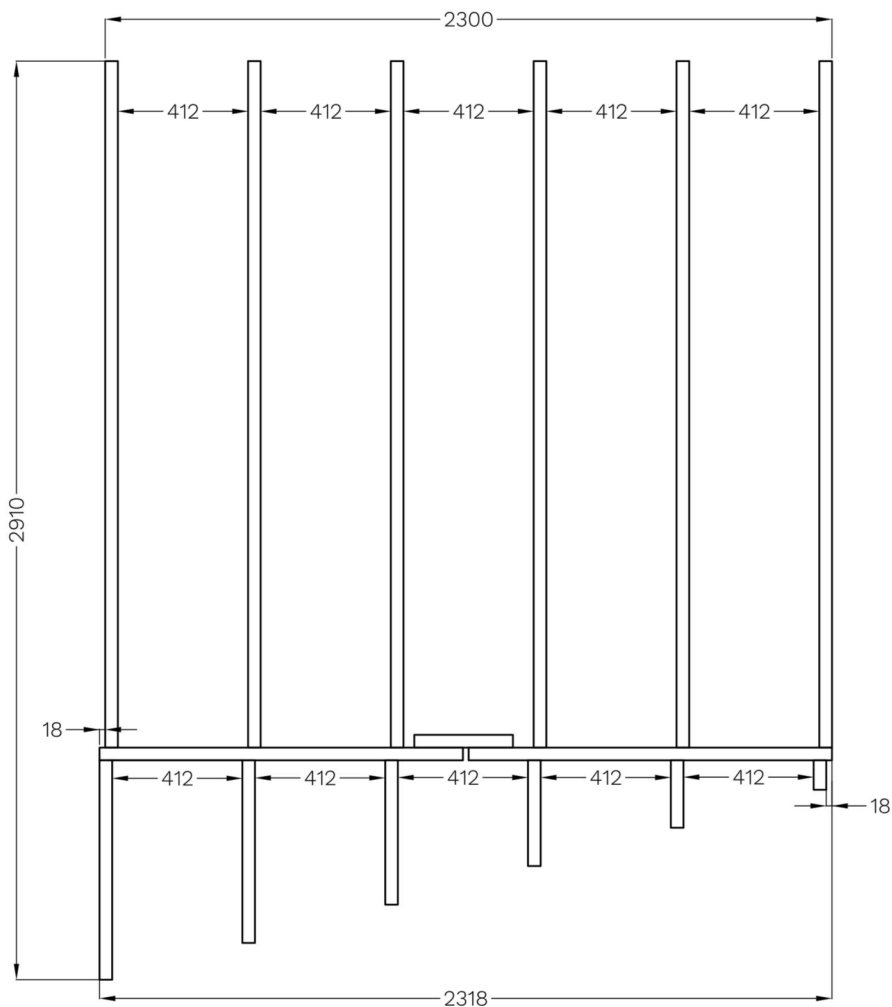

Vor dem Aufbau!

Bitte erkundigen Sie sich vor der Montage, ob für den Bau eine Genehmigung erforderlich ist.

Before installation!

Prior to assembly please check whether a permit is required.

Avant d'installer!

Avant la construction assurez-vous d'avoir le permis de construction.

BCON1(NF/AN)

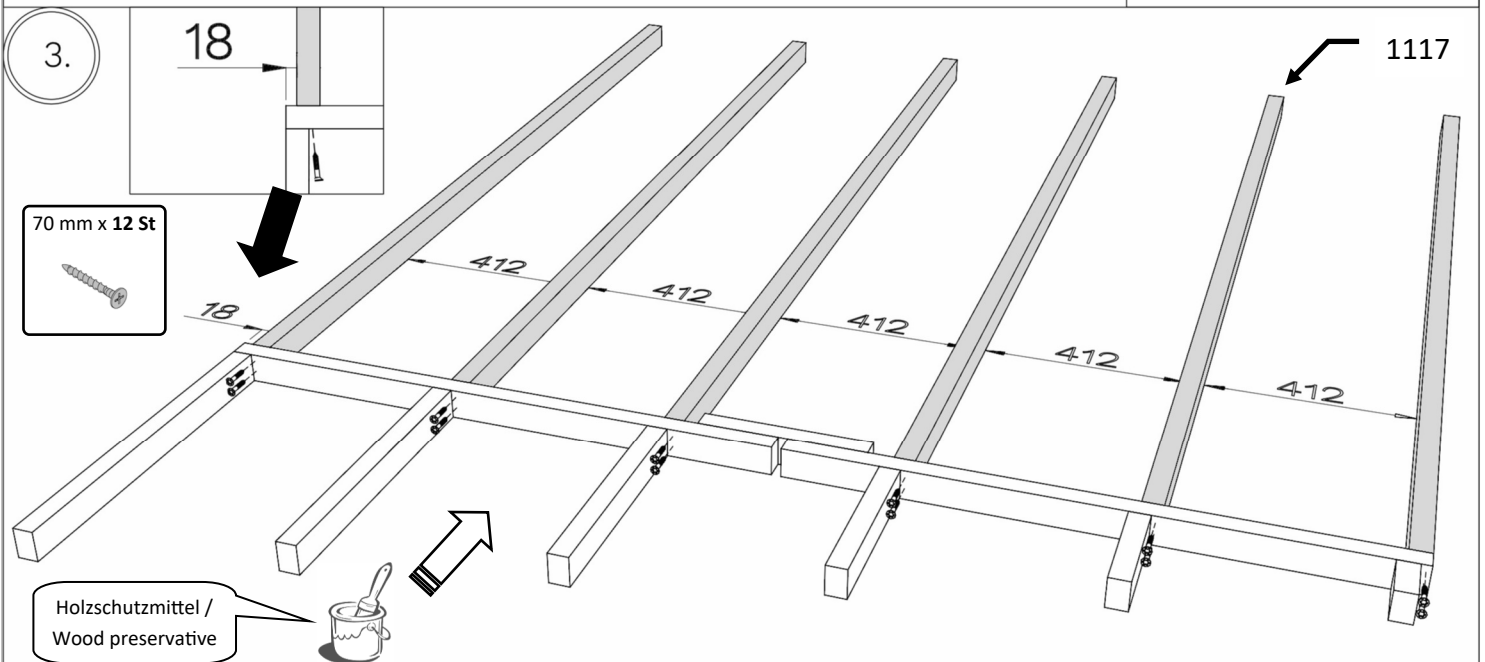
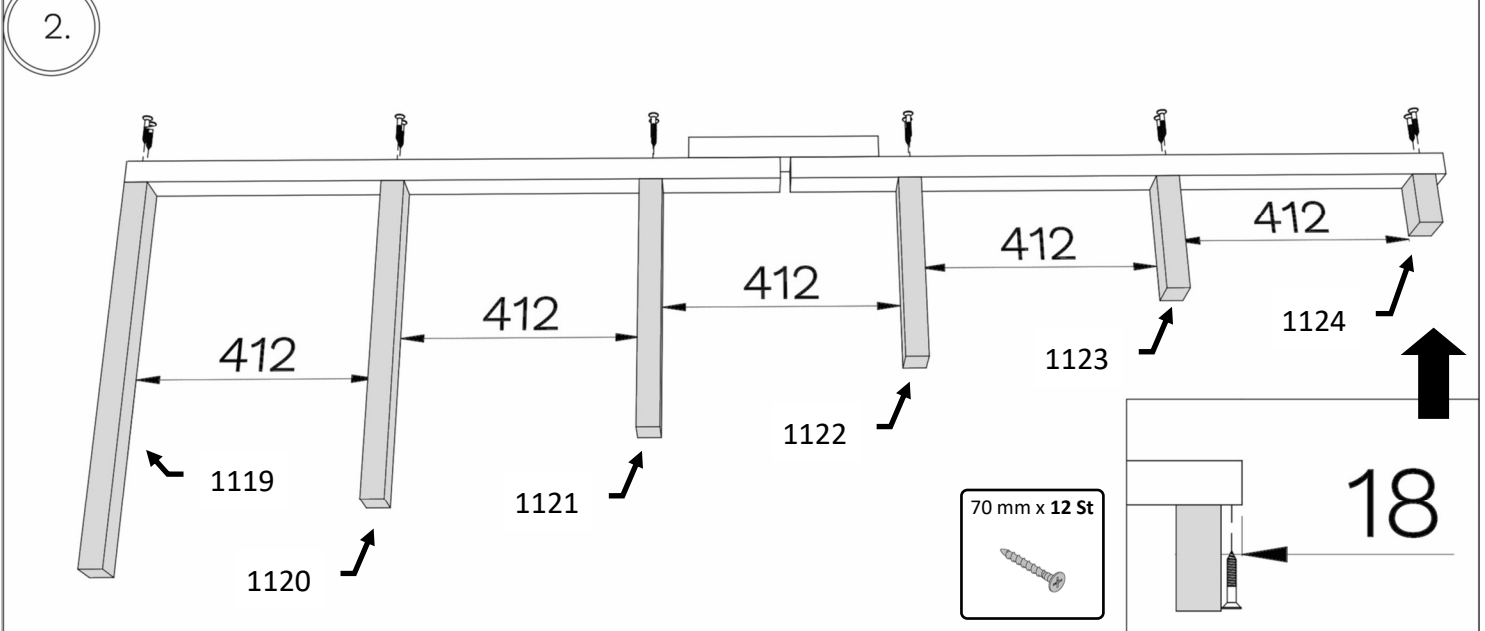
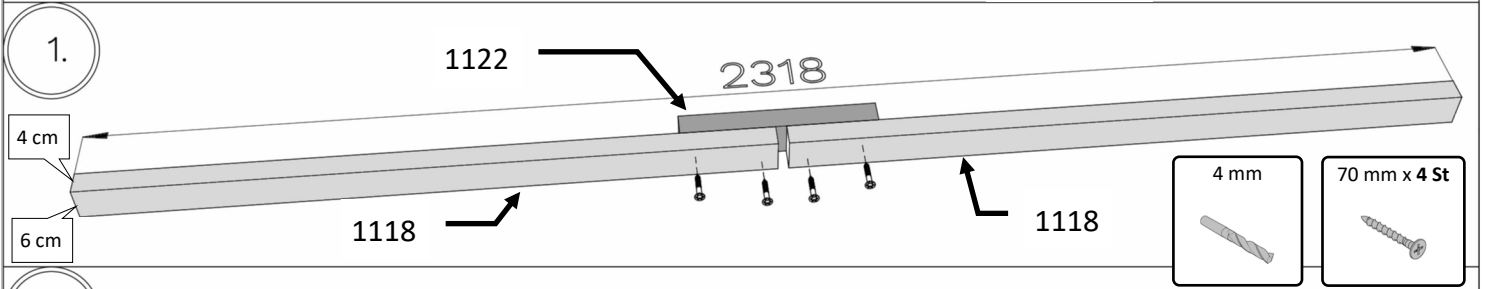
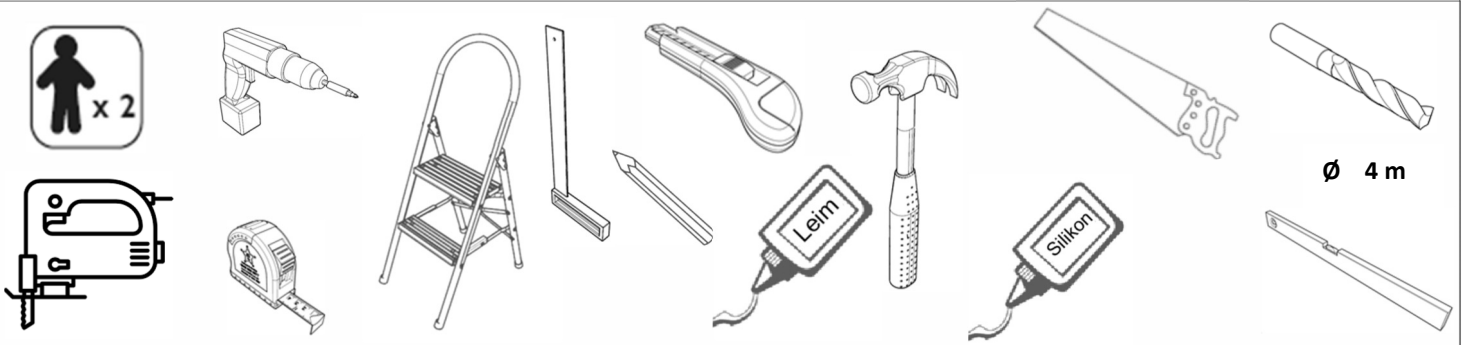

BCON1(NF/AN)

4.

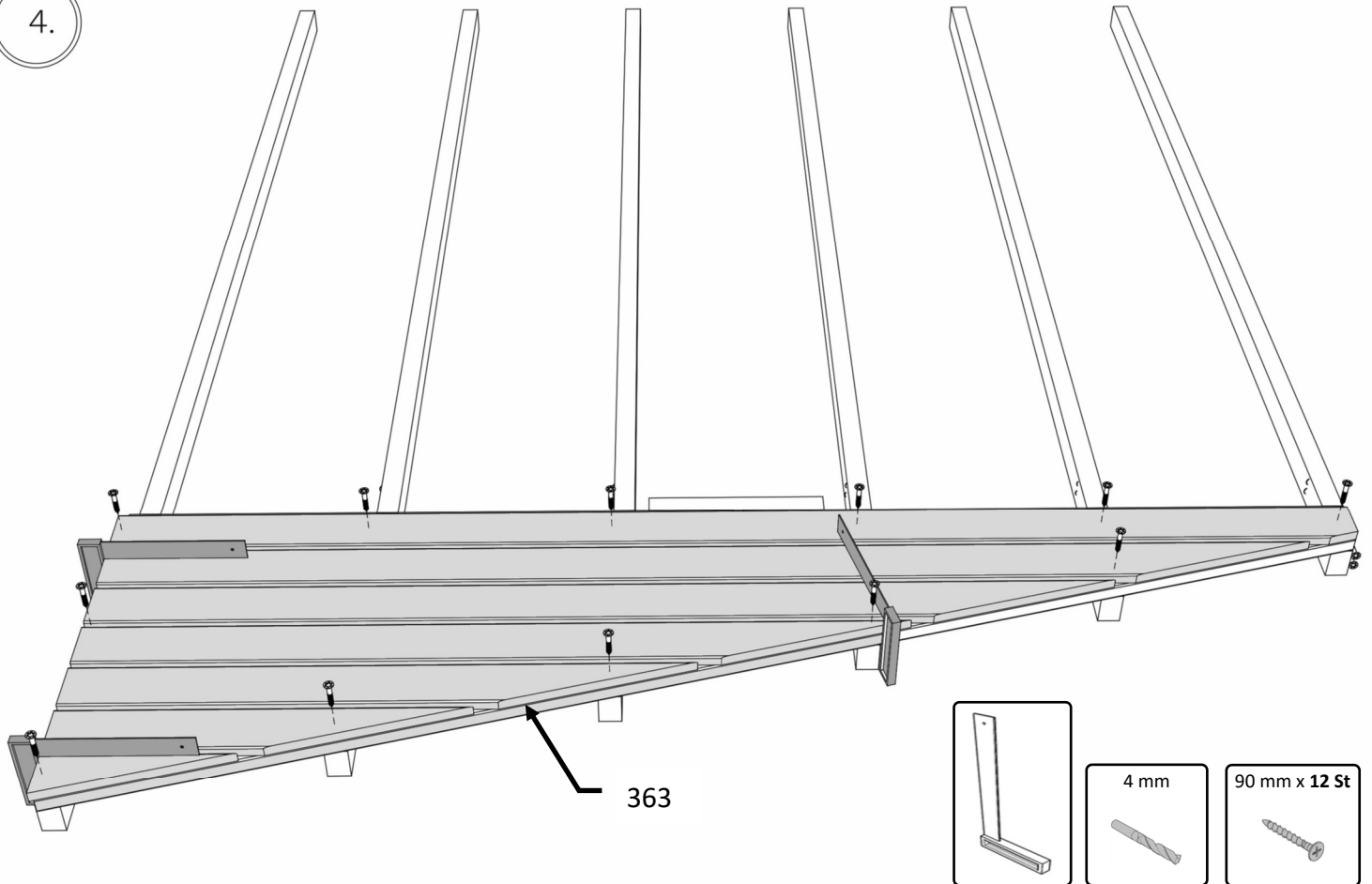

5.

4 mm

70 mm x 30 St

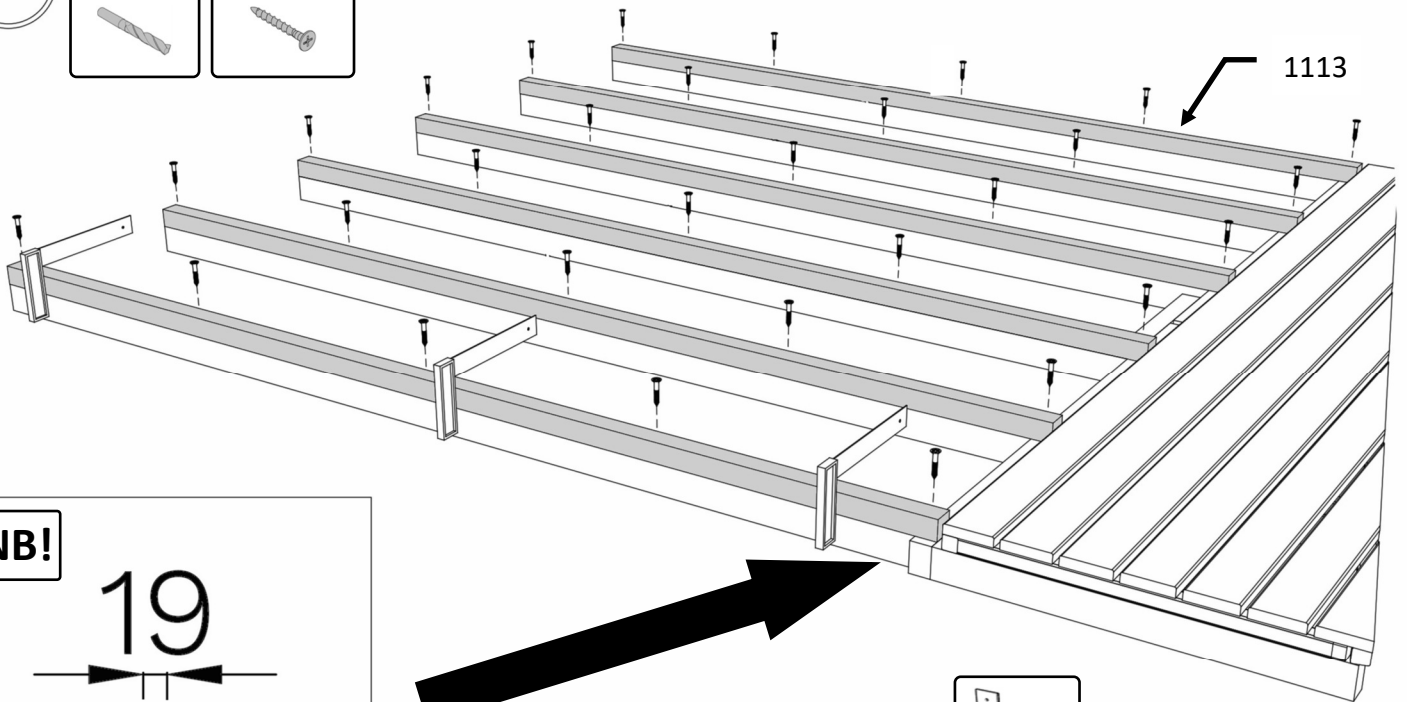

NB!

19

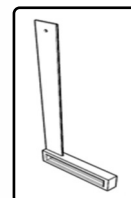
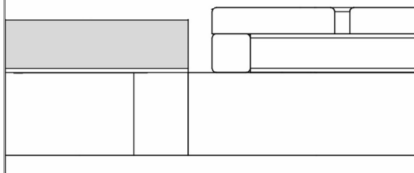

BCON1(NF/AN)

6.

4 mm



50 mm x 36 St

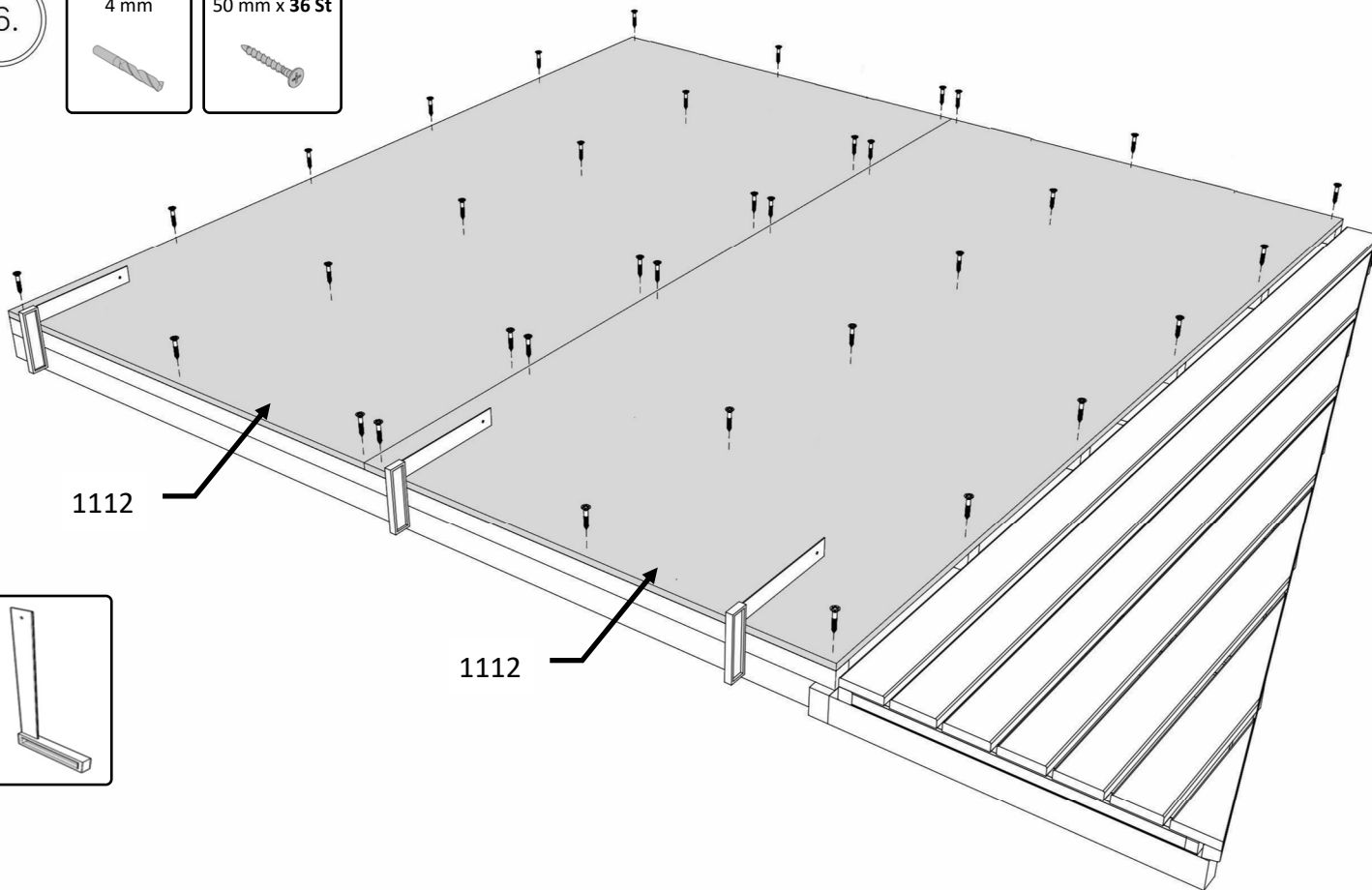

1112

1112

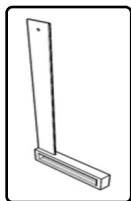

7.

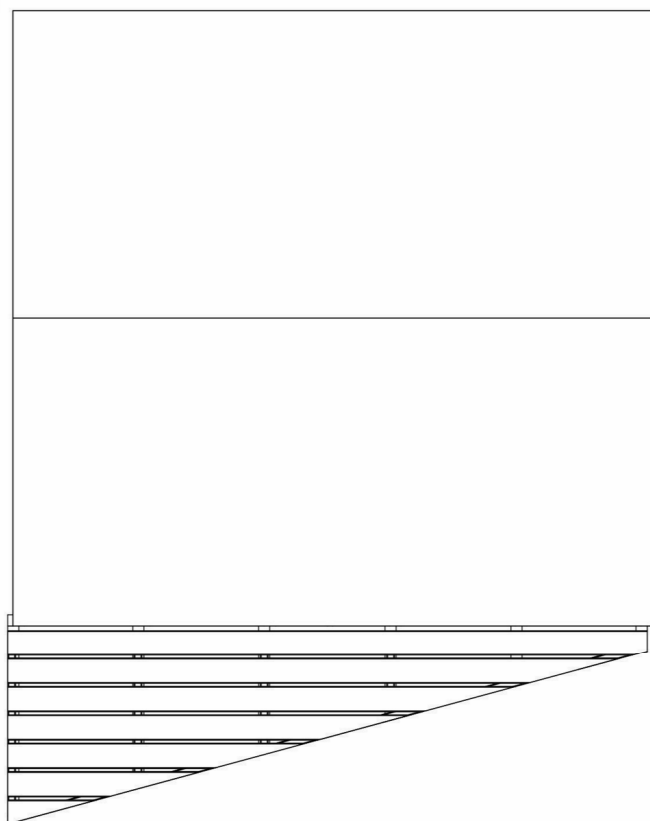

7.1

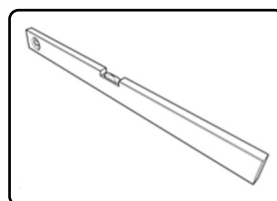
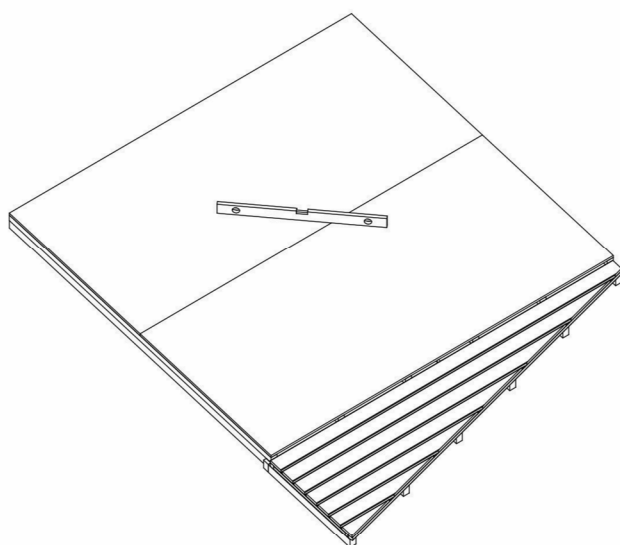

BCON1(NF/AN)

8.

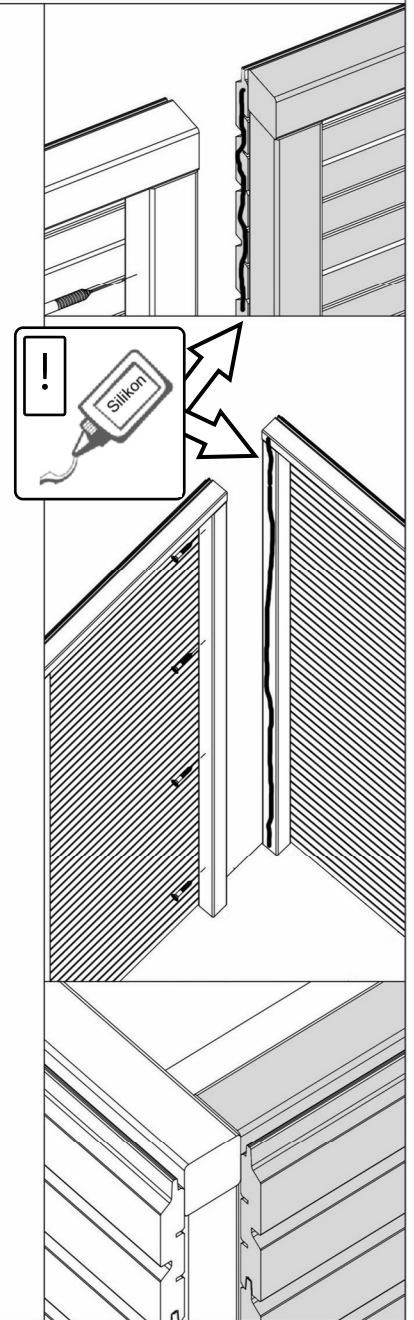
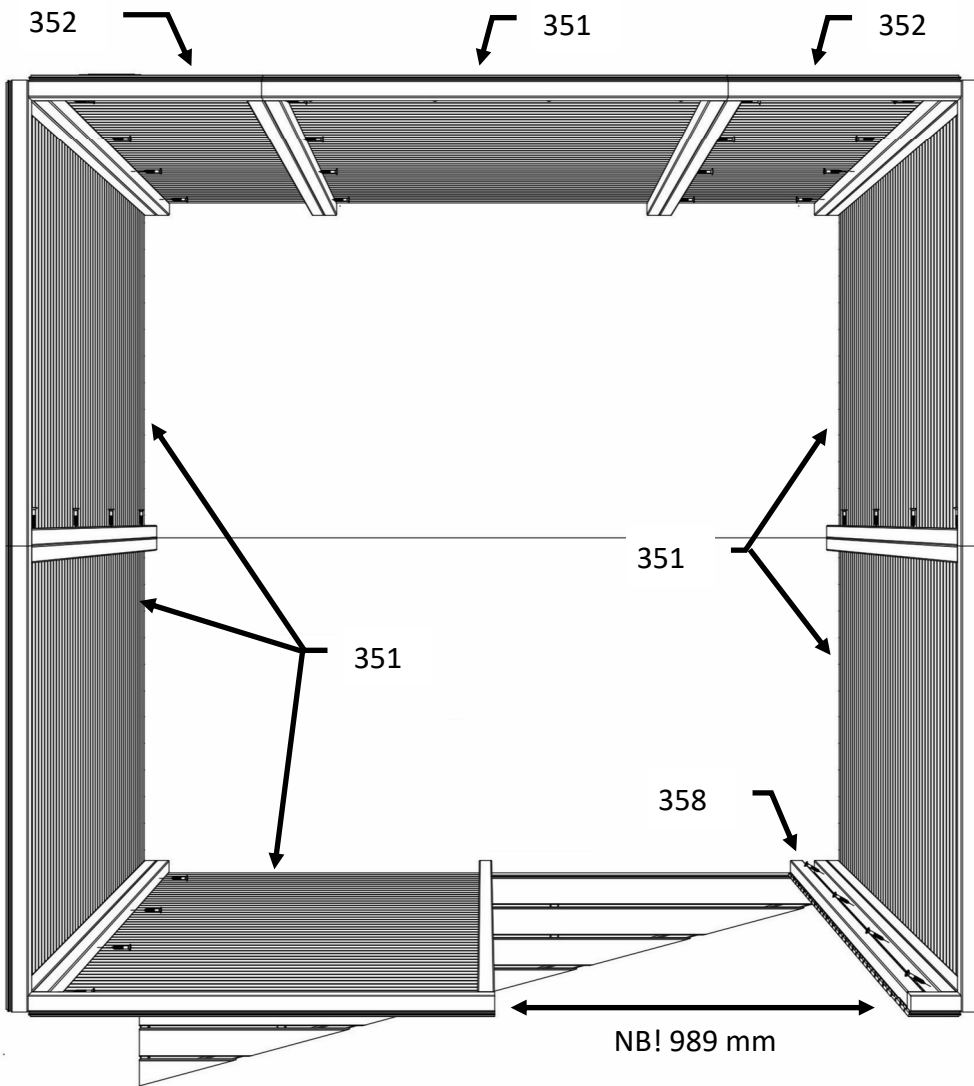

9.

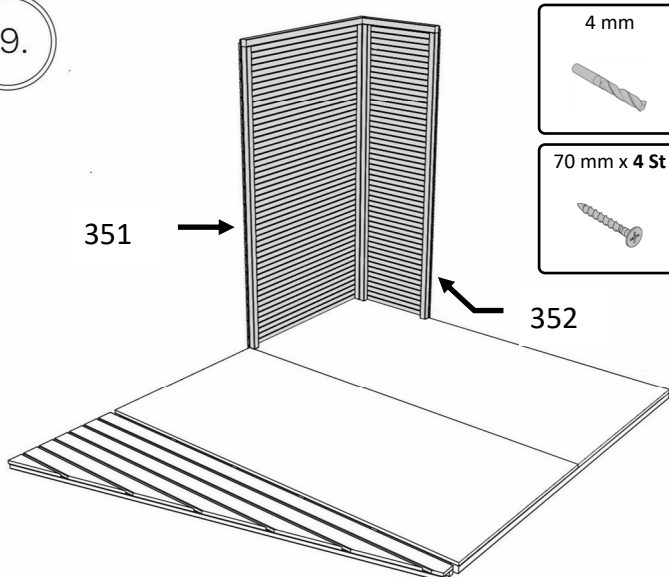

4 mm



70 mm x 4 St



10.

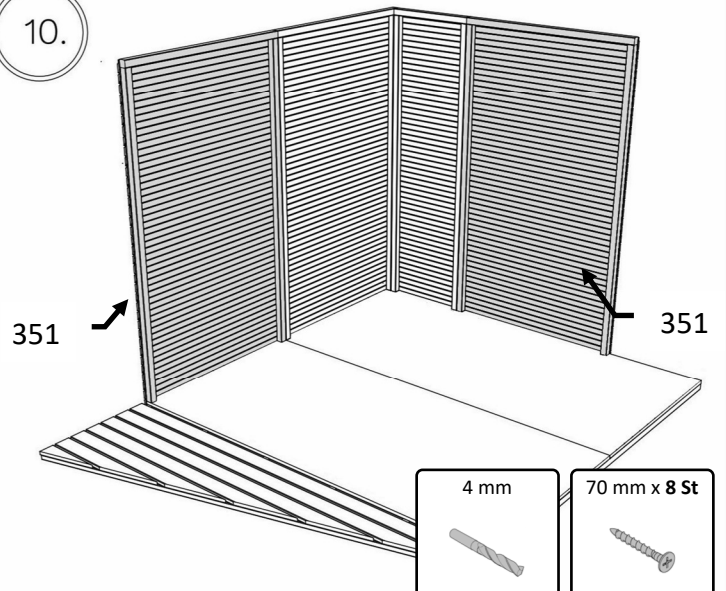

4 mm



70 mm x 8 St



BCON1(NF/AN)

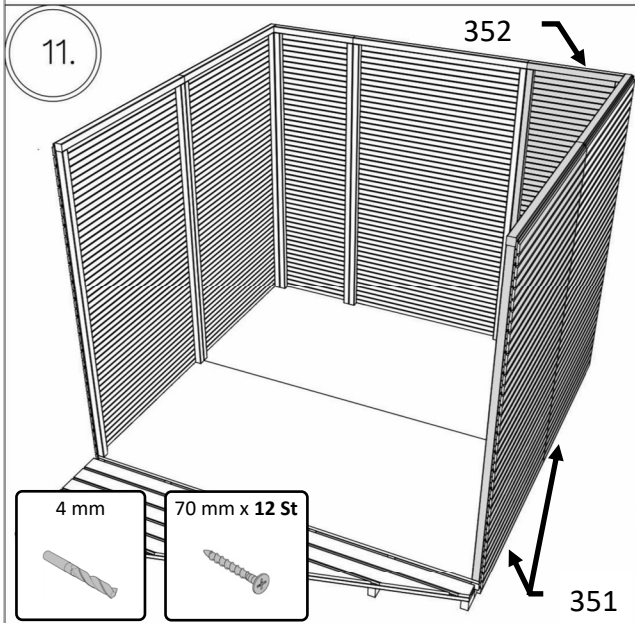

2)

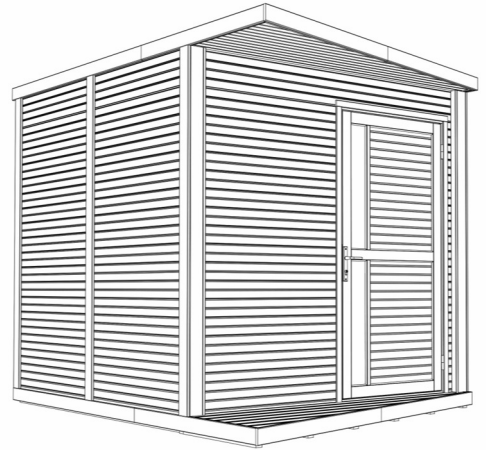

1)

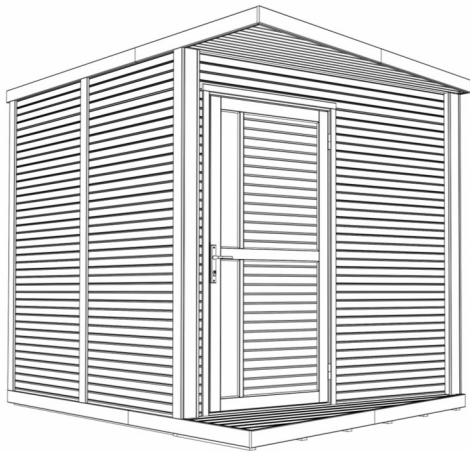

12.

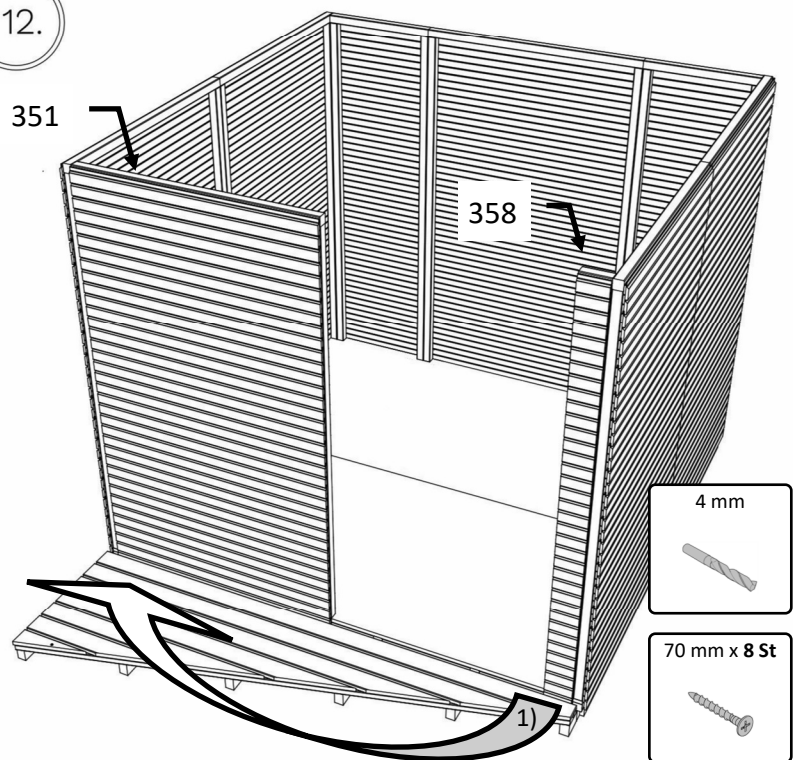

13.

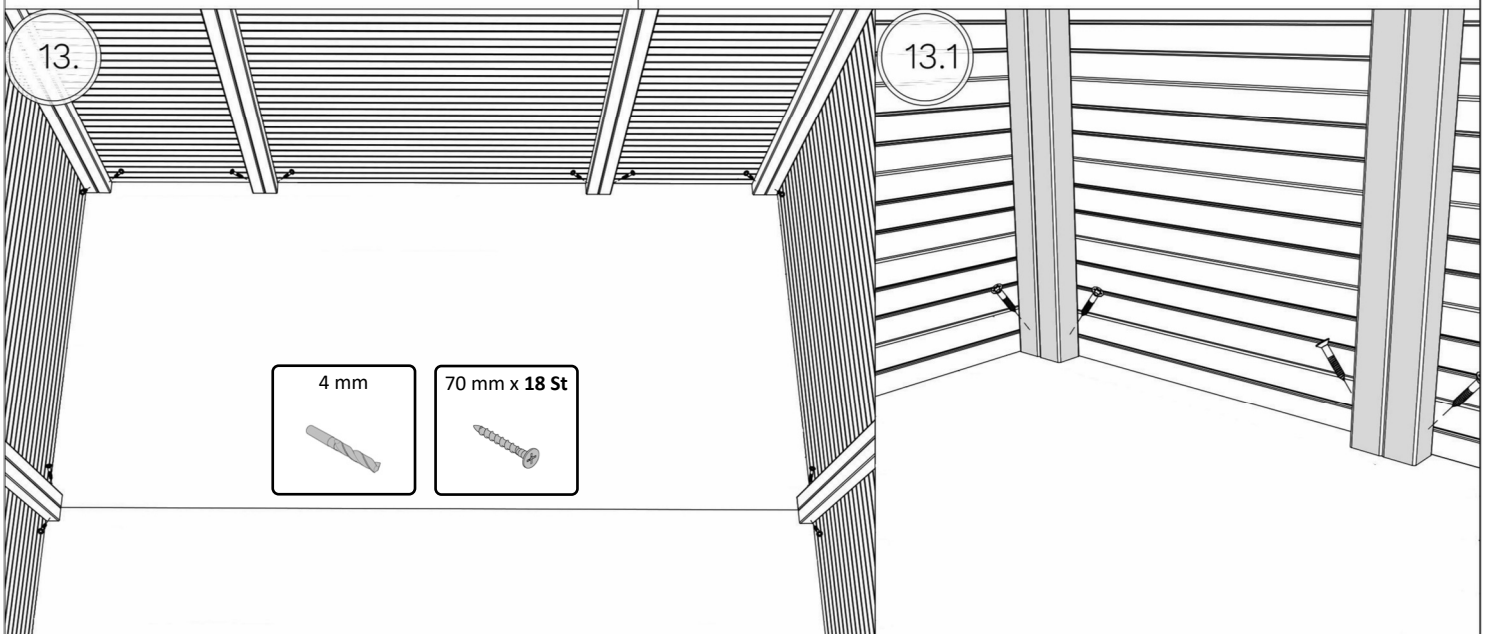

BCON1(NF/AN)

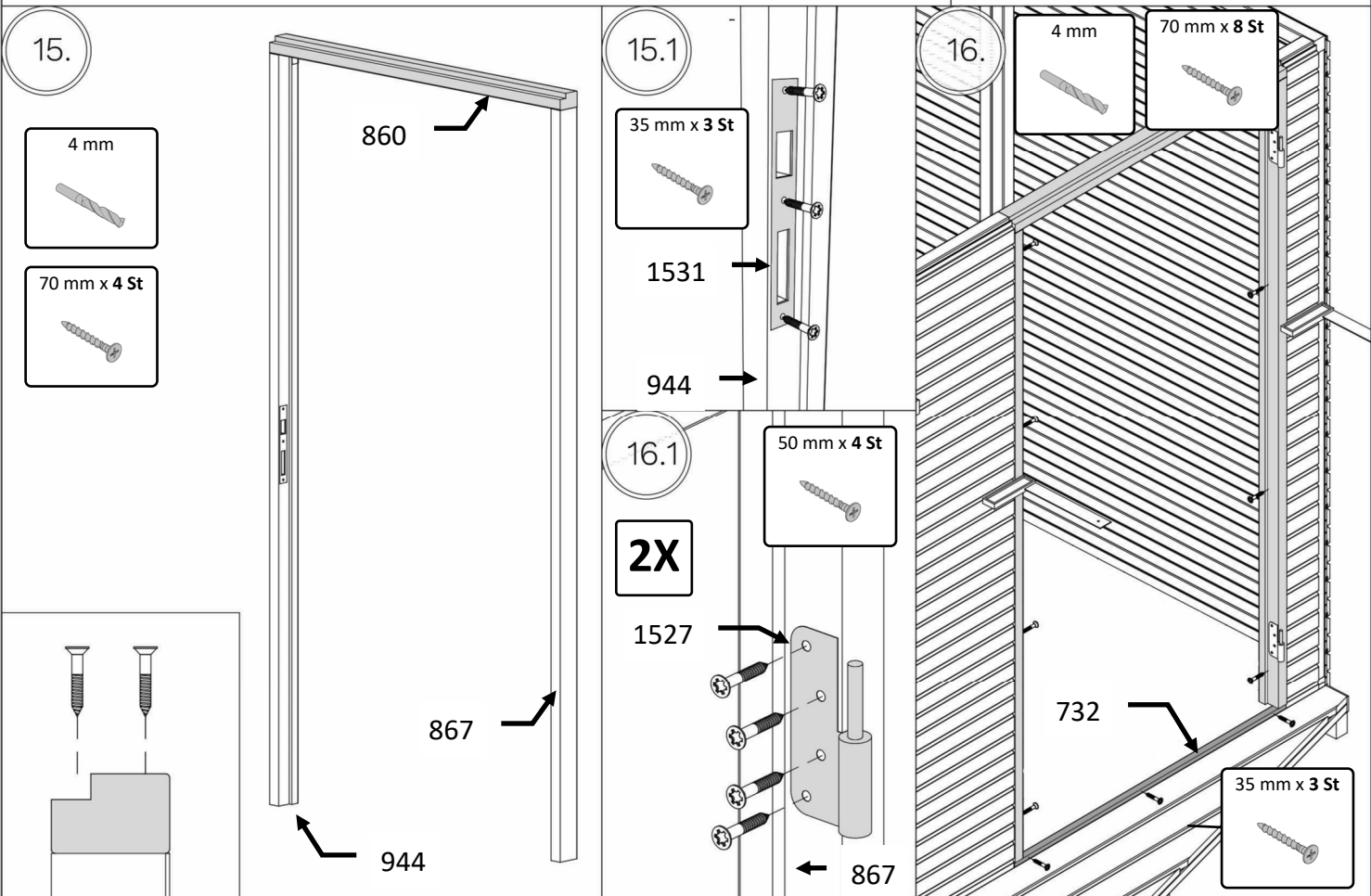
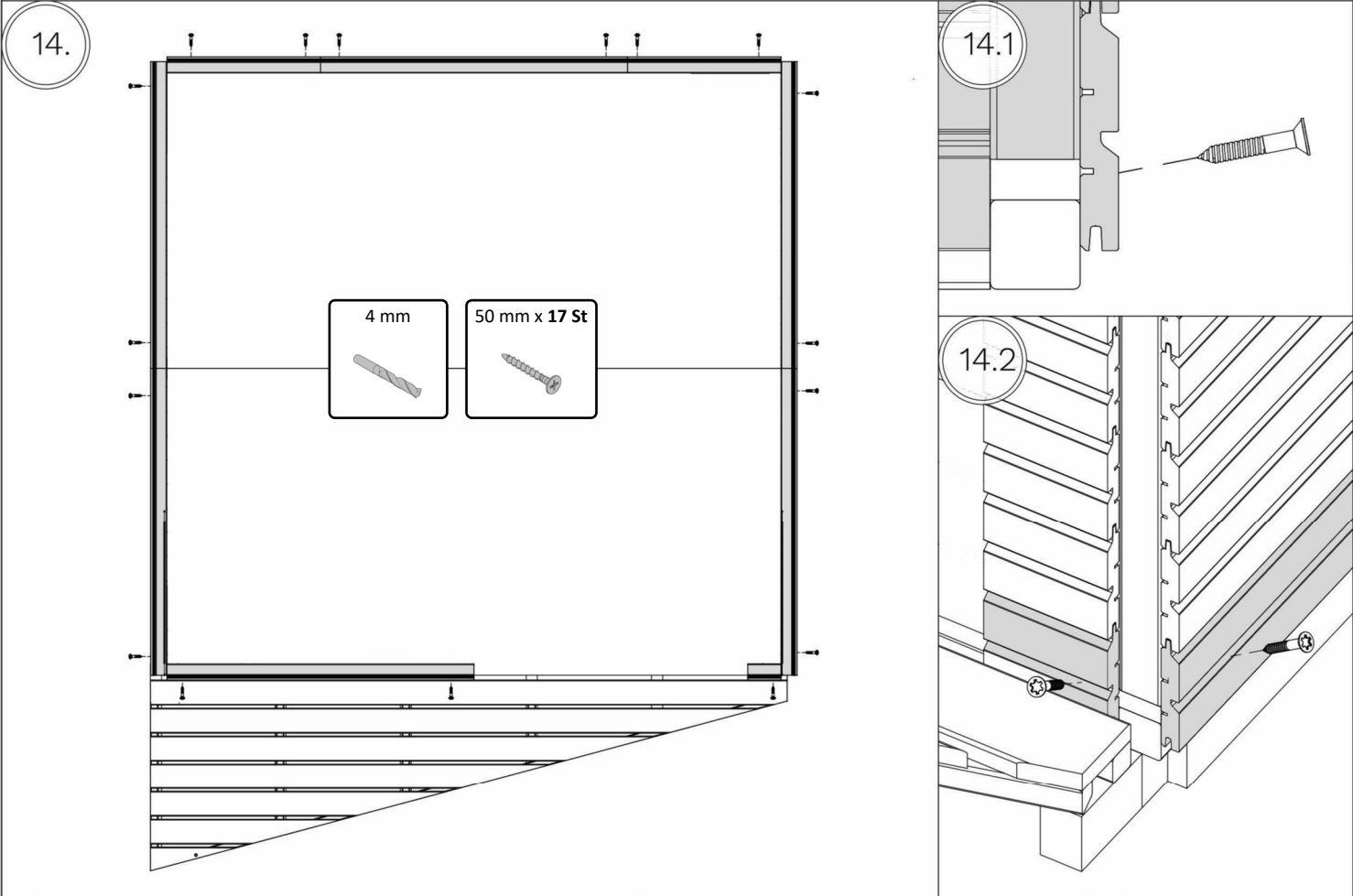

BCON1(NF/AN)

17.

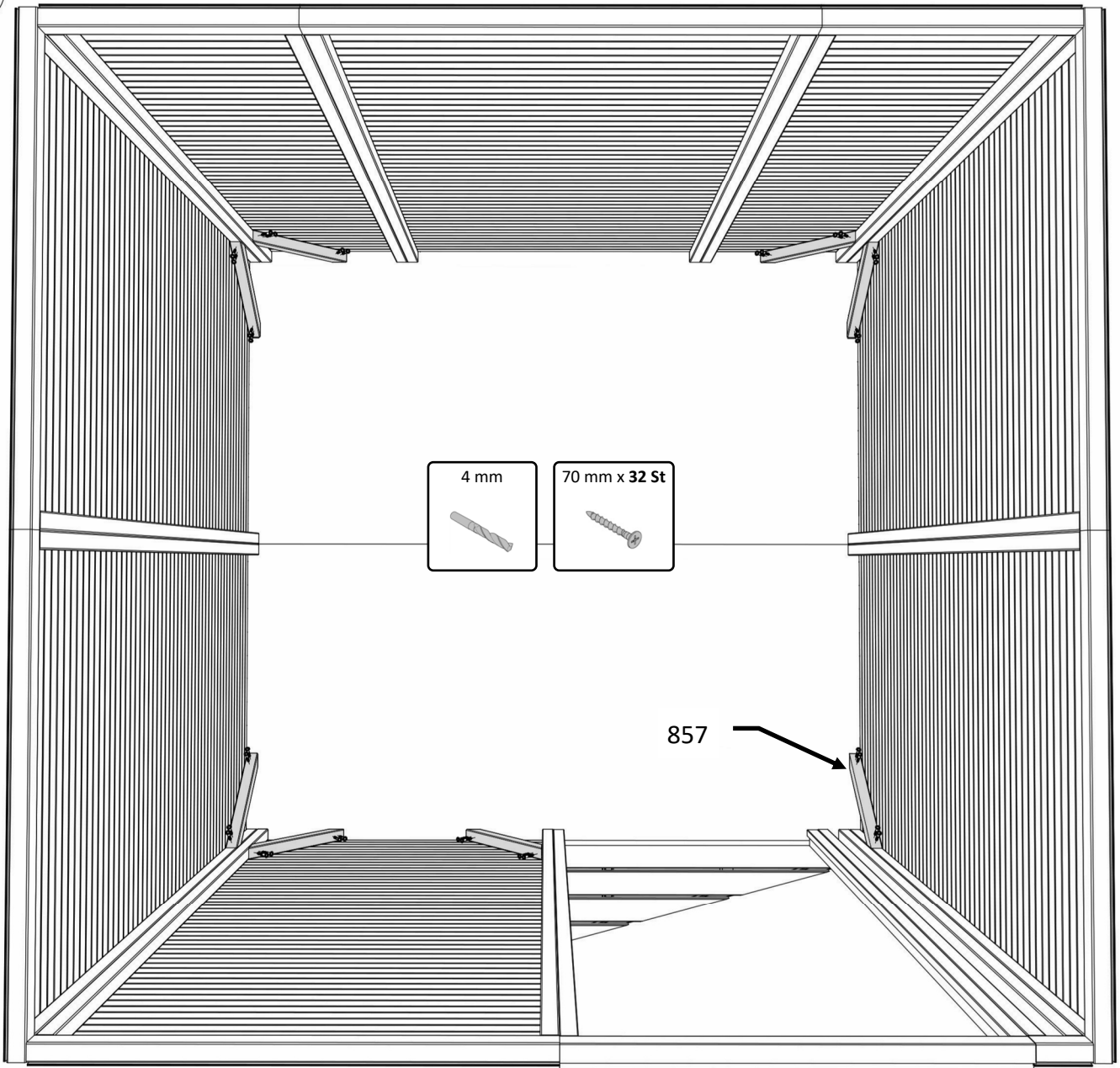

17.1

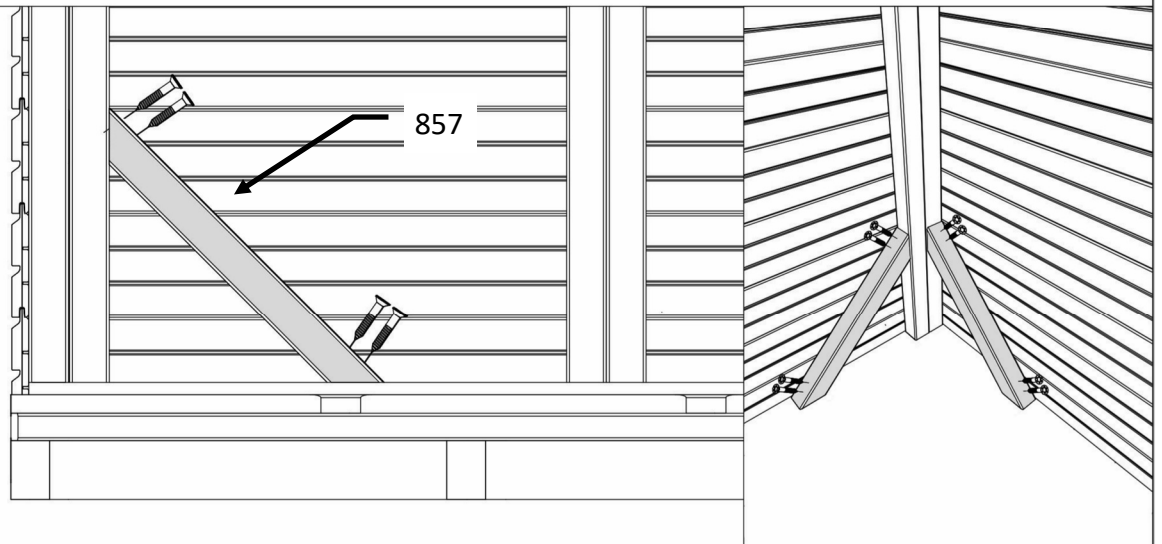

BCON1(NF/AN)

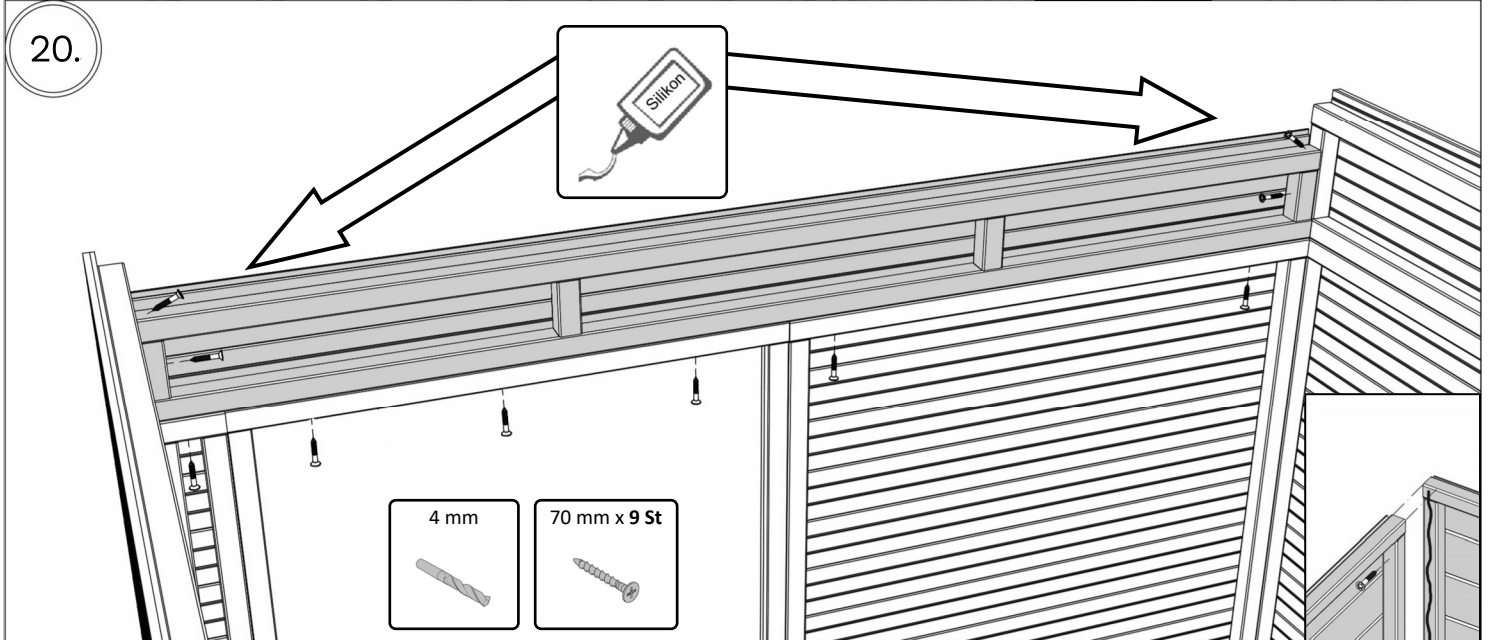
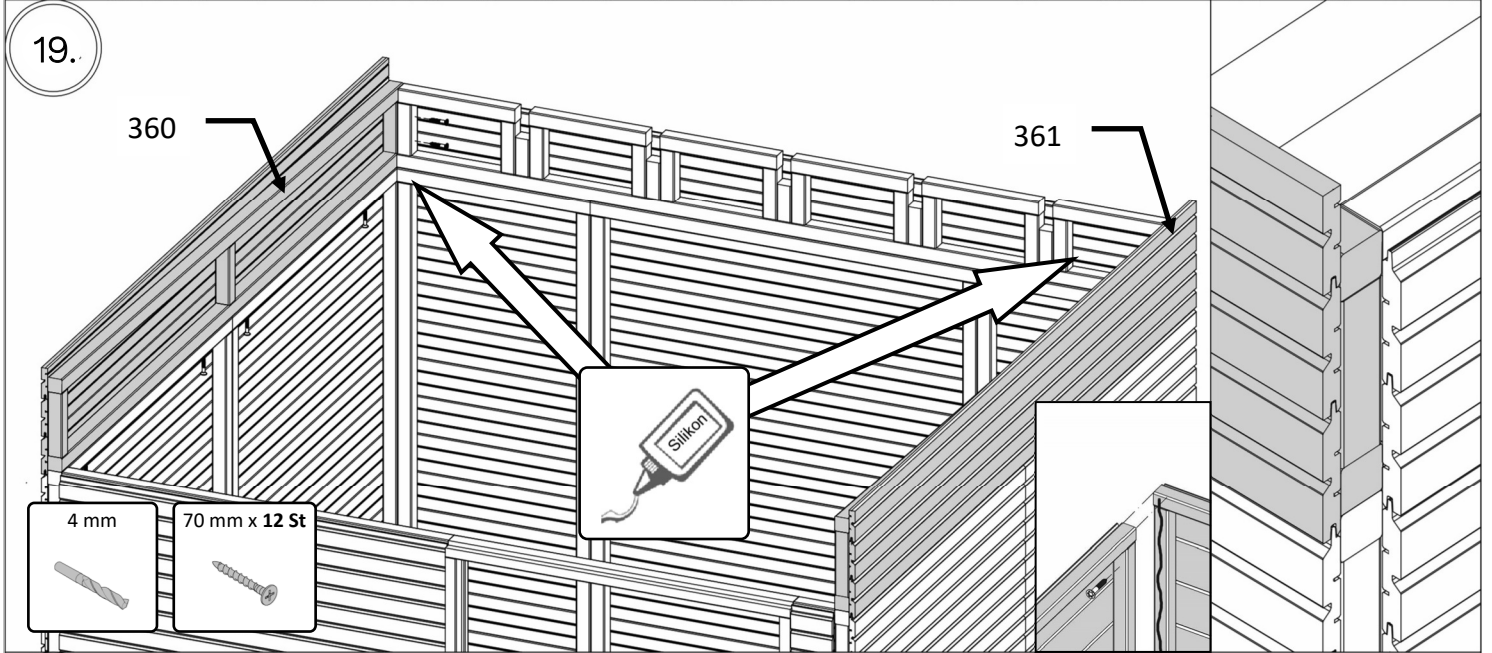
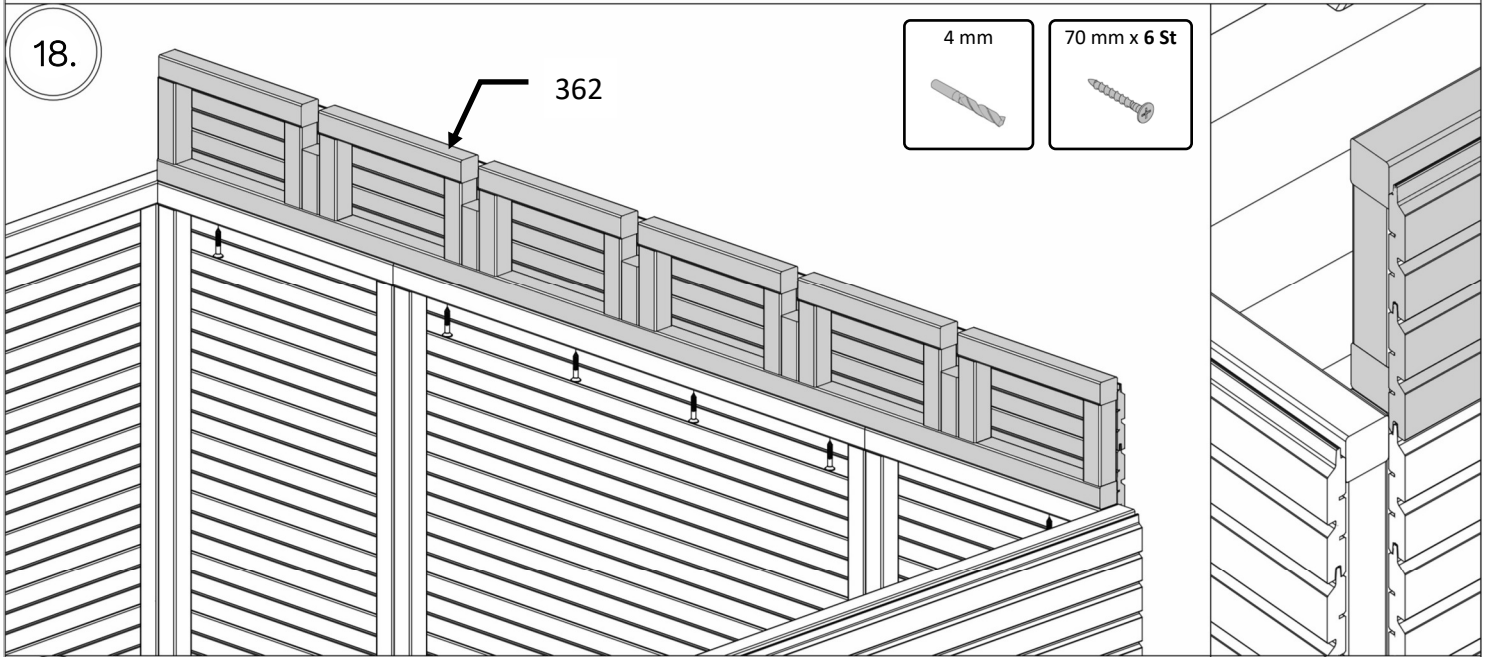

BCON1(NF/AN)

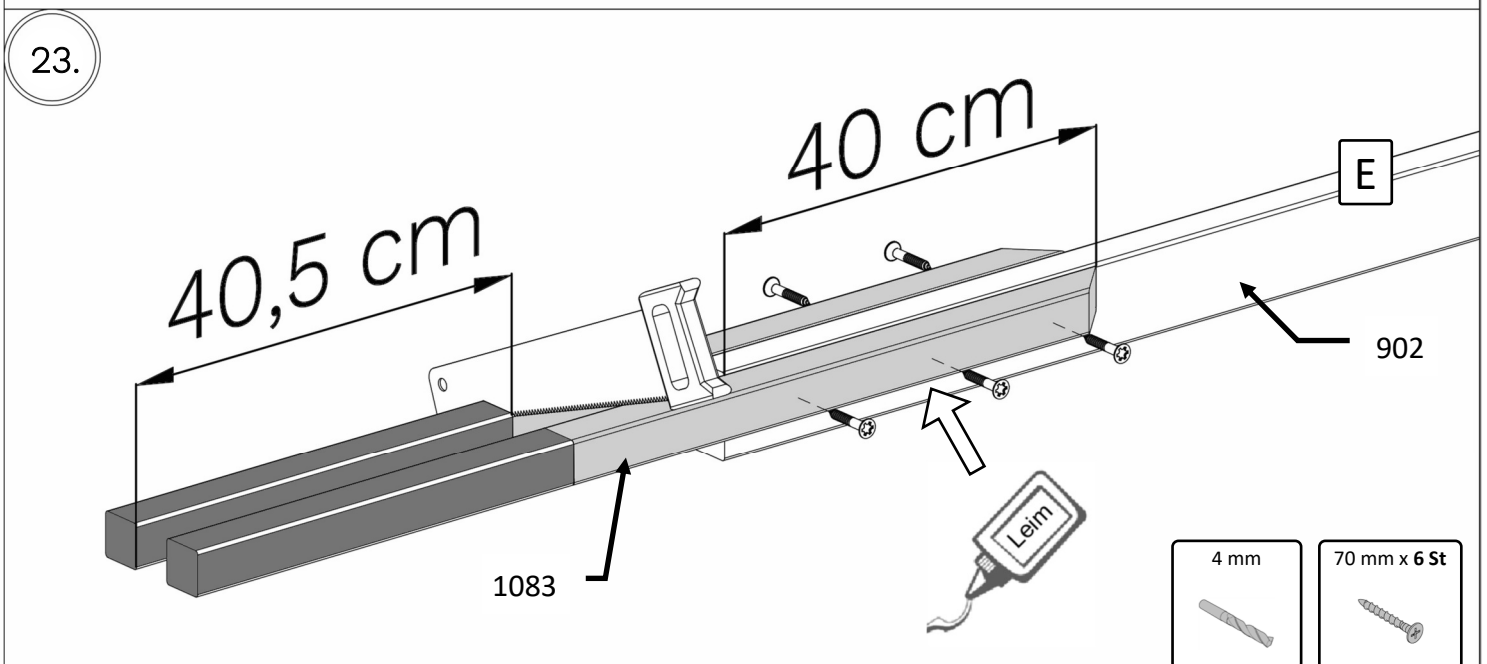
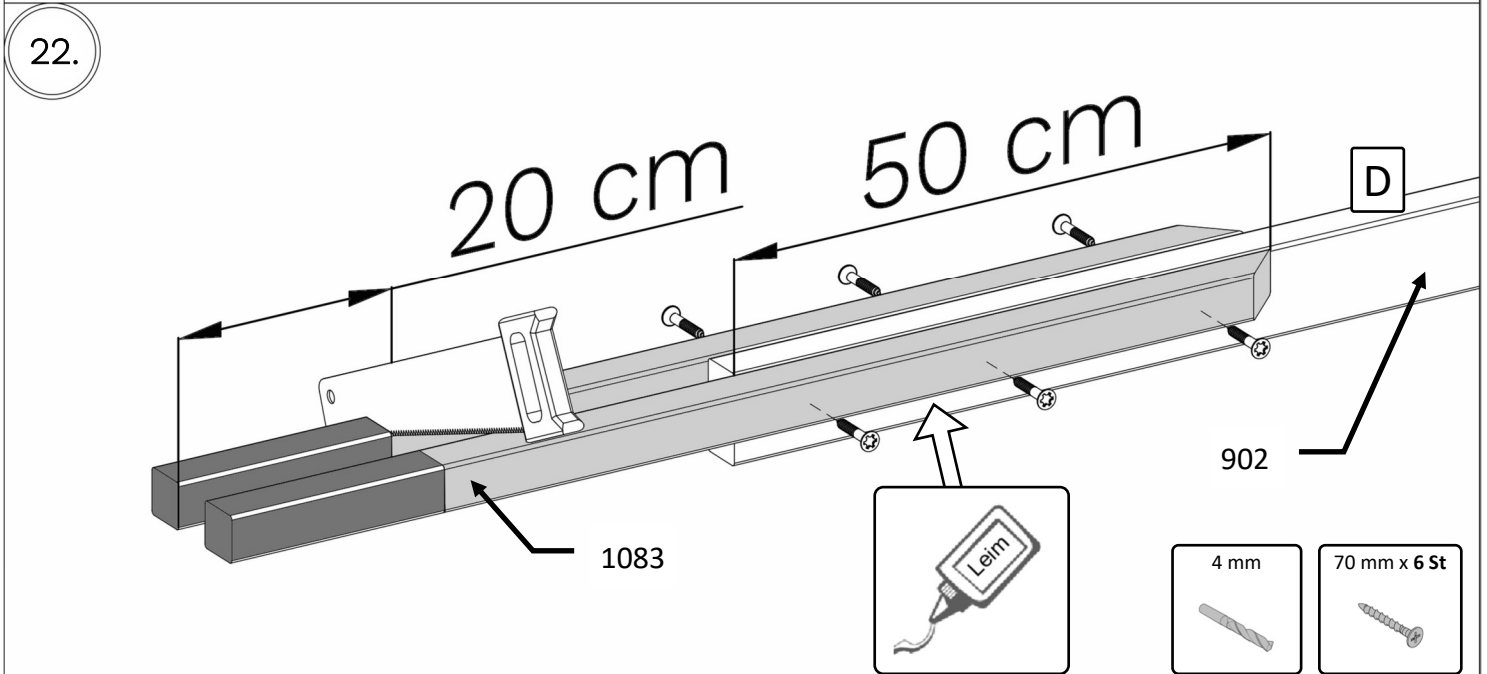
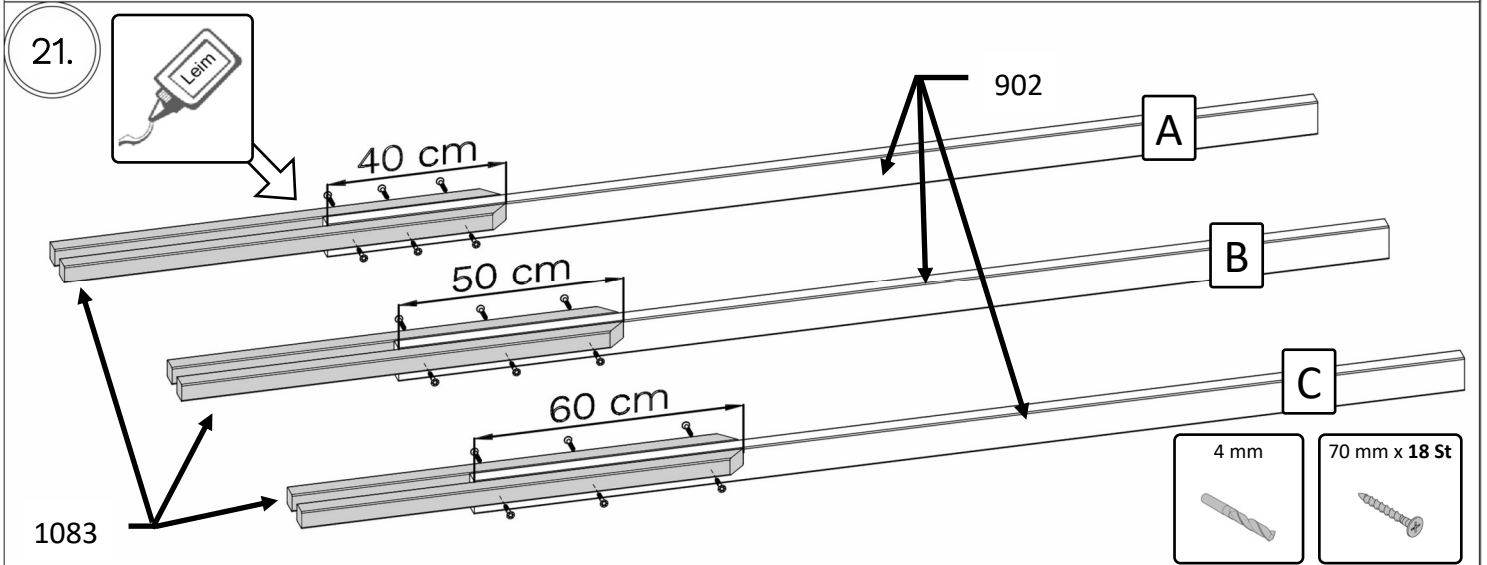

BCON1(NF/AN)

24.

4 mm

70 mm x 10 St

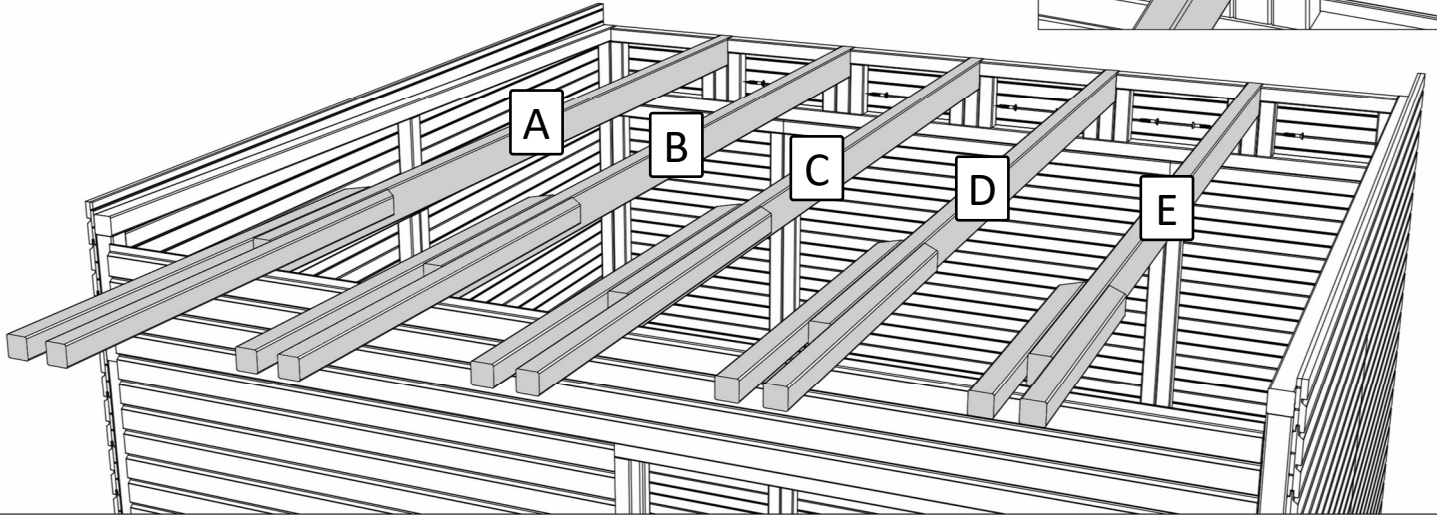
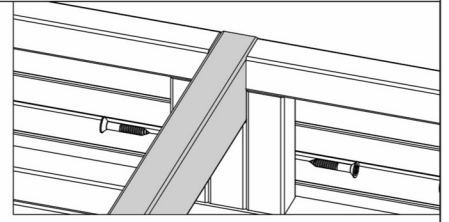

336

336

336

336

336

336

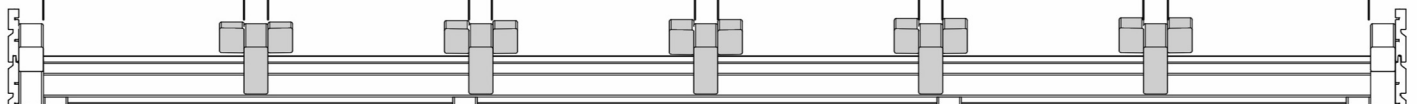

25.

4 mm



120 mm x 5 St

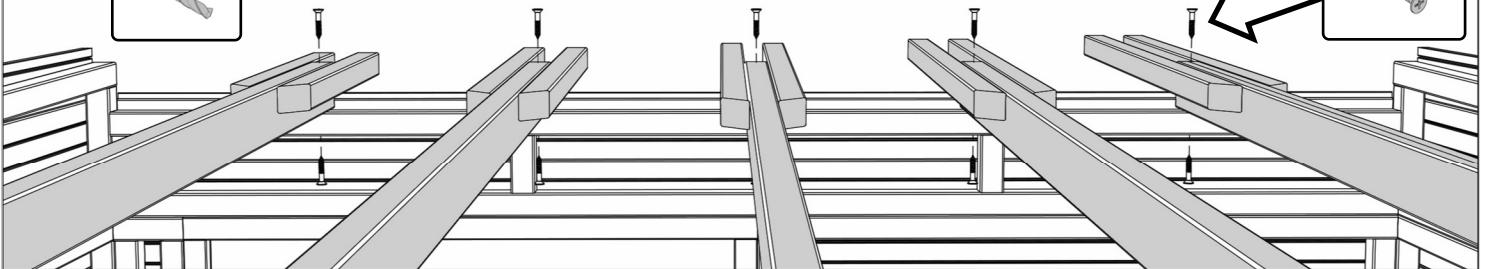

26.

4 mm

70 mm x 5 St

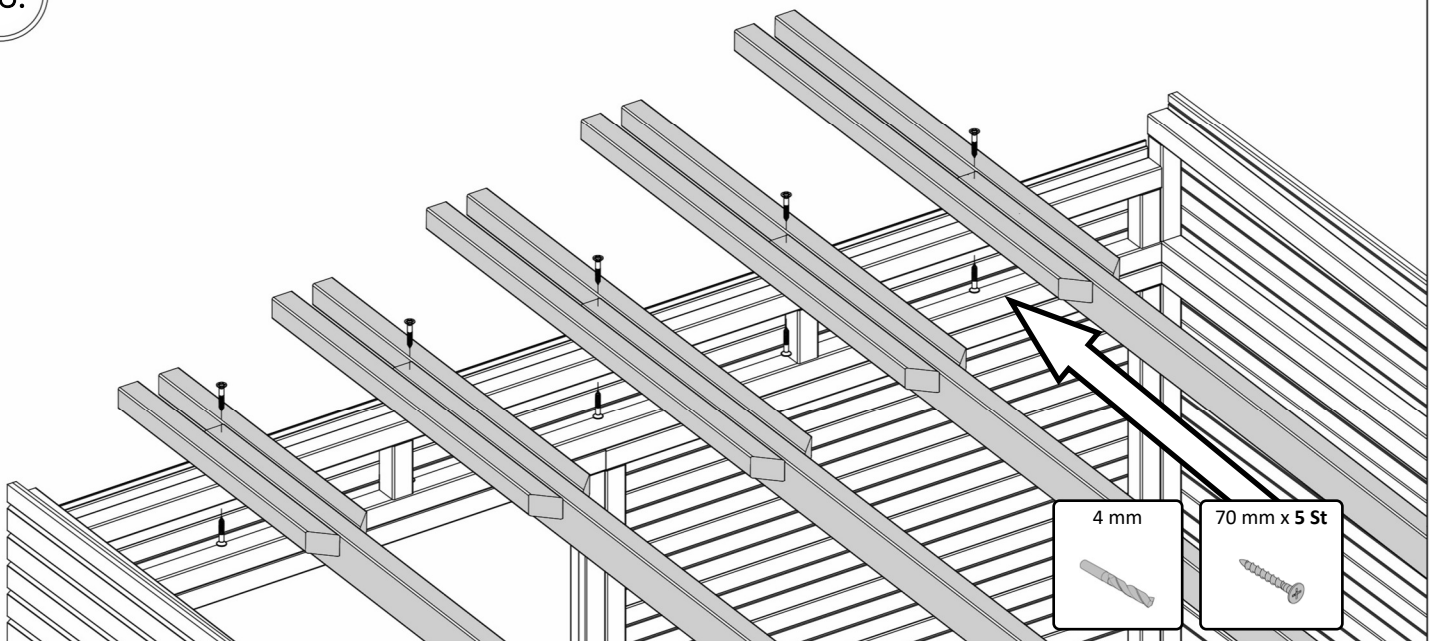

B CON1(NF/AN)

27.

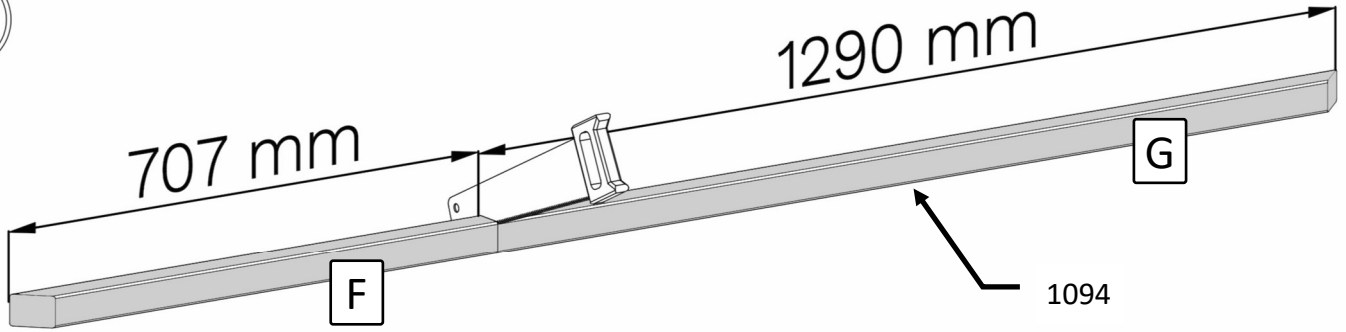

28.

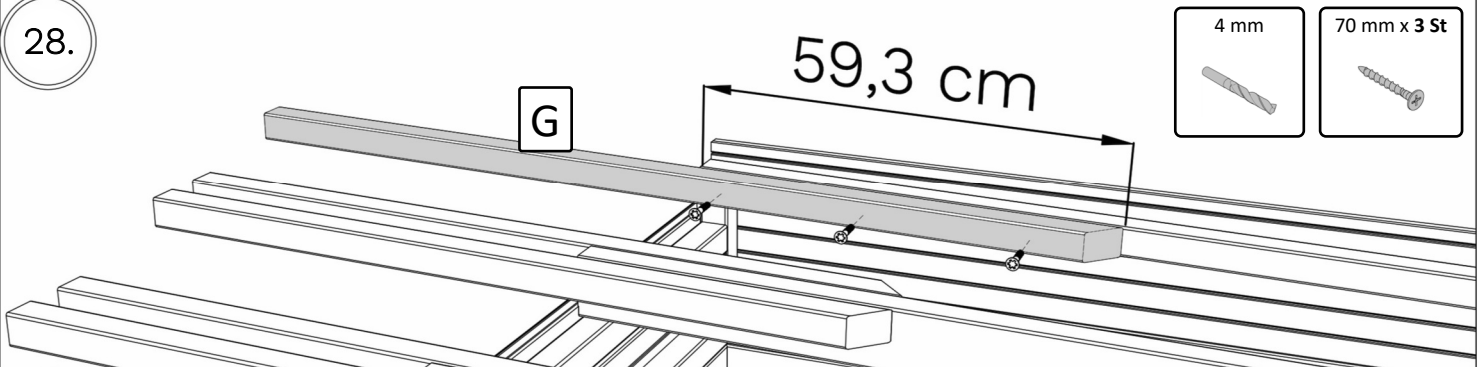

29.

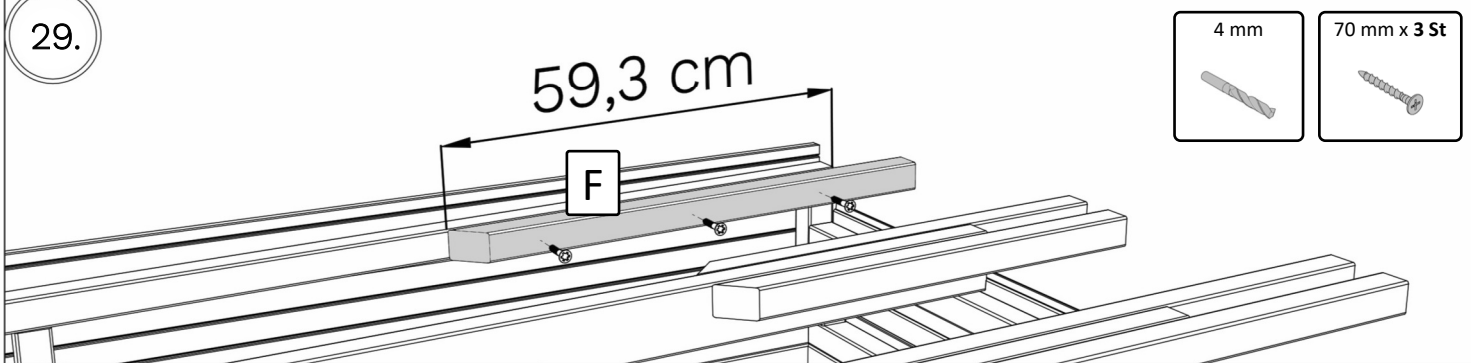

30.

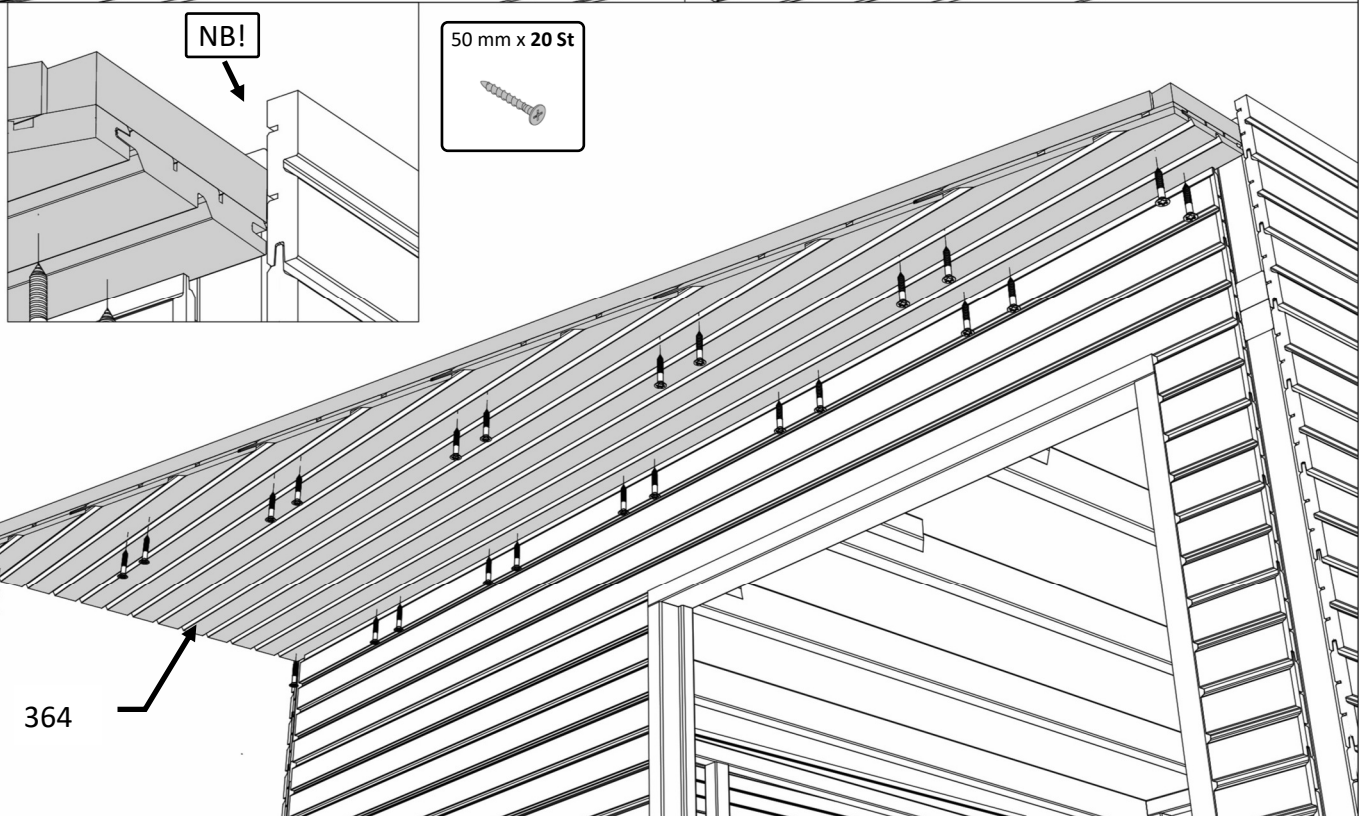

BCON1(NF/AN)

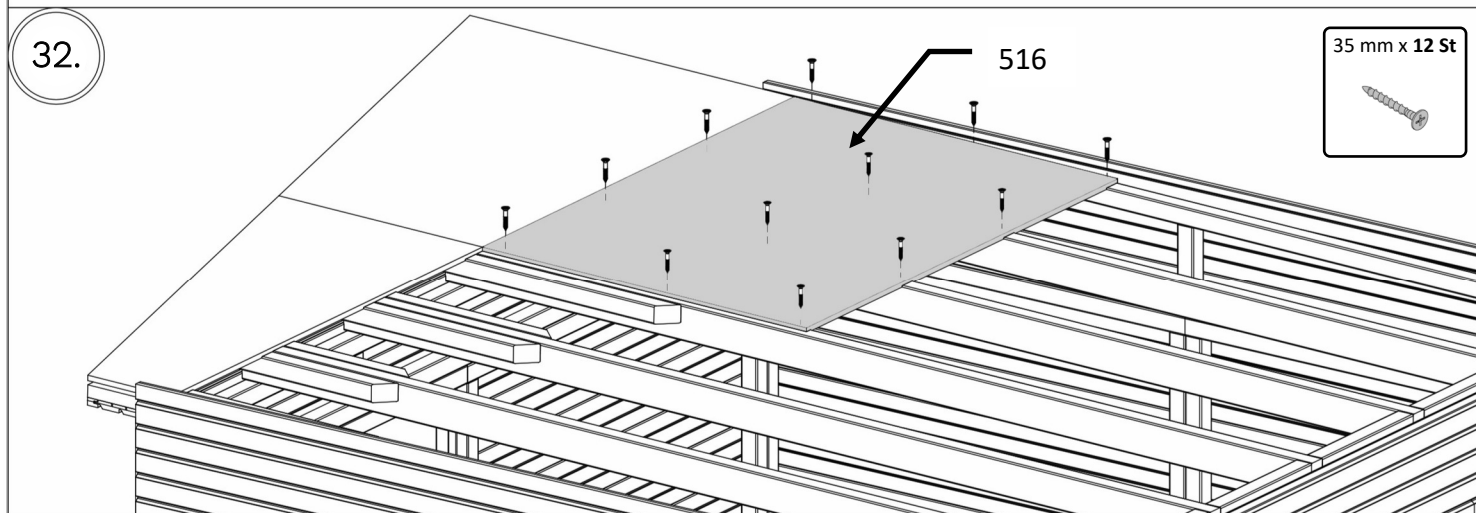
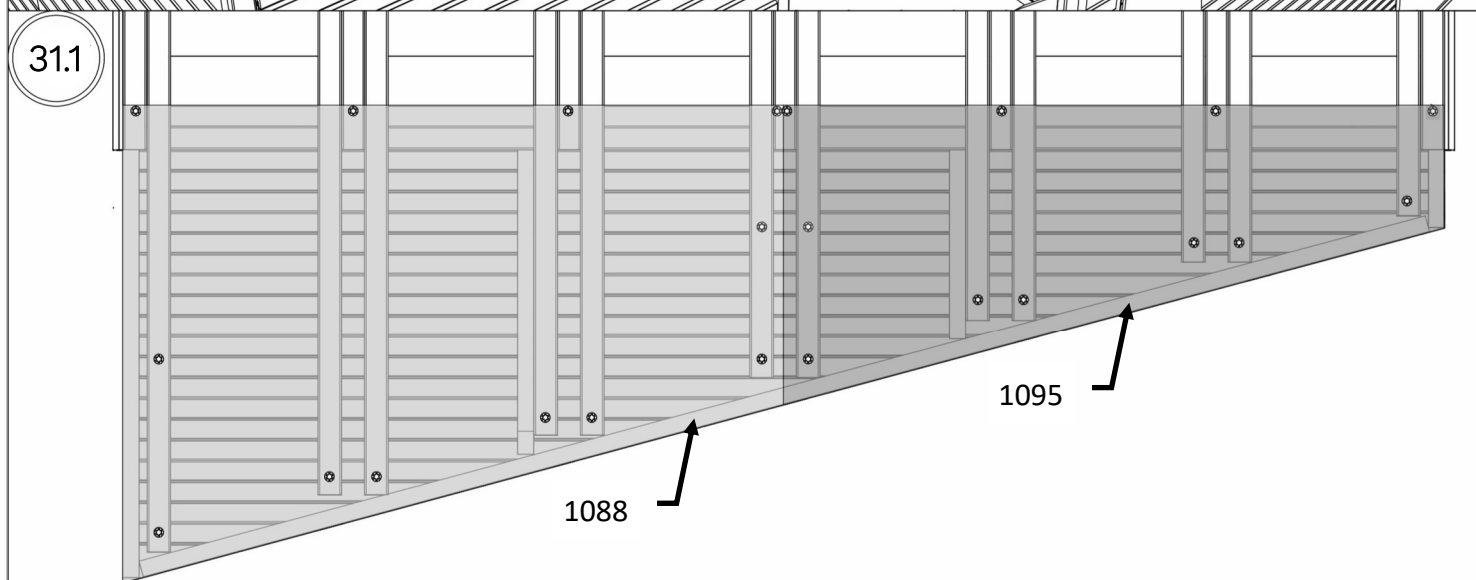
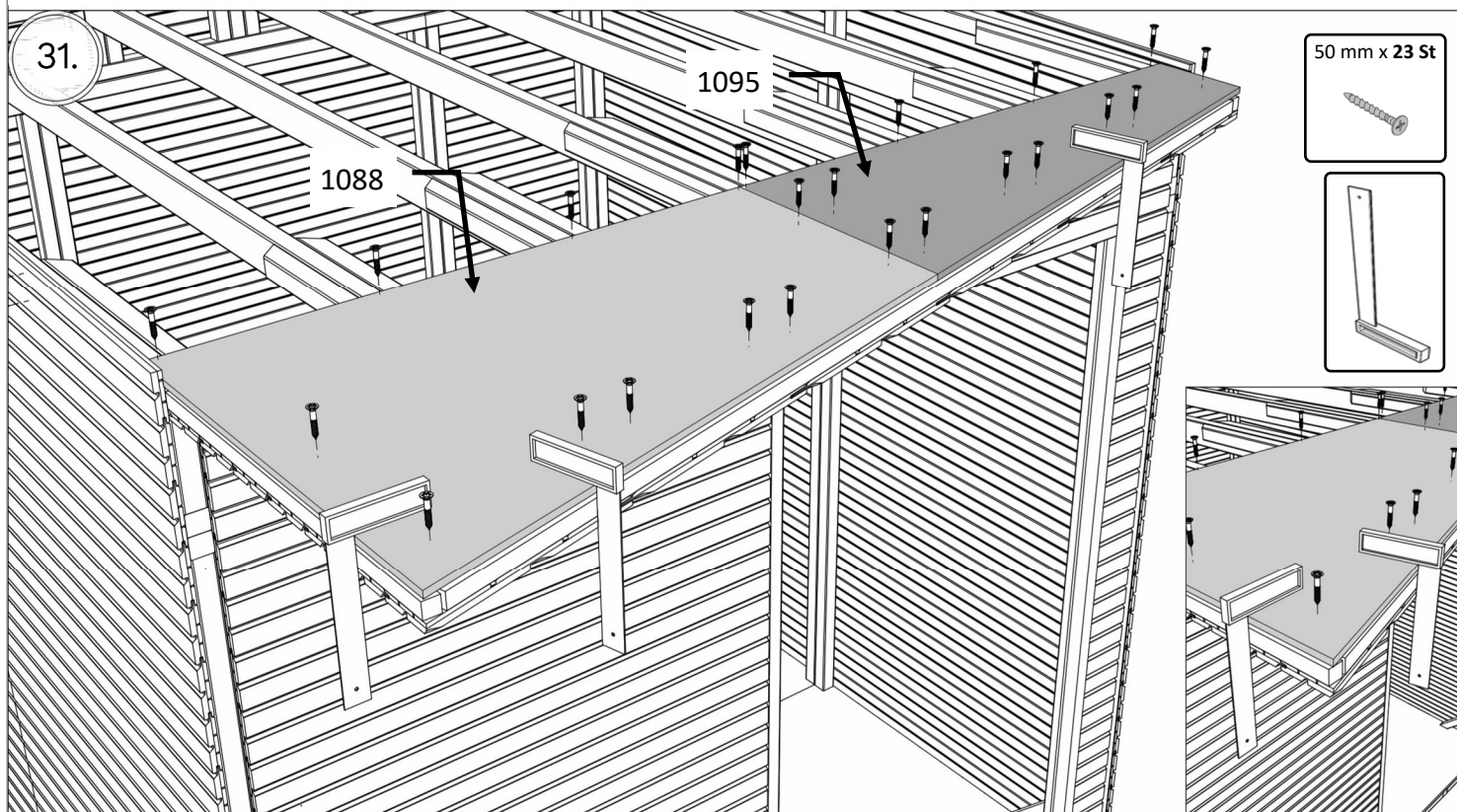

BCON1(NF/AN)

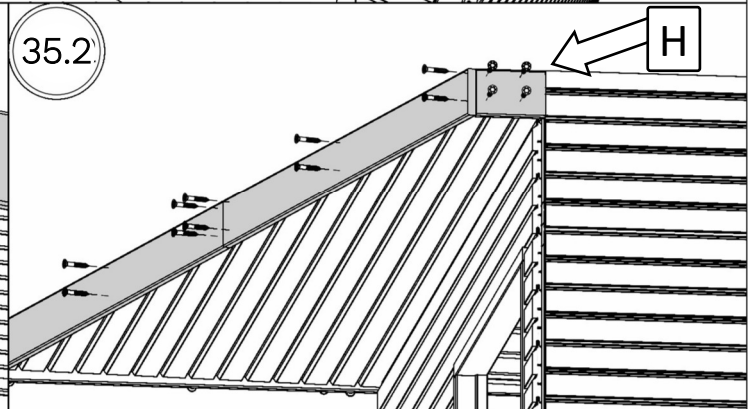
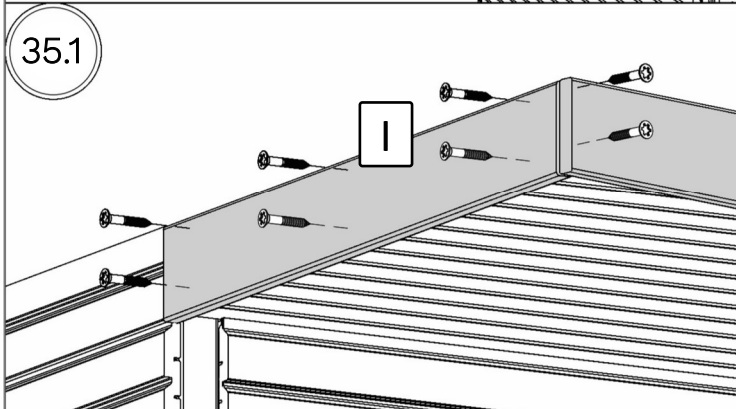
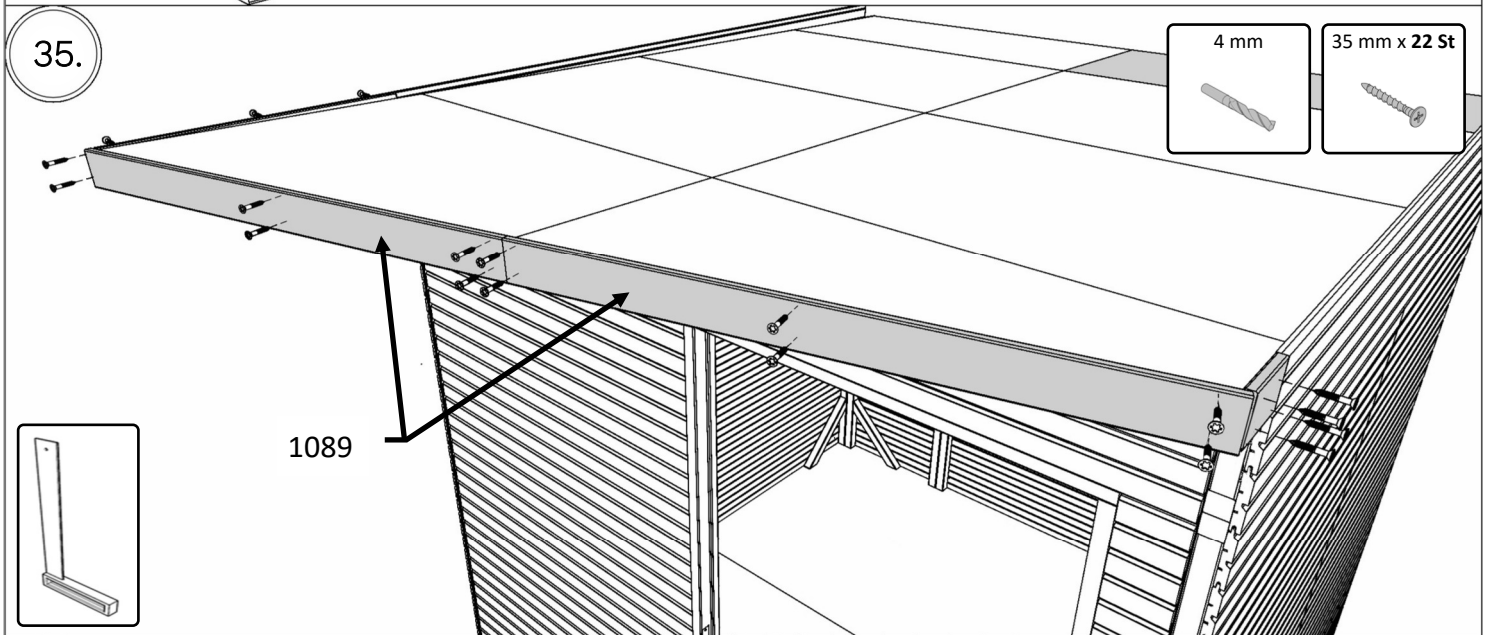
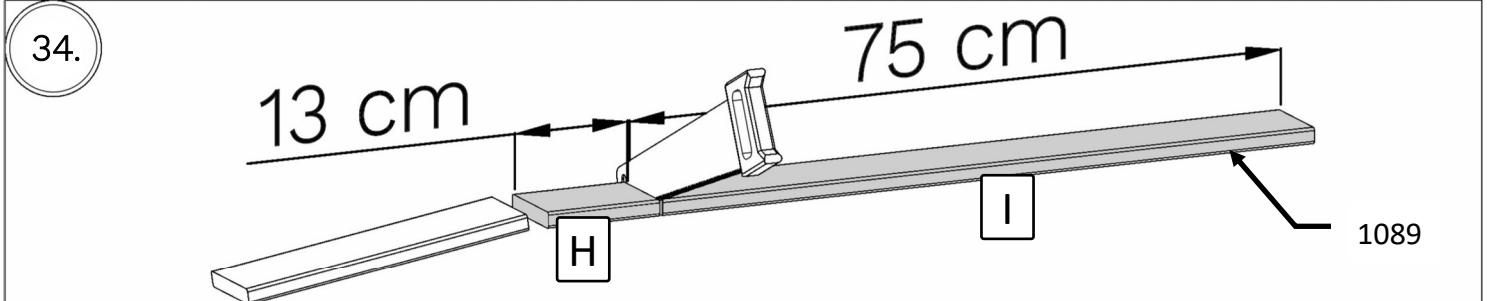
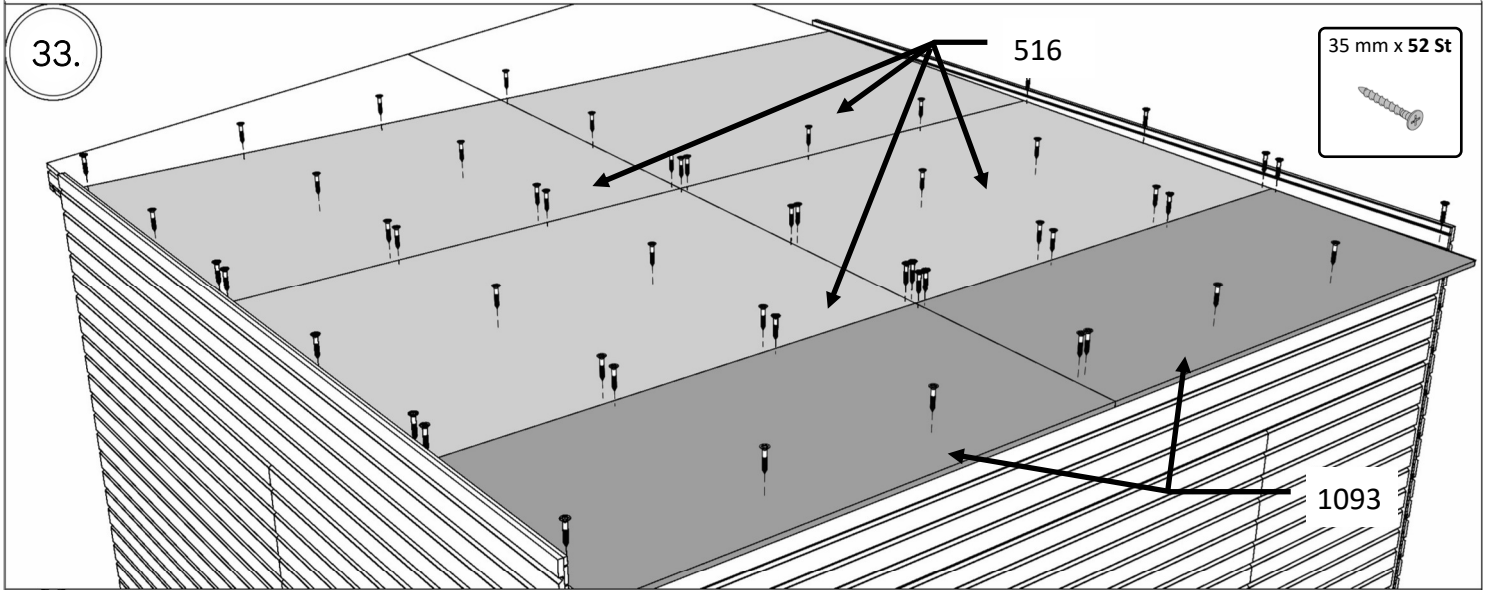

BCON1(NF/AN)

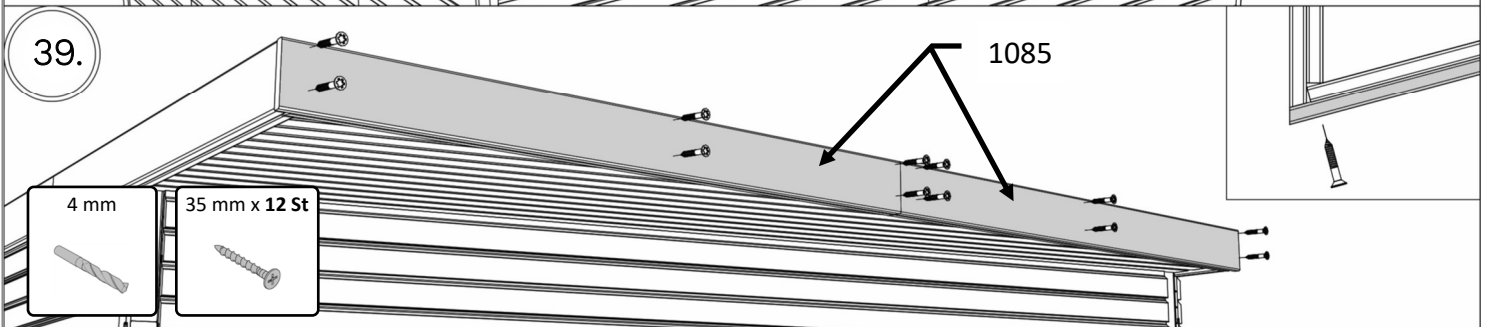
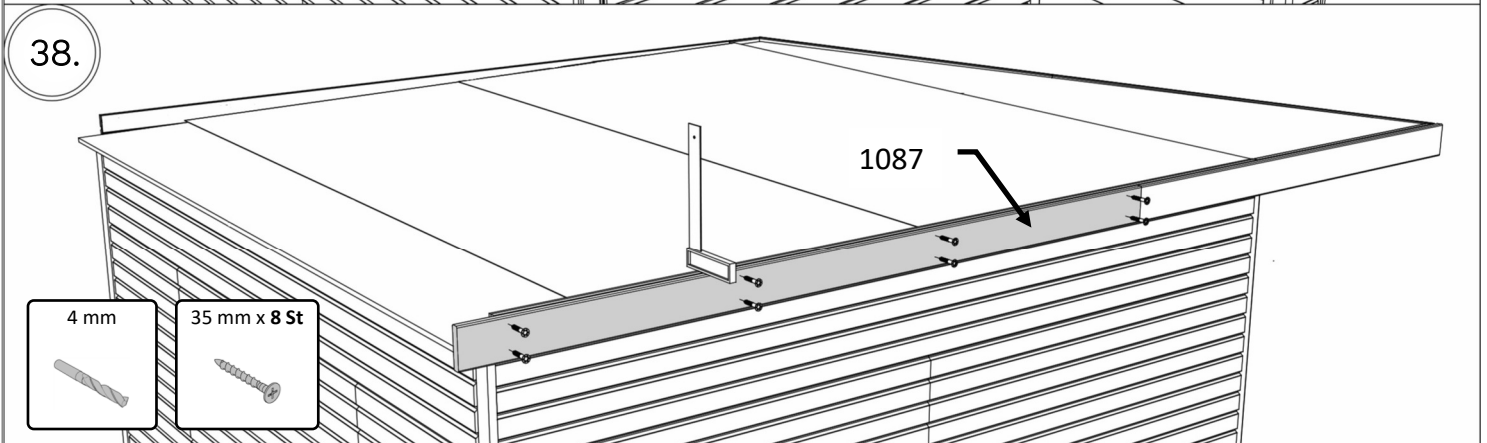
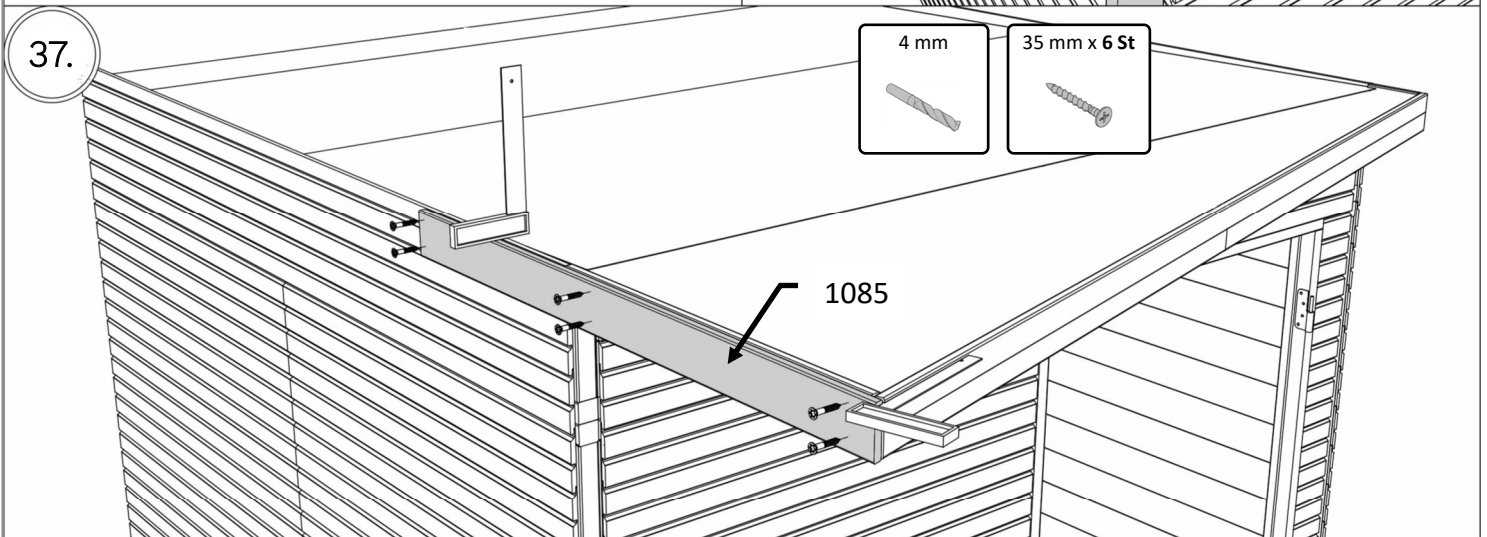
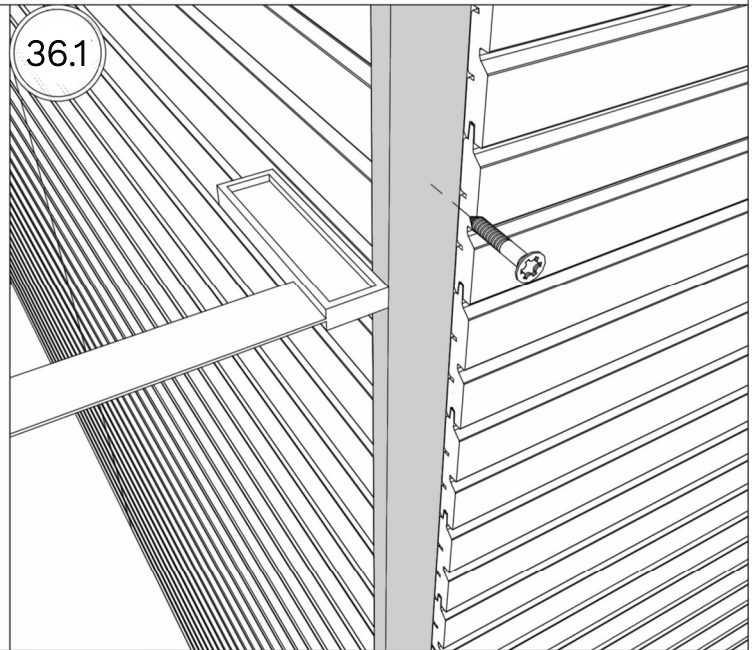
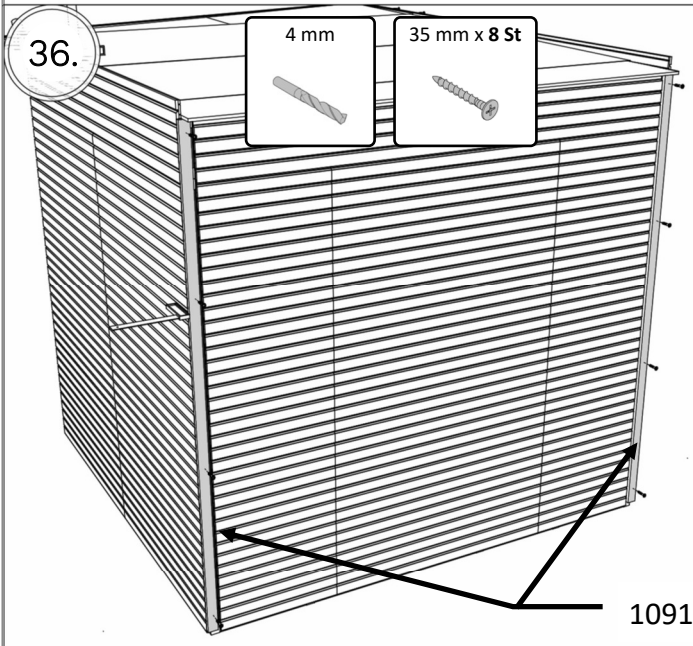

BCON1(NF/AN)

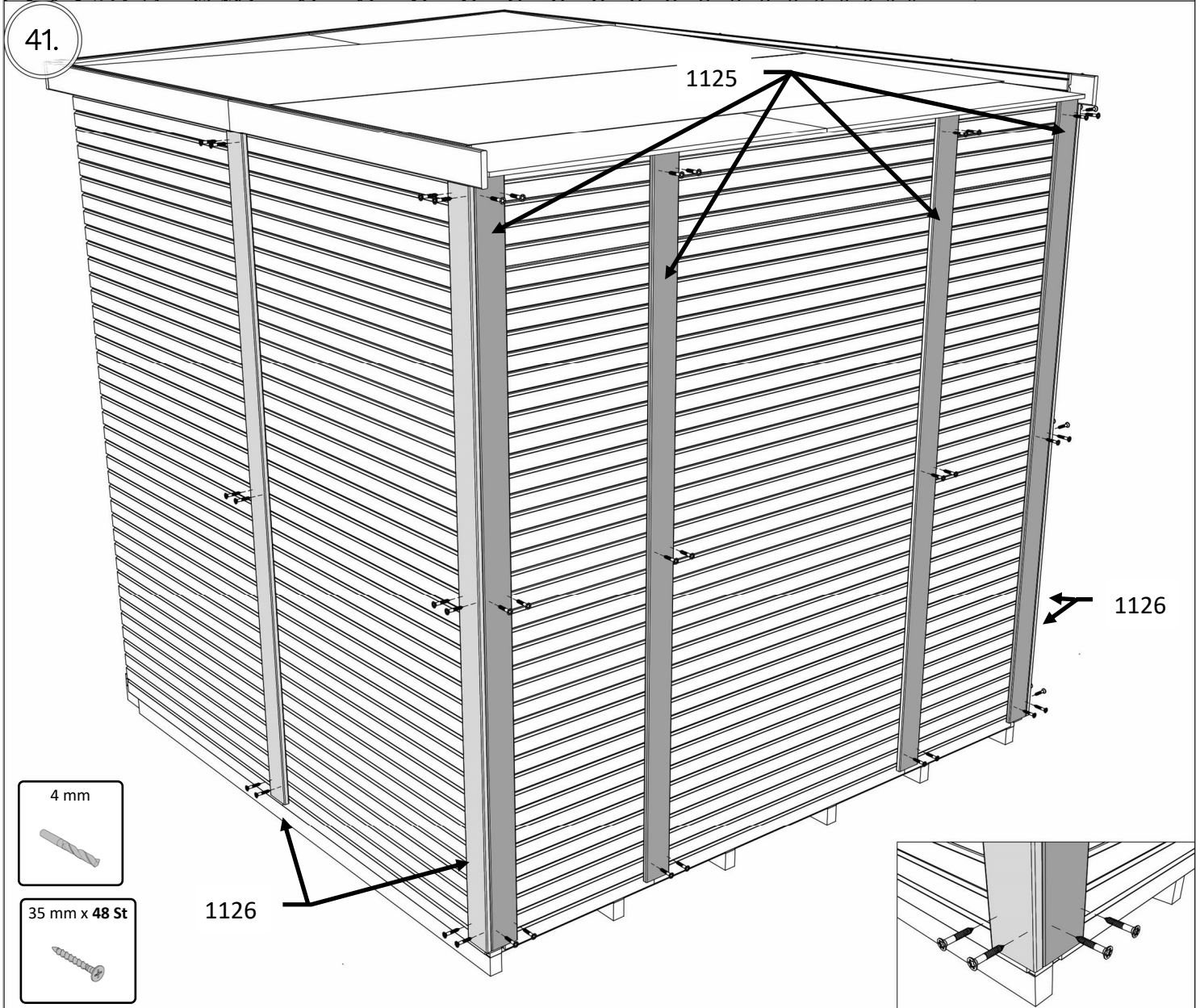
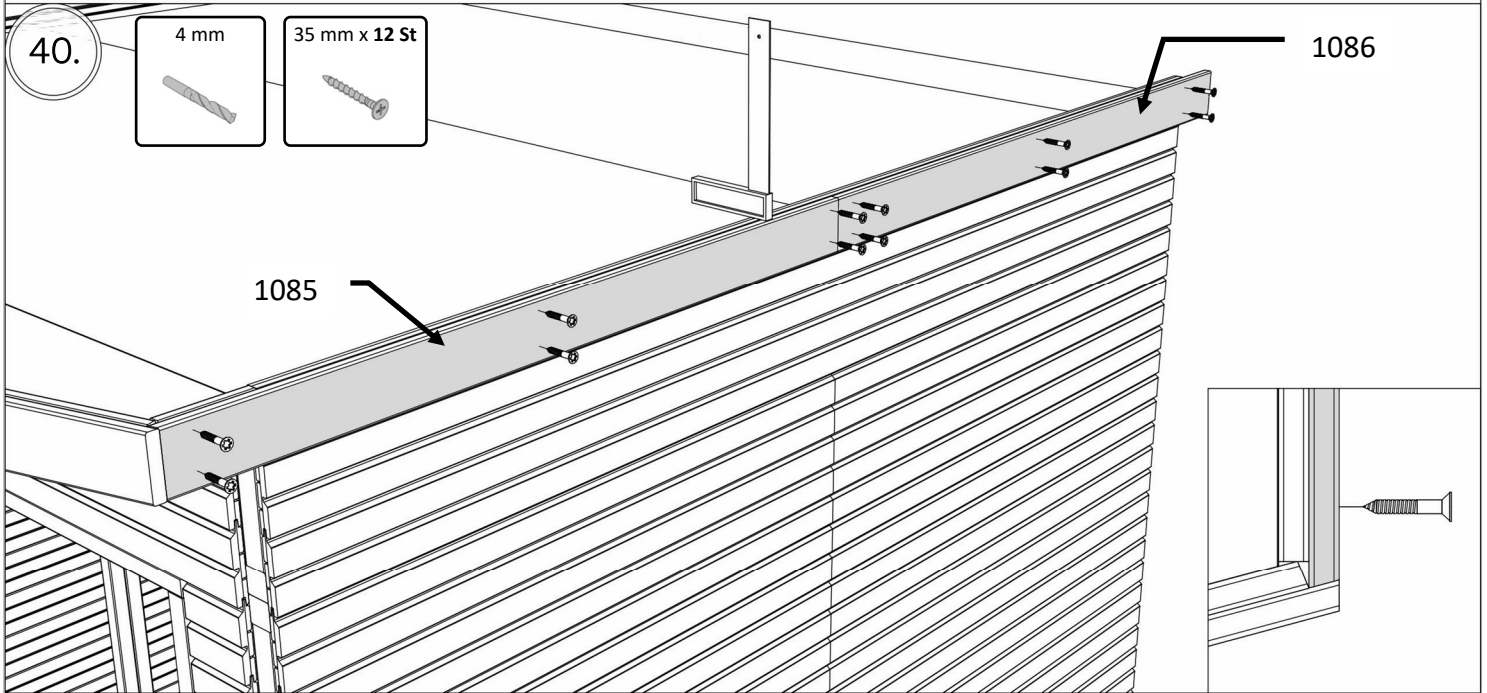

BCON1(NF/AN)

42.

4 mm



50 mm x 8 St



1098

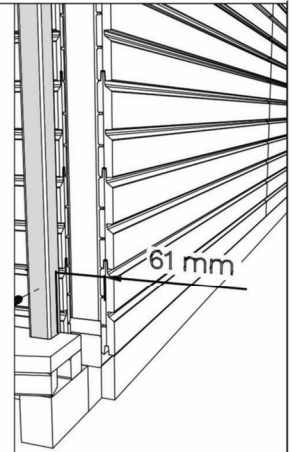
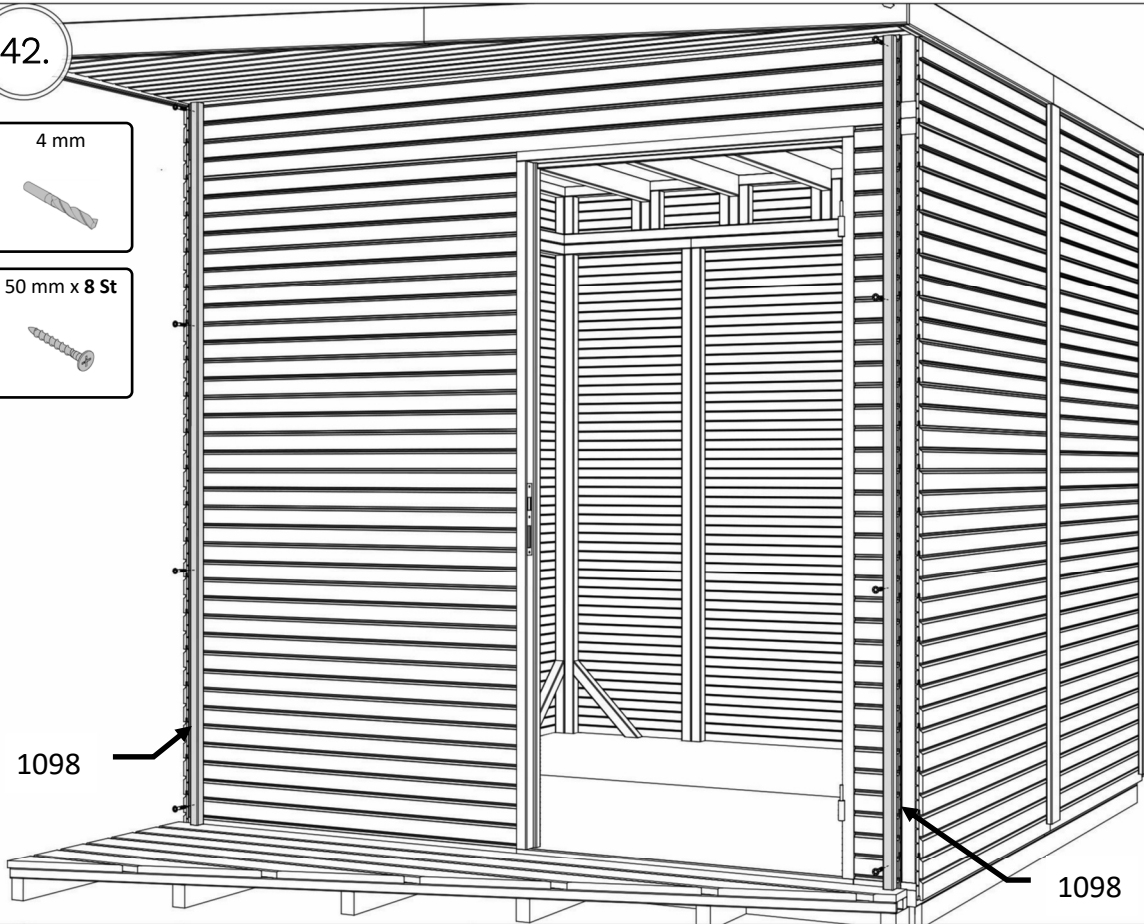

61 mm

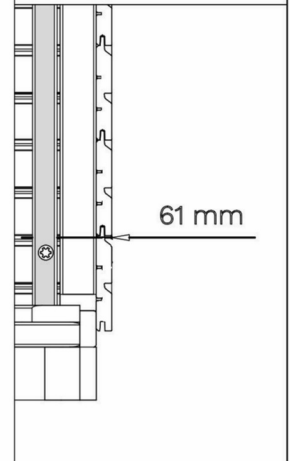

61 mm

43.

2x

4 mm



35 mm x 20 St

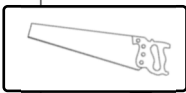
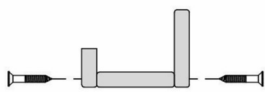

1126

1091

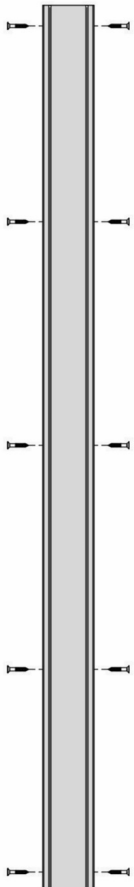

44.

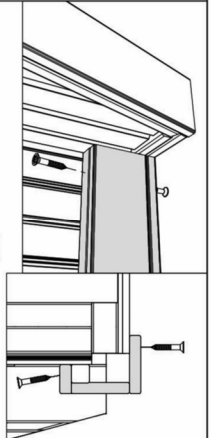
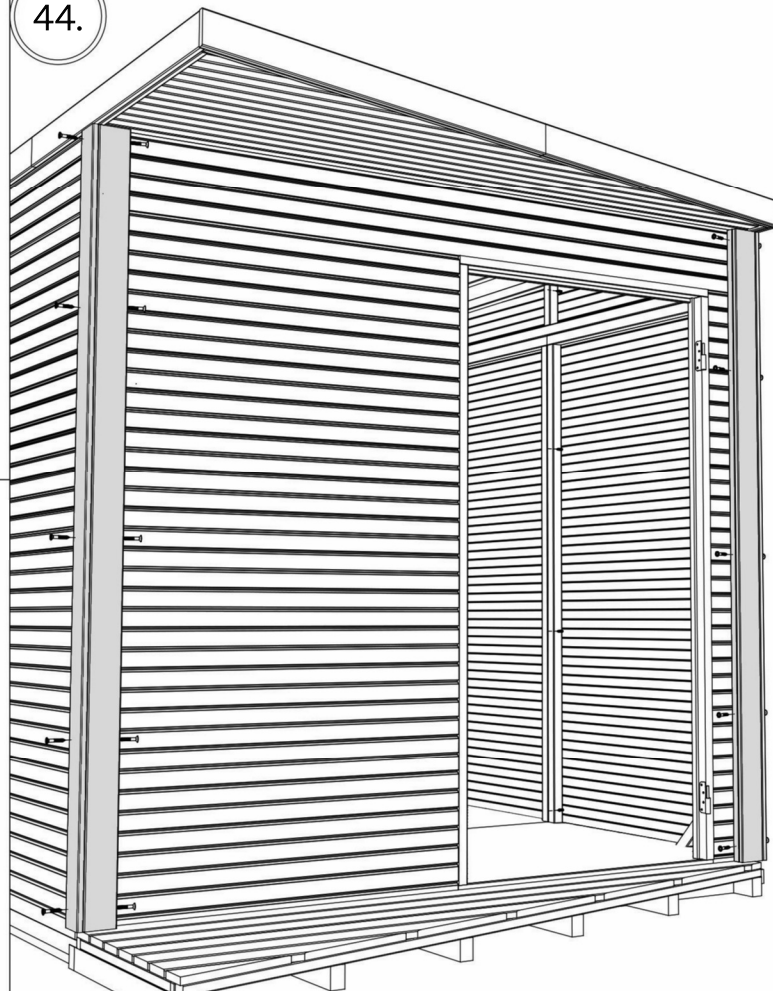

4 mm



35 mm x 20 St



BCON1(NF/AN)

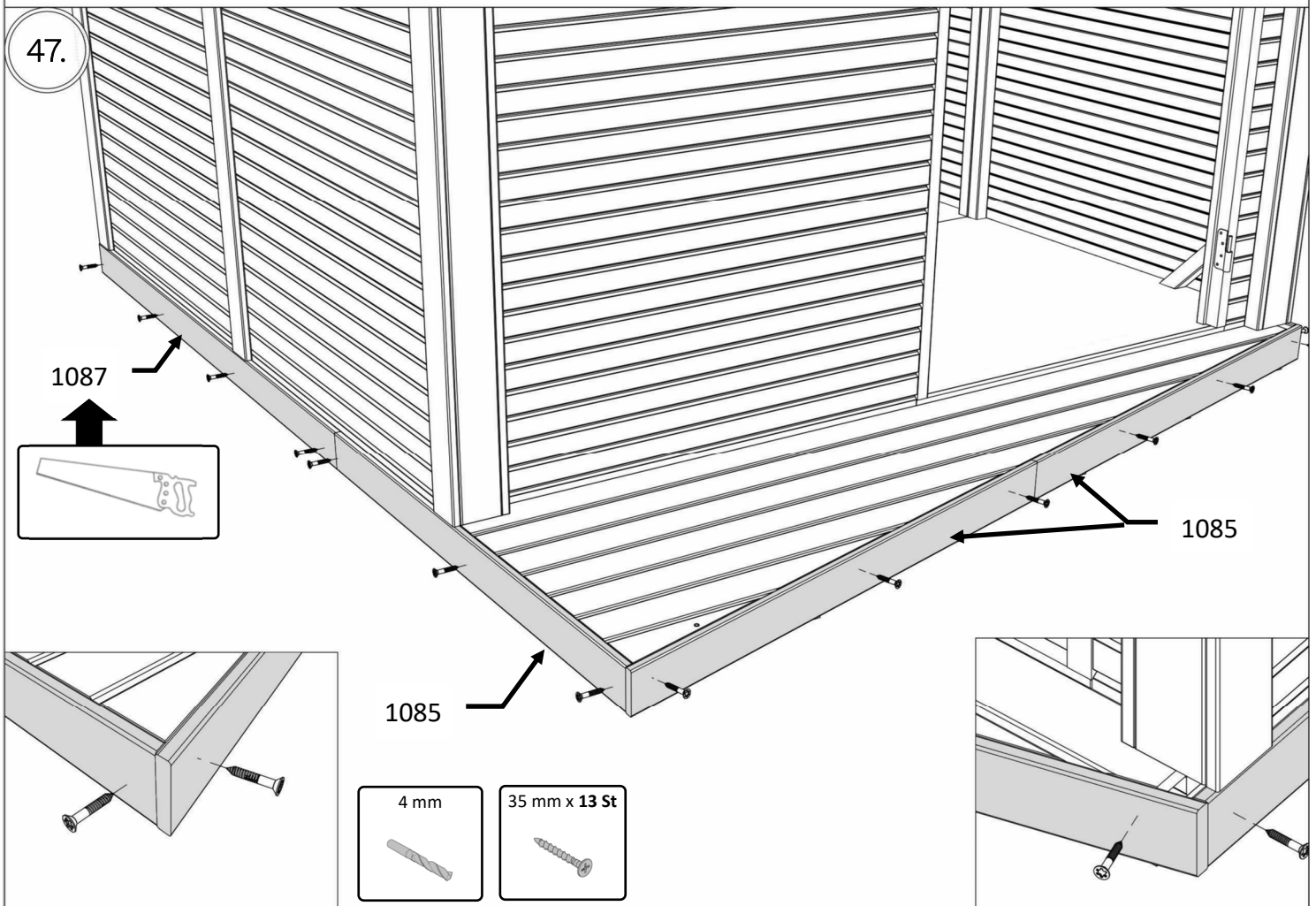
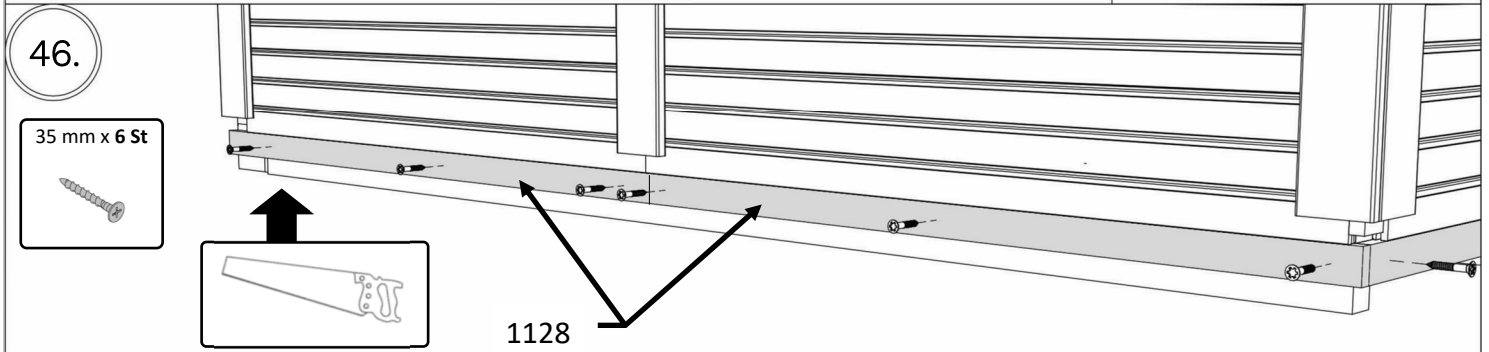
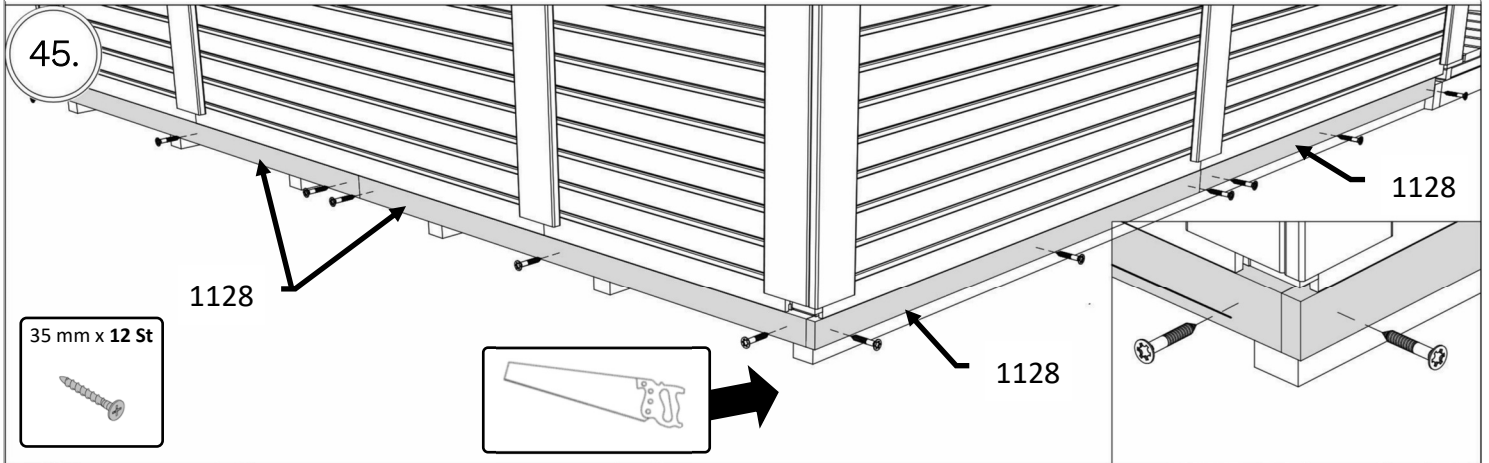

BCON1(NF/AN)

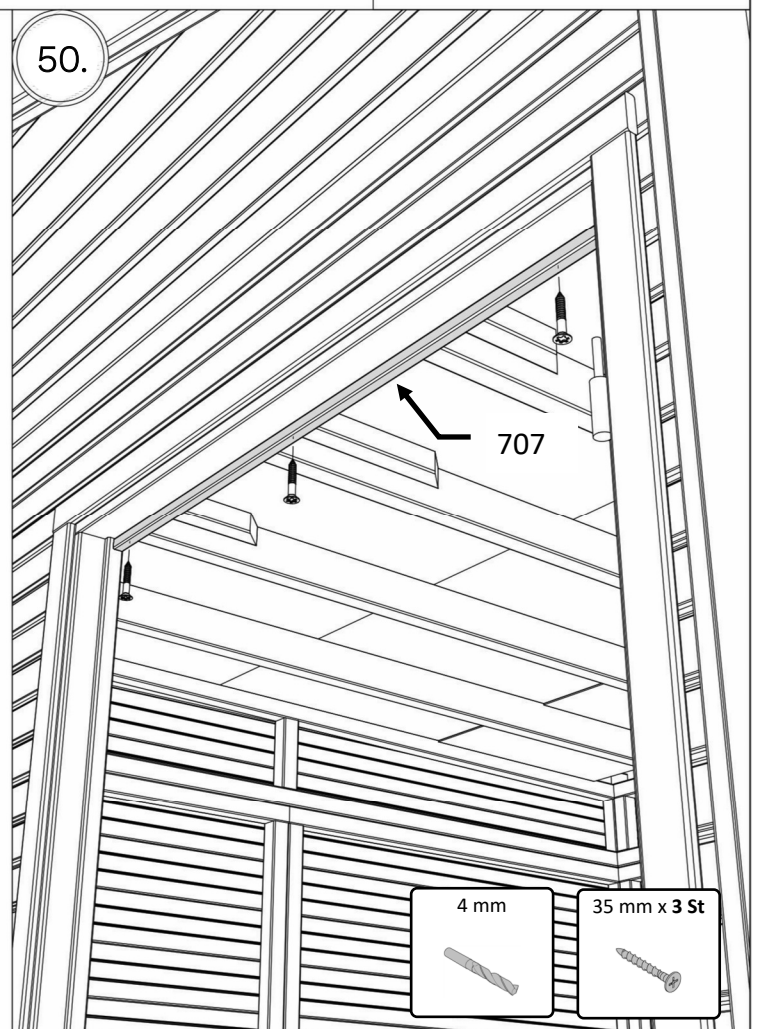
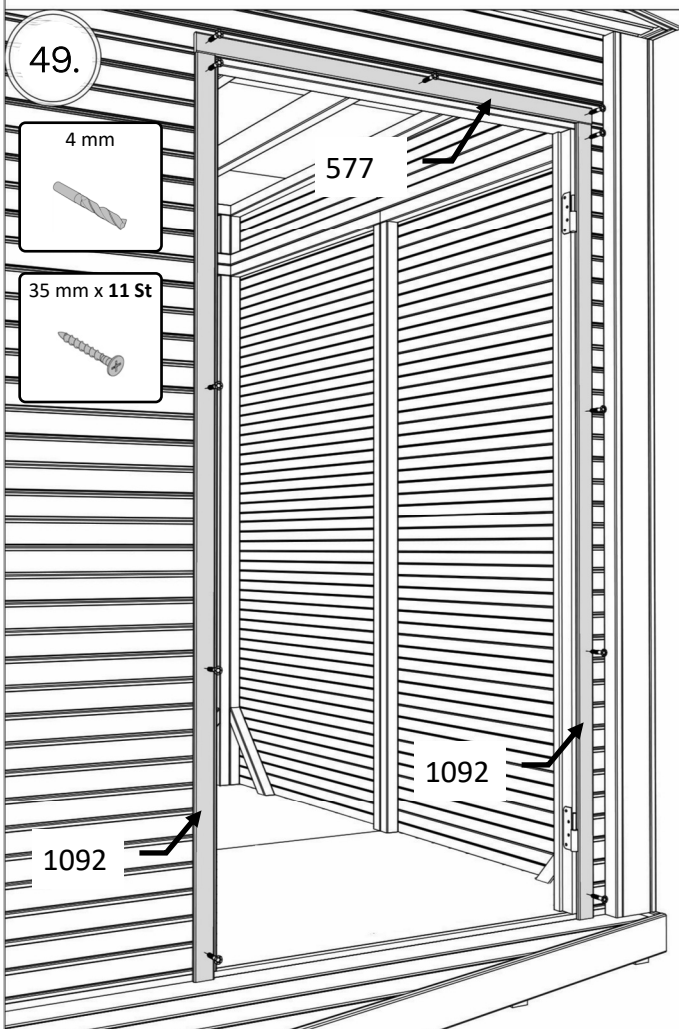
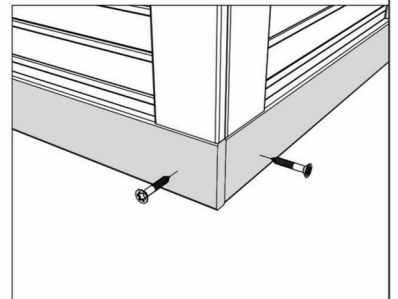
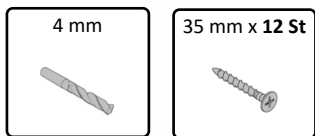
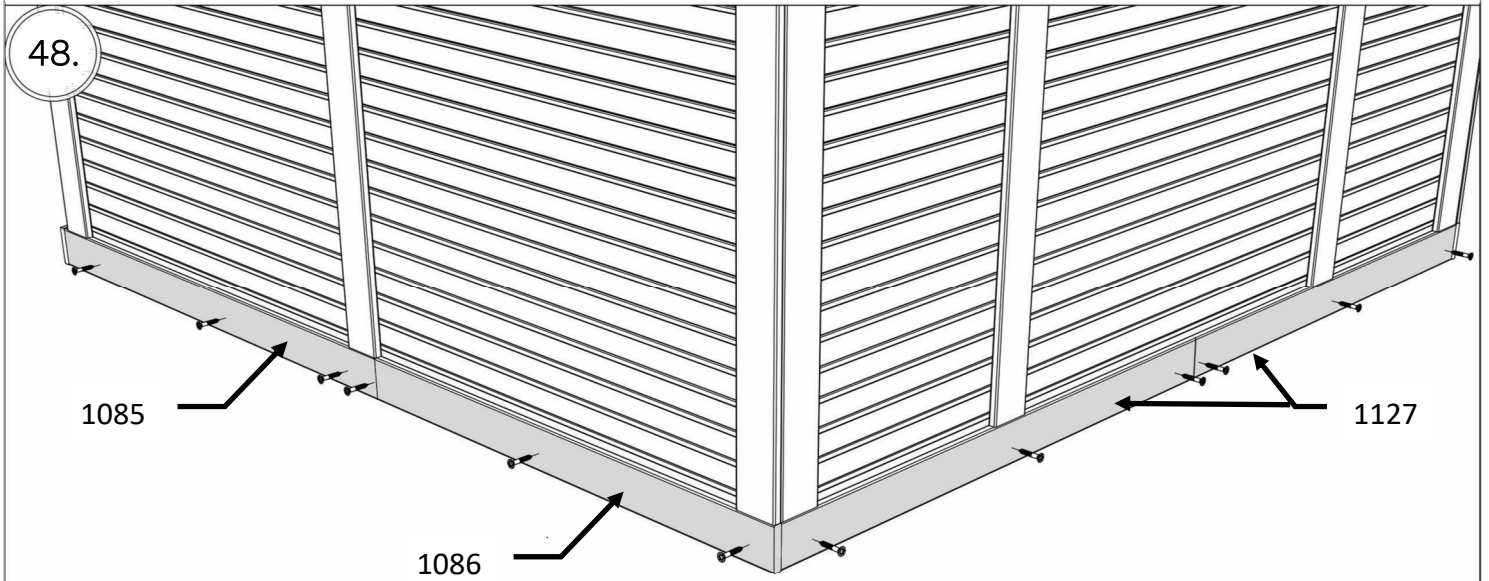

BCON1(NF/AN)

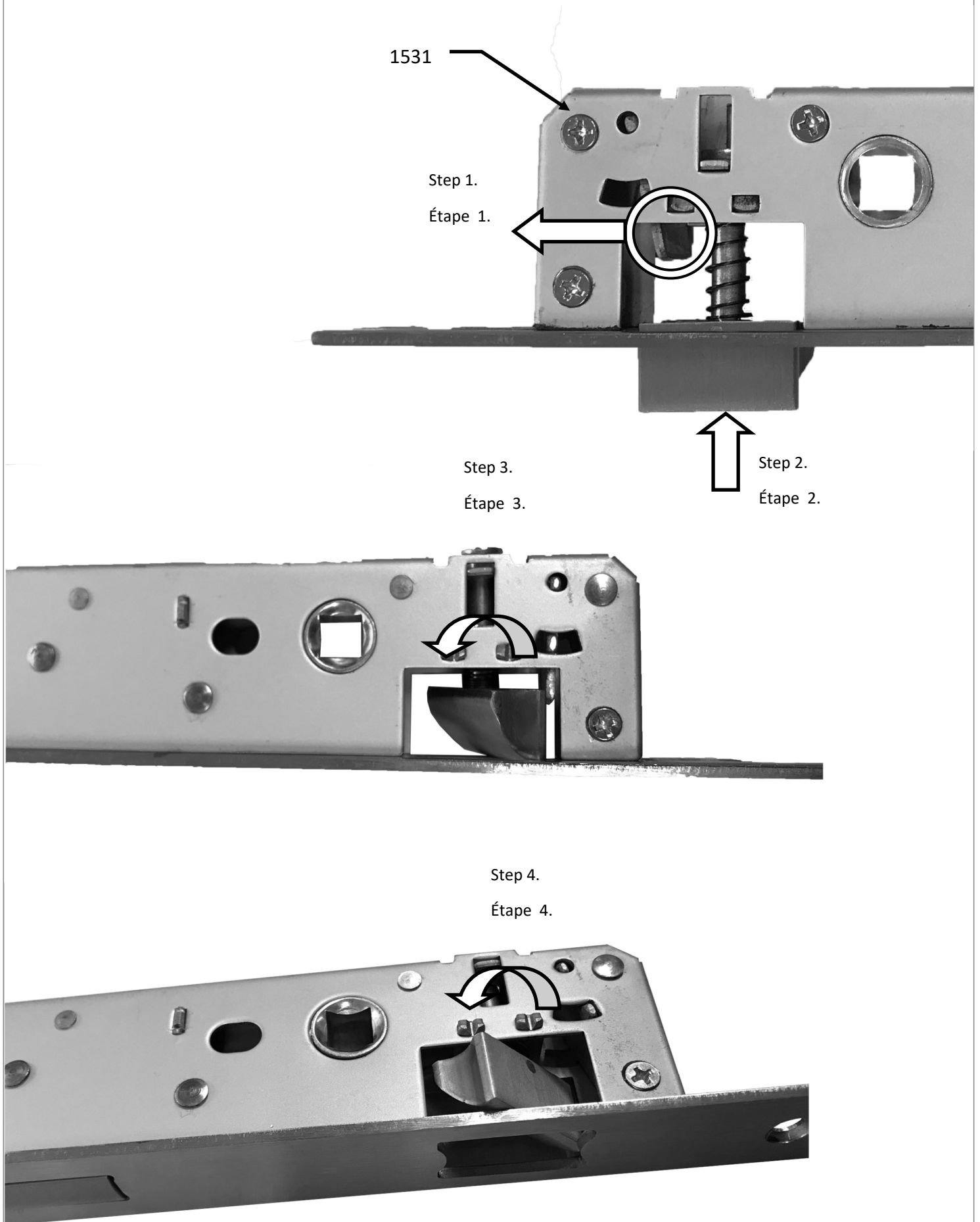

BCON1(NF)

51.

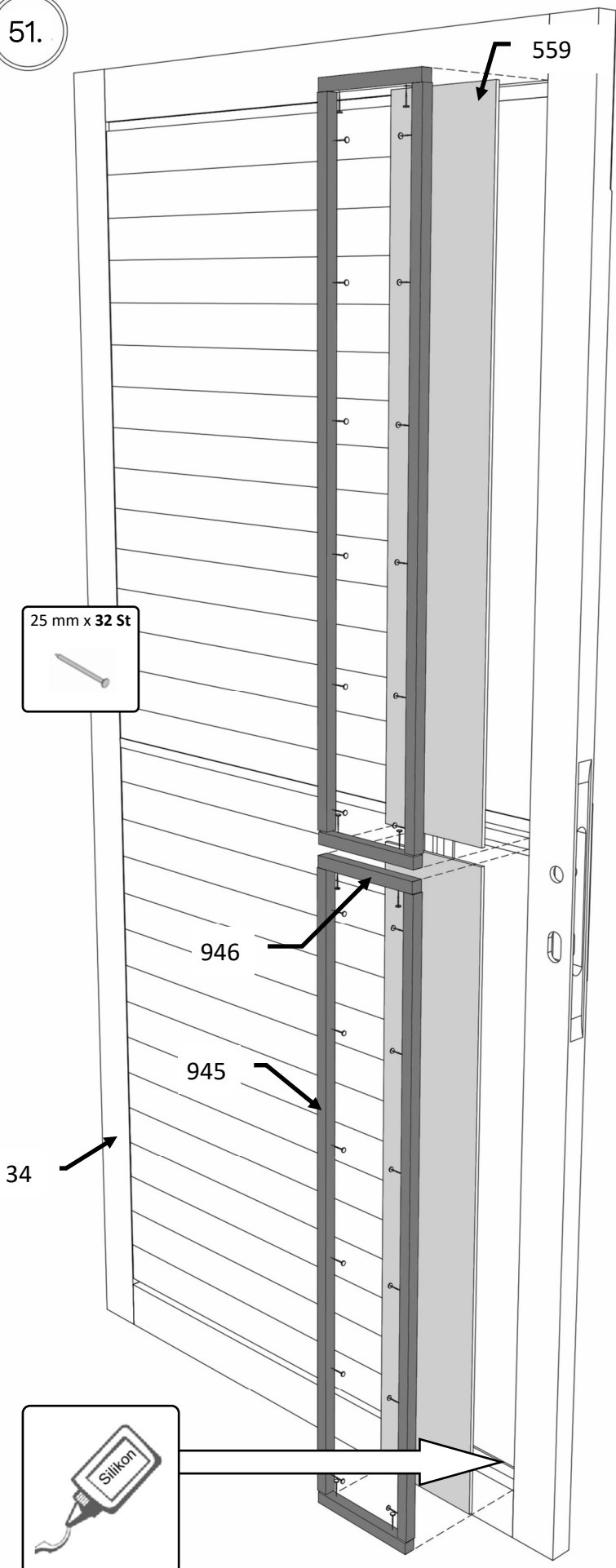

50 mm x 4 St



2X

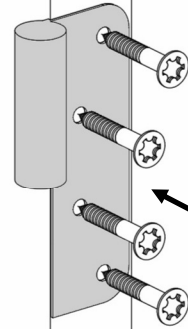

1527

35 mm x 6 St



1531

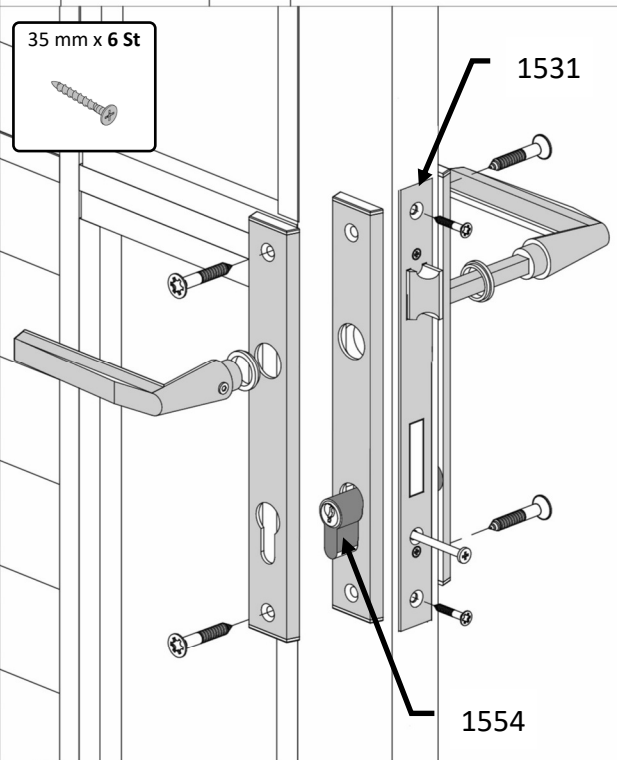

1554

52.

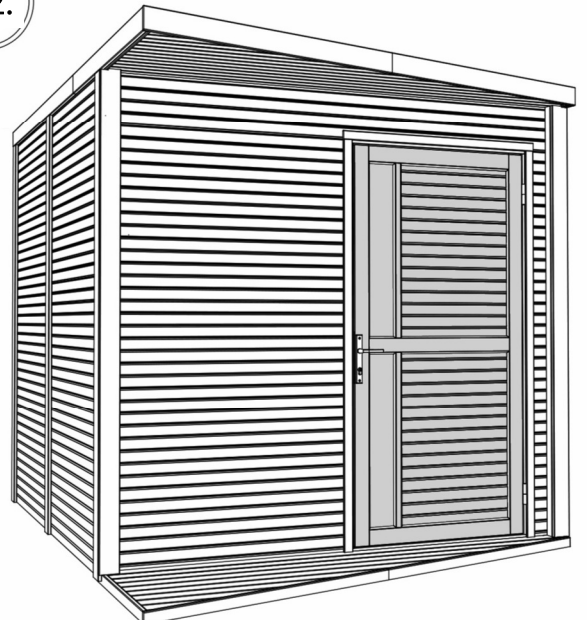

BCON1(AN)

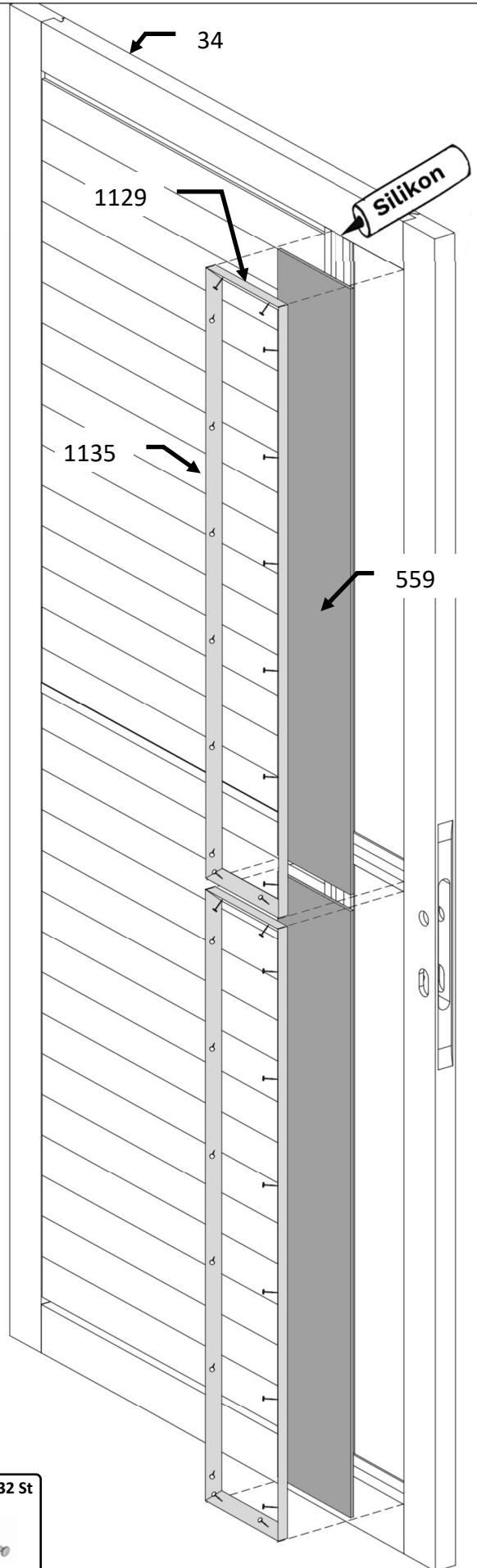
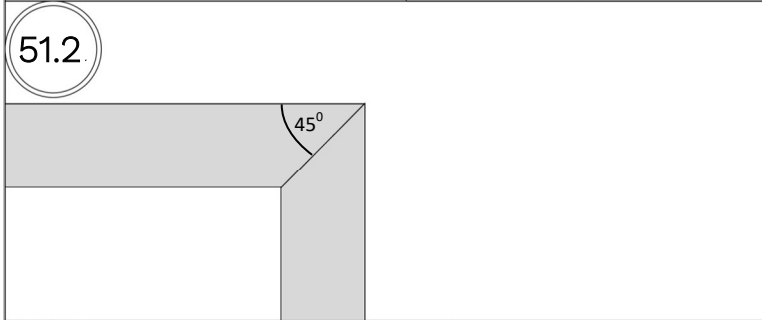
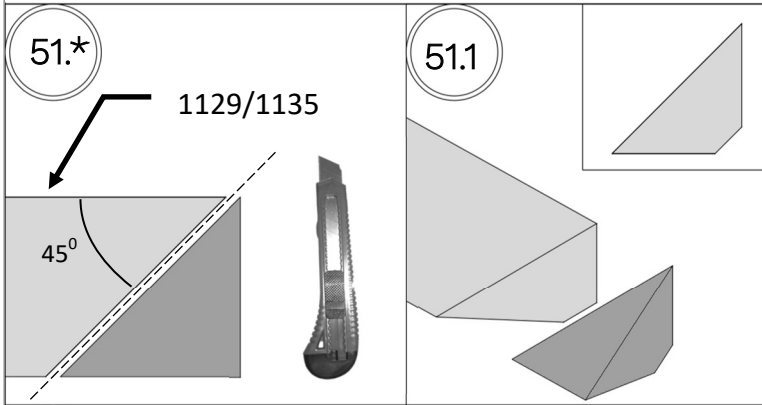

25 mm x 32 St



BCON1(NF/AN)

Version 1.

1.

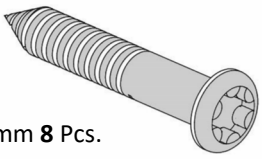

Ø3 x 19 mm 8 Pcs.

1557 2 Pcs.

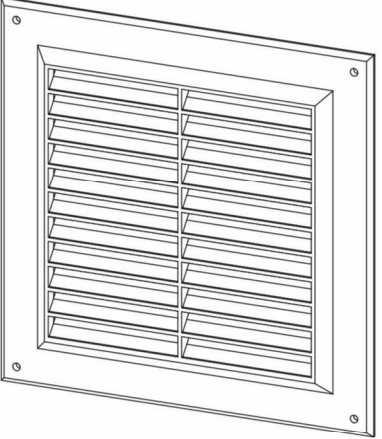

2.

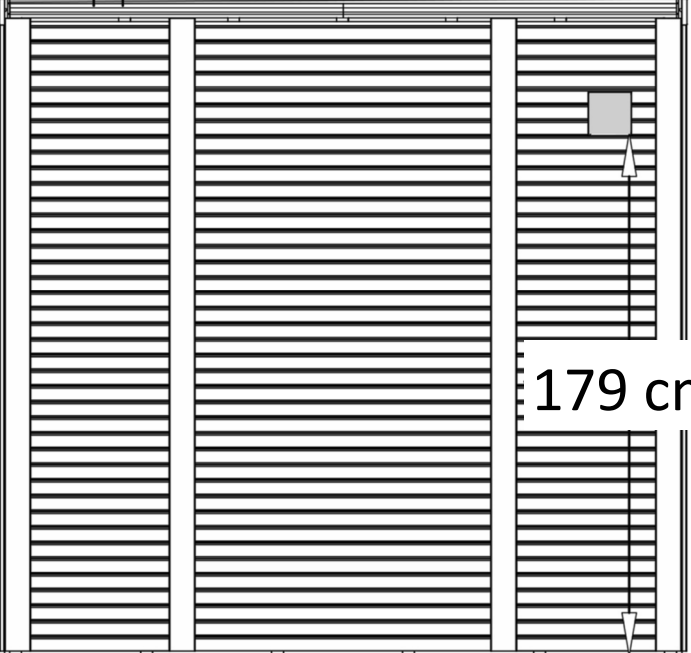

179 cm

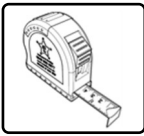
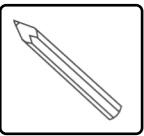

3.

110 mm

110 mm

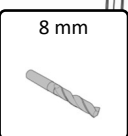

8 mm



4.

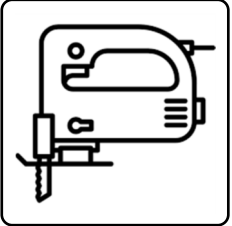

5.



Silikon



19 mm x 4 St



6.



19 mm x 4 St



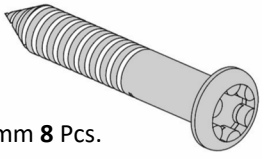

BCON1(NF/AN)

Version 2.

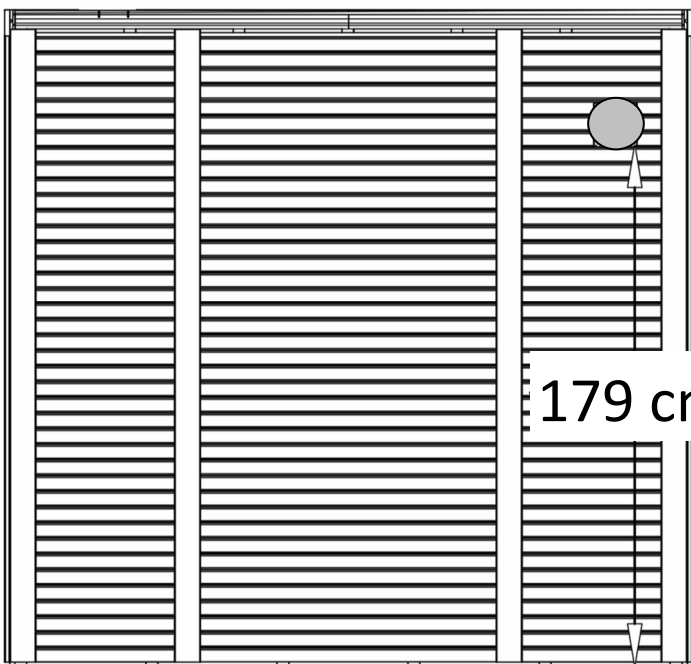
1. 
Ø3 x 19 mm 8 Pcs.
1557 2 Pcs.

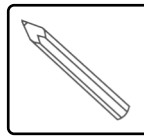
2. 
179 cm



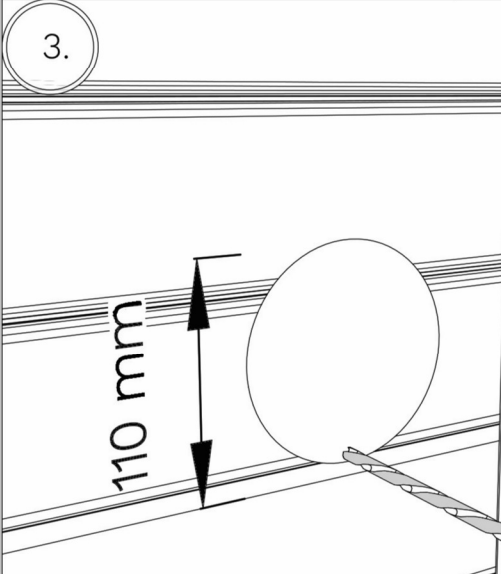

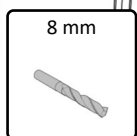

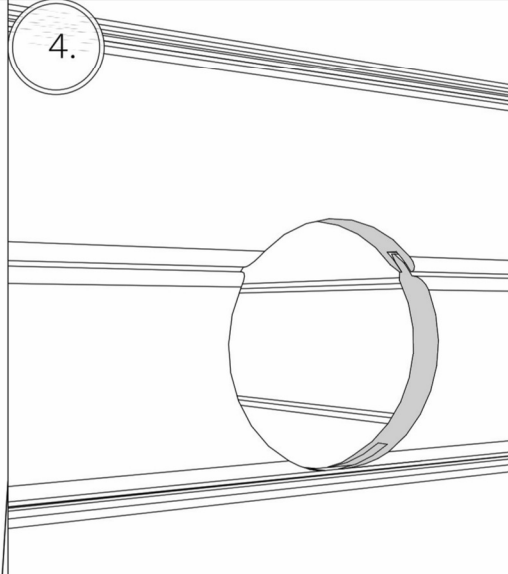
3. 
110 mm

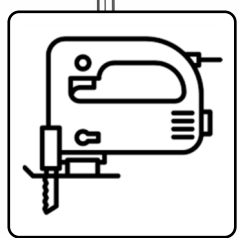
8 mm 

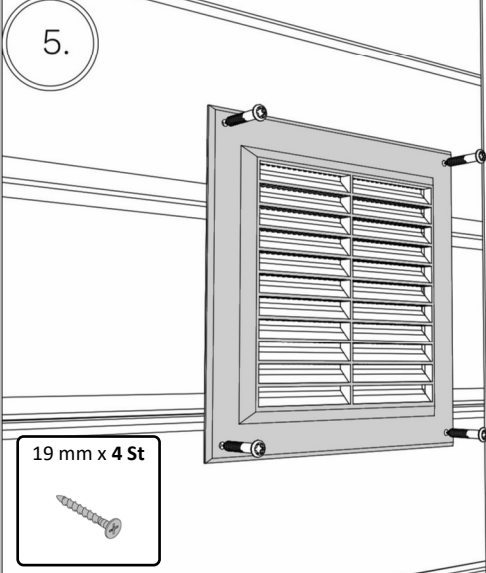
4. 



5. 
19 mm x 4 St 

Silikon 

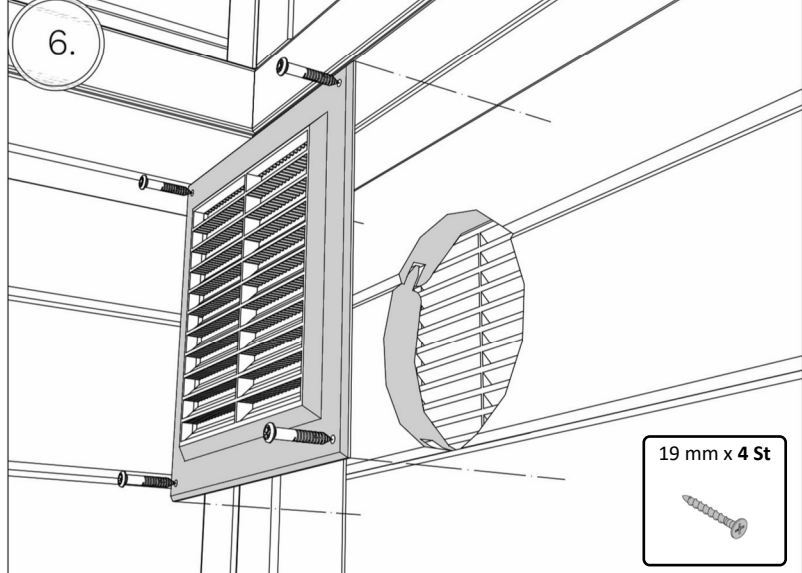
6. 
19 mm x 4 St 