

**20L one-way keg**

**1. Dimensions/Volume/Weight**

Diameter	341 mm
Height	433mm
Volume	20.8 L
Weight (empty keg)	1.9 kg

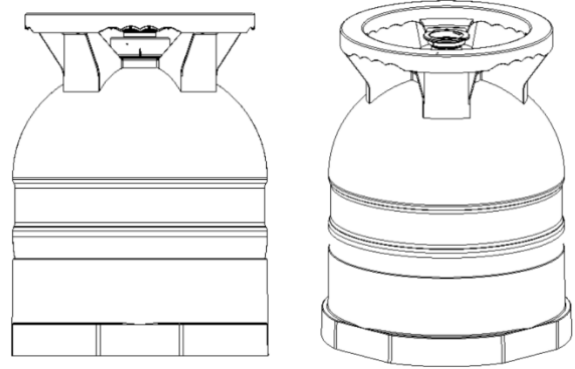

**2. Materials**

Inner bag	9 layers laminate, Multi layers high barrier
Valve	POM (food grade)
Spear housing	POM (food grade)
Springs (food contact)	Stainless Steel 304
Springs (non food contact)	Spring steel plated
Seals	TPE (food grade)
Keg	HDPE
Others	HDPE

**3. Shelf life**

Filled keg	Depends on filled beverage, up to 12 months
O <sub>2</sub> pick up per year	< 0.3 ppm
CO <sub>2</sub> loss per year	<5% (carbonization: 5.5g/L)

**4. Mechanical/physical Properties**

Operation temperature	0° C ~ 45° C
Maximum dispense pressure	3.5 bar
Maximum pressure	6 bar, free of explosion
Maximum force loading on spear	300 kg
Disposal	The Gprokeg is designed to give an extreme low impact on the environment, the empty keg is 100% recyclable, the product is 100% compliant to the EU Directive 94/62/EC

**5. keg coupler type**

S Type European Sankey	D Type US Sankey	A Type German Slider
---------------------------	---------------------	-------------------------

## 6. Food contact

EU food contact approval	All materials and additives used for the components intent to contact with food comply with European regulation EU10/2011
FDA	All materials and additives used for the components intent to contact with food comply with FDA cfr 175.300
Flavor/taste stability	All materials intent to contact with beverages are free of small molecular migration and free of chemical reaction with content of beverages, keeping flavor/taste stability of beverages.

## 7. Palletizing

### Empty keg

Pallet size	1200x1000x110mm, one-way
No. of layers	5
Kegs per layer	12
Kegs per pallet	60
Orientation	Upside up
Height	2.26m
Total weight	132kg
Pallets are wrapped with stretch film	

### Filled keg

No. of layers	4
Kegs per layer	12
Kegs per pallet	48
Orientation	Upside up
Height	1.88m
Max. layers in warehouse	8

