

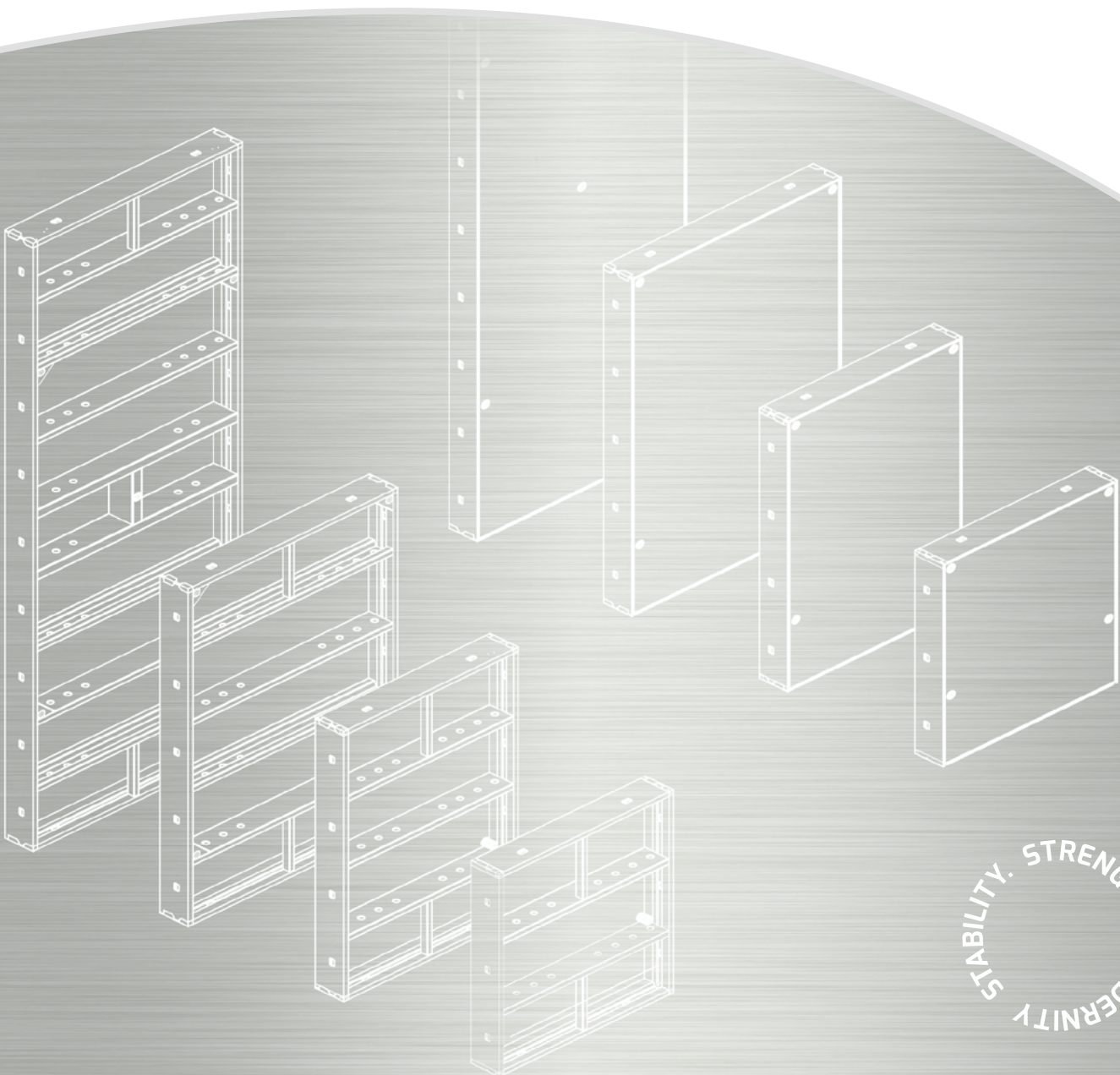

MOSTOTAL
SCAFFOLDING
FORMWORK

FORMWORK SYSTEMS

ASSEMBLY MANUAL





MOSTOSTAL
SCAFFOLDING
FORMWORK

FORMWORK SYSTEMS

ASSEMBLY MANUAL



www.altrad-mostostal.pl

STABILITY. STRENGTH.
MODERNITY.

Dear Sirs,

Reading these instructions carefully and following the recommendations included in it concerning the operation and maintenance of the equipment will significantly prolong the service life of this product and contribute to the satisfaction of the user connected with its usage.

The instructions constitute an integral part of the product equipment.

The assembly instructions below should be considered together with the formwork elements catalogue.

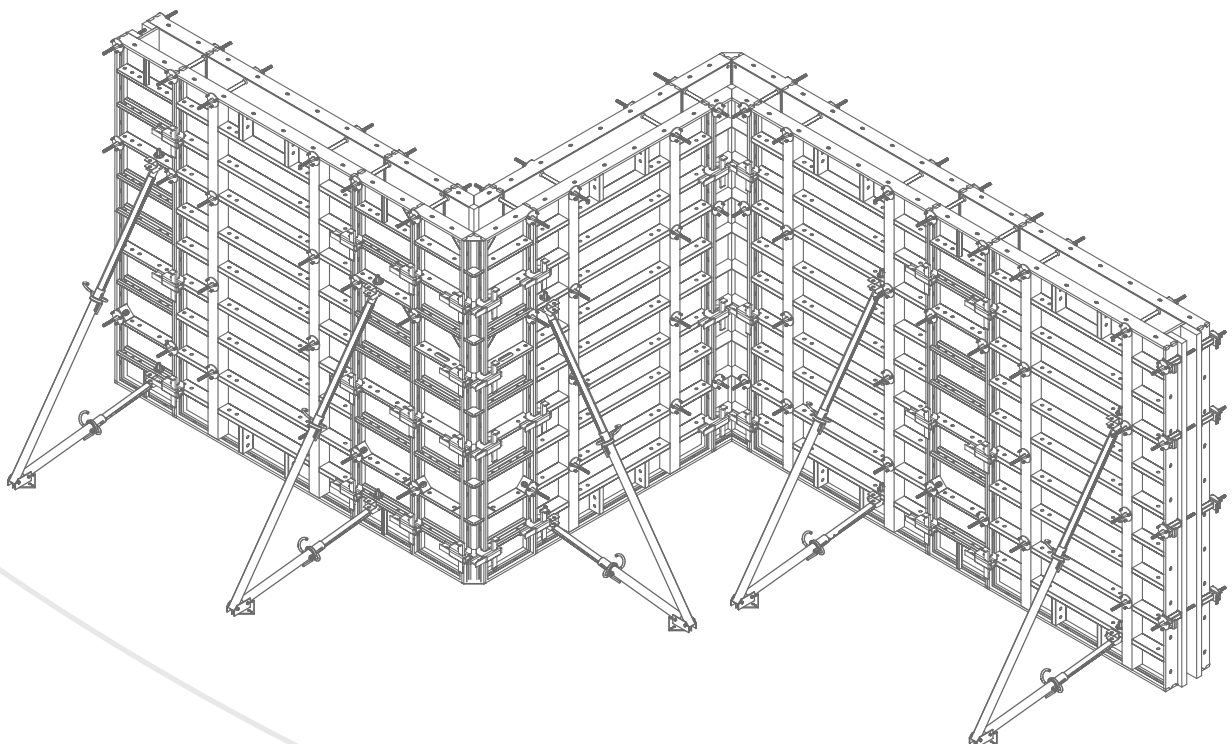

TABLE OF CONTENT

I Wall formwork – MIDI BOX

1. Technical description	4
1.1. Characteristics of the MIDI BOX wall formwork	4
1.2. Basic assembly and disassembly operations	5
2. LIGHT MIDI BOX (60 kN/m ²) board walls	5
2.1. Light MIDI BOX board dimensions and brace hole spacing	7
2.2. Straight walls	7
3. Heavy MIDI BOX (80 kN/m ²) board walls	8
3.1. MIDI BOX board dimensions and bowstring holes spacing	8
3.2. Straight walls without superstructures	10
3.2.1. Walls 150 cm, 270 cm, 300 cm or 330 cm high	10
3.3. Walls with superstructures	14
3.4. Walls with the superstructure bracket	16
3.5. Adjustment of the wall length when using the filling inserts	17
3.6. Wall finishes	18
3.7. Forming when the wall thickness is changed	20
3.8. Working platforms	21
3.9. Transporting the elements on the construction site	22
4. Corners	23
4.1. Internal corners	23
4.2. External corners	23
4.3. Obtuse and acute angle corners	26
5. High wall forming – climbing formwork	27
5.1. SKK cone assembly	27
5.1.1. Fastening the SKK cones to the shuttering board	27
5.1.2. Fastening of the anchor to the reinforced concrete structure – manners	28
5.2. Wall bracket assembly	29
5.3. Assembly of the climbing formwork bracket catches	30
5.4. Assembly of the transportation segments on the building structure	30
5.5. Installing the wall formwork on the brackets	31
6. Post forming	32
6.1. Forming the posts by using the zero corner and the (normal) shuttering boards	32
6.2. Forming posts by using corner formwork lock and formwork boards (regular)	35
6.3. MIDI BOX SP board dimensions and brace system hole spacing	37
6.4. Forming posts by using SP boards (post boards)	37
7. Lift shaft forming	40
7.1. Lift shaft formwork	40
7.2. Lift shaft formwork assembly and disassembly	40
8. Radial wall erection	44
9. Plumbing of walls and posts	45
9.1. Walls and posts h ≤ 3,0 m high	45
9.2. Walls and posts h > 3,0 m high	46
10. One-sided formwork	47
10.1. One-sided formwork with the horizontally positioned boards	49
10.2. One-sided formwork with the vertically positioned boards	50
11. Determining the maximum concreting speed in a practical manner	51

II Ceiling formwork

12. Girder and plywood ceiling formwork	54
12.1. Guidelines concerning the assembly of the girder and plywood ceiling	54
12.1.1. Preparations	54
12.1.2. Assembly of the girder and plywood formwork	55
12.1.3. Disassembly of the girder and plywood formwork	57
12.2. General rules for the ceiling formwork disassembly	58
12.3. Props and girders spacing selection criteria	58
12.4. Alternative methods of shoring of the girder and plywood ceiling formwork	62
13. Sample binder forming	63
14. ALUstrop ceiling formwork	64
14.1. Permissible thickness of the ceiling erected with the ALUstrop formwork	65
14.2. ALUstrop ceiling formwork assembly	66
14.3. ALUstrop ceiling formwork disassembly	71
14.4. Maintenance of the ALUstrop ceiling formwork components	72

1. TECHNICAL DESCRIPTION

MIDI BOX are spatial and reusable formwork. They are used for forming the continuous footing, square or rectangular section walls and posts, binders, lift shafts and many other both typical and atypical structural elements of virtually each facility. Formwork system elements include the entire series of the frame boards filled with plywood and fitted with the complete set of the connecting and stiffening, compensating and formwork plumbing elements. The wide possibility range and continuous system improvements and innovations allow us to meet the more and more sophisticated challenges of the contemporary construction sector, industry or power engineering sector.

1.1. Characteristics of the MIDI BOX wall formwork

Light MIDI BOX system is a medium load wall formwork – permissible fresh concrete pressure is 60 kN/m^2 . The basic components of the system include formwork boards 90, 120, 150 and 270 cm high and 25-90 cm wide.

Heavy MIDI BOX system is a high load wall formwork – permissible concrete pressure is 80 kN/m^2 . The basic components of the system include formwork boards 150, 270, 300 and 330 cm high and 25-240 cm wide.

The 60 kN/m^2 and 80 kN/m^2 boards feature various shapes of frame holes so that you can distinguish them (fig. 1.1).

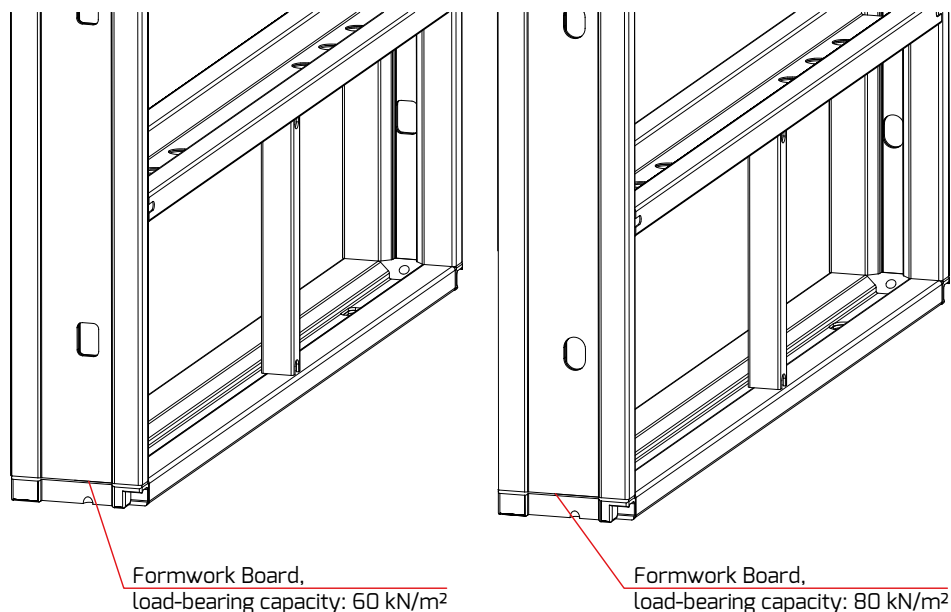

Fig. 1.1

Formwork boards are frames reinforced with the additional closed section ribs made of high-grade steel. The boards are covered with the multilayer waterproof plywood with resin coat on both sides. It ensures high concrete surface quality and long planking life. When the formwork is removed the concrete surface does not need any plaster other than thin plaster or putty.

The internal profiles or “ribs” that reinforce the frame are densely installed to prevent plywood from deformation due to concrete pressure. Special handles installed in the frame ribs ensure easier manual formwork board handling while the smartly designed ribs with technical holes may be used to hang the work platform brackets. The platforms are used for supervision activities inside the formwork and are very helpful when the concrete mix is vibrated.

The special systematic technical holes are also provided in the external steel frame structure profile and they can be used to join the boards and other system components required for planking. In this case, braces and centring nuts are used. Another basic part that joins the formwork boards and other related components is the universal wedge lock. The lock also stiffens and aligns the planking plane. For larger wall surface areas additional horizontal and vertical load-bearing stiffening is provided by using special system transoms and beams.

The opposite formwork walls are joined by the Dywidag B15 threaded rods (braces) and flange nuts – permissible joint load is 90 kN. The brace rods are covered by the PCV spacing tubes cut to length that indicate the space between the opposite boards thus determining the concreted wall thickness. The spacing tubes are used with the sealing cones.

The corners are formed with the internal, external and articulated system corners of various dimensions.

The system also includes the tilting and sloping supports that ensure the formwork structure is vertical.

1.2. Basic assembly and disassembly operations

MIDI BOX system allow for the selection of the board width in the module every 5 cm while considering the horizontal boarding position. However, as regards the vertical position the boards are 90 cm, 120 cm, 150 cm, 270 cm, 300 cm and 330 cm high. The shuttering boards can be connected with each other in any configuration. You should also remember that the basic stiffening is obtained when the boards are positioned vertically. The horizontal position should be considered the supplementary solution. When assembling the formwork you should use the elements which are in perfect condition without any signs of damage.

Construction which is prepared very well in terms of organisation and equipment has a decisive influence on the speed of the works completion and their quality thus on the logistics and economy of the construction. The works should start from the thorough technical design analysis, establishing a timetable for the individual works connected with the concreting cycle and splitting the facility into the individual stages. Selecting the appropriate range of the MIDI BOX boarding elements is also important. Each and professional preparation of the strategy of the construction completion strategy, any facility eliminated the outages and organisational chaos so that the work is smooth and pleasant. The equipment may be selected and the boarding design may be prepared by using the computer software called EuroSchal.

Before the boarding assembly you should absolutely remember to cover the board sheathing surface with the antiadhesive liquid from the side where the board contacts concrete. To do this you can use the normal painting brush or a conventional oilproof substance sprayer.

During the concreting cycle you should pay particular attention not to exceed the permissible concrete pressure on the formwork walls. The description and practical example of the concreting speed are shown in Chapter 11 of these instructions. To prolong the boards life when compacting the concrete with the internal vibrators you should avoid contact of their endings with the sheathing plywood.

NOTE: the Assembly instructions do not replace the EHS instructions on the construction site!

The construction manager is responsible for the assembly of the formwork and checking if it is correctly assembled!

The boarding may be disassembled only when the appropriate concrete strength has been obtained i.e. when the structure is stable and ensures that the element surfaces and edges are resistant to damage (~24 h). These works should start from the disassembly of the equipment such as inspection brackets, tilting props, nuts, locks, tightening beams, edge catches, tighteners etc. After the formwork has been disassembled you should remove concrete from the boards and protect them with the antiadhesive liquid. They should be stored on a hardened and even ground. The boards should be stacked vertically according to their dimensions.

During the assembly and disassembly, and storage of the boards you should not move them the sharp edges, throw them down or press with heavy elements. Damage that occurs on the boards should be constantly removed before the boards are used on the construction site again.

When assembling the formwork you should use the elements which are in perfect condition. Elements with signs of damage can't be used. Especially you can't use:

- elements with signs of corrosion or cracks in connection zones (welds),
- supporting elements with visible damage such as bends and deformations of cross-sections,
- screw elements with damaged threads, with bent pins or hard-turning nuts,
- elements with missing components.

Damaged elements have to be exchange on the ones in perfect condition. Elements which can not be used nor fixed have to be removed.

Elements have to be inspected at least once every 6 months. It is recommended to check all elements each time they supposed to be used. An authorized person or site manager is responsible for the inspection.

Producer is not liable for damages resulting from incorrect assembly, overloading or use of elements contrary to their intended use.

2. LIGHT MIDI BOX (60 KN/M²) BOARD WALLS

2.1. Light MIDI BOX board dimensions and brace hole spacing

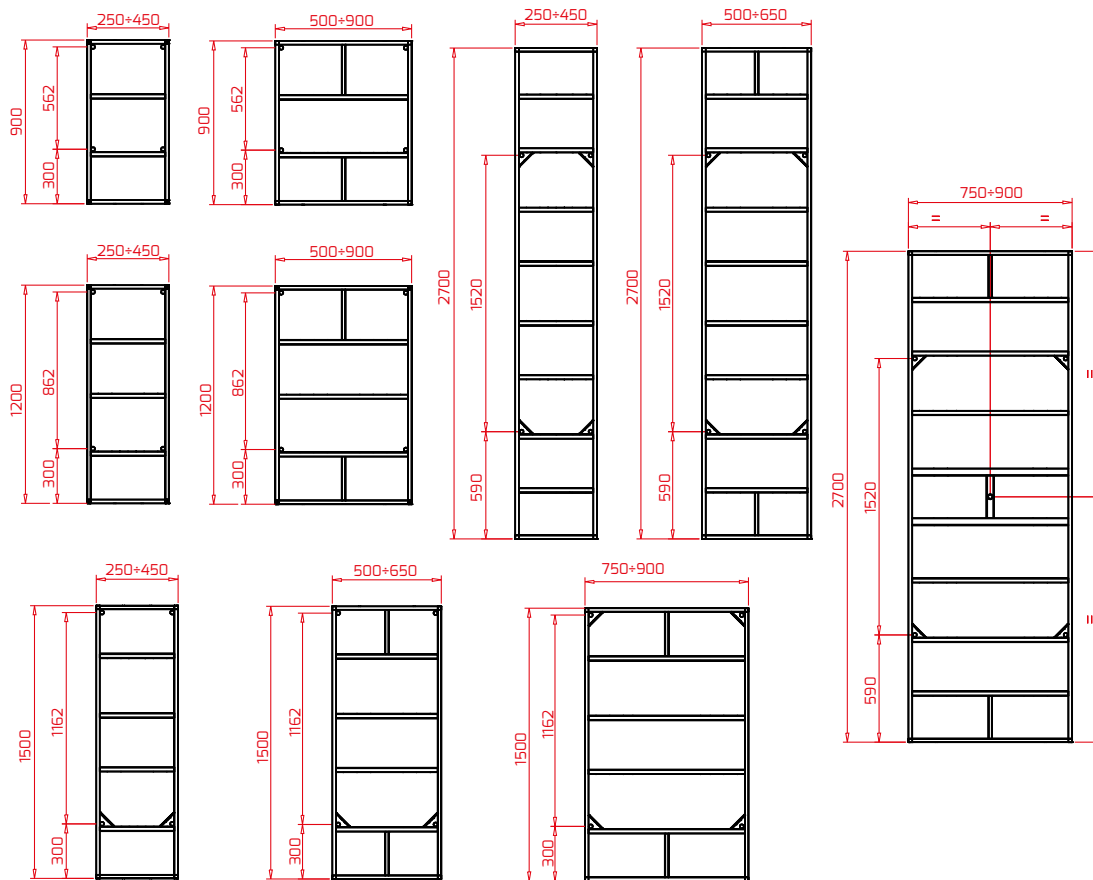

Fig. 2.1

2.2. Straight walls

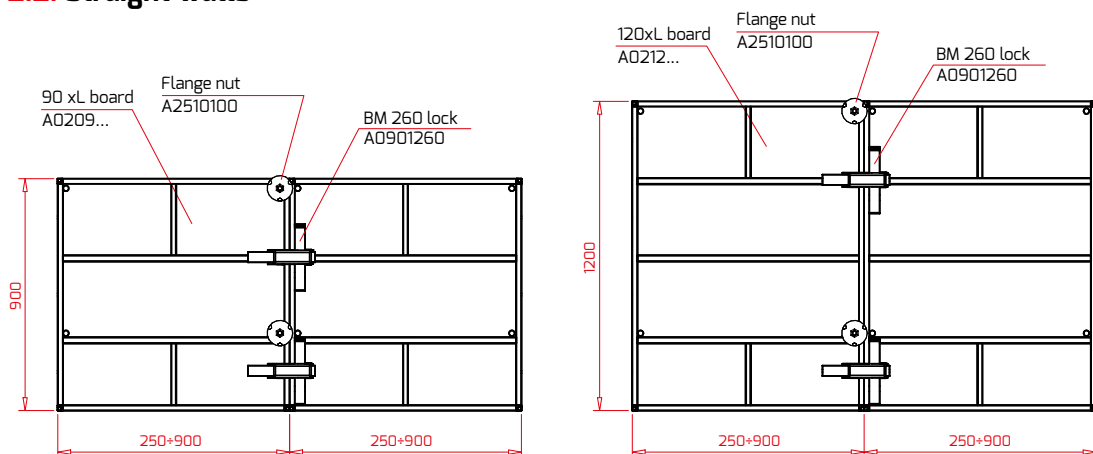

Fig. 2.2

Board dimensions H x L	Number of locks in the board contact point	Number of bowstrings in the board contact point
90 x (25+90)	2	2
120 x (25+90)	2	2

Walls that are 90 cm and 120 cm high should be joined using two BM260 locks with a single contact point. Refer to the next part of the manual for the details on the straight walls 150 cm and 270 cm high, corner installation, wall alignment, installing finishes and installing the boards one on the other.

NOTE: the Assembly instructions do not replace the EHS instructions on the construction site!

The construction manager is responsible for the assembly of the formwork and checking if it is correctly assembled!

3. HEAVY MIDI BOX (80 KN/M²) BOARD WALLS

3.1. MIDI BOX board dimensions and bowstring holes spacing

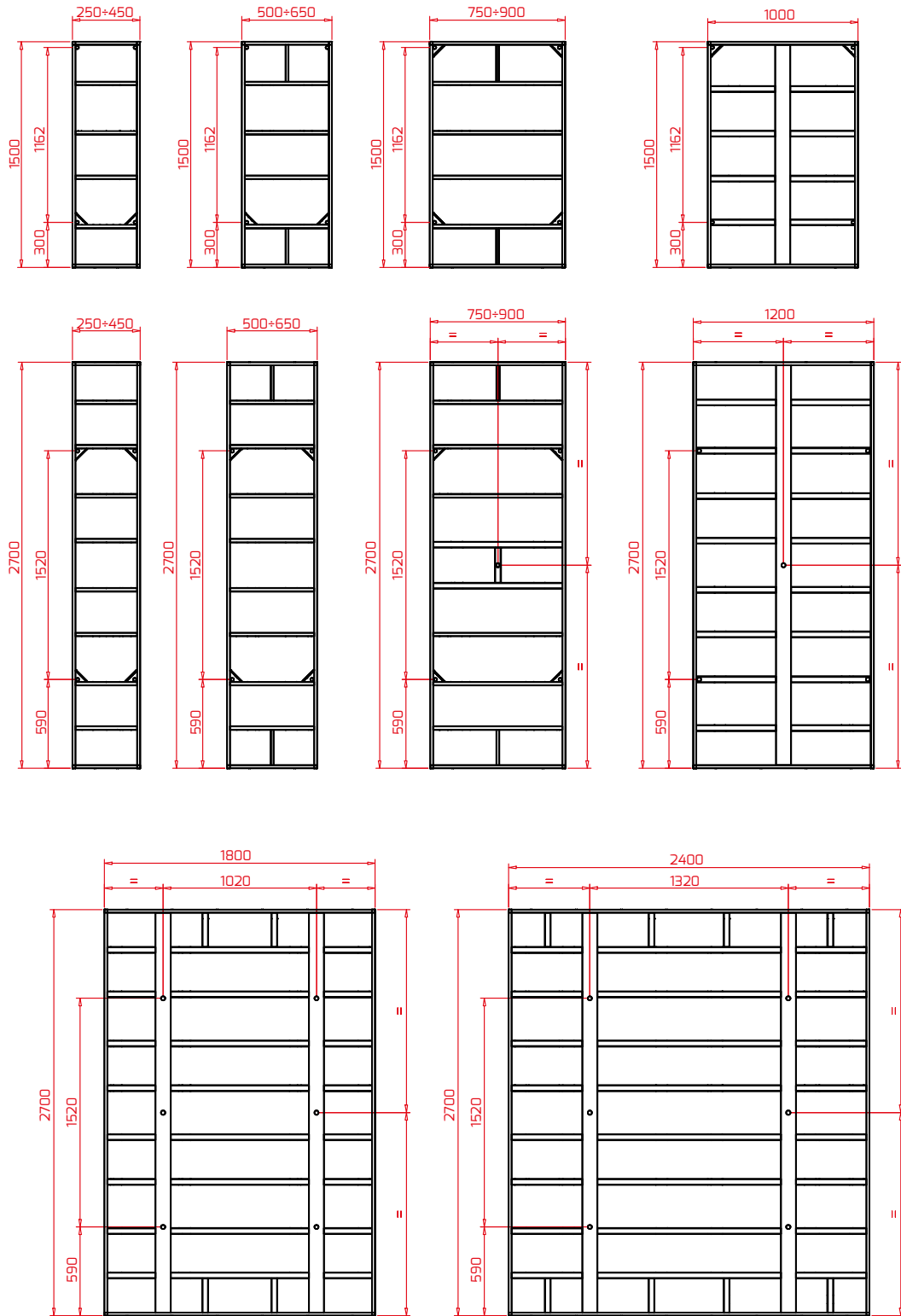

Fig. 3.1a

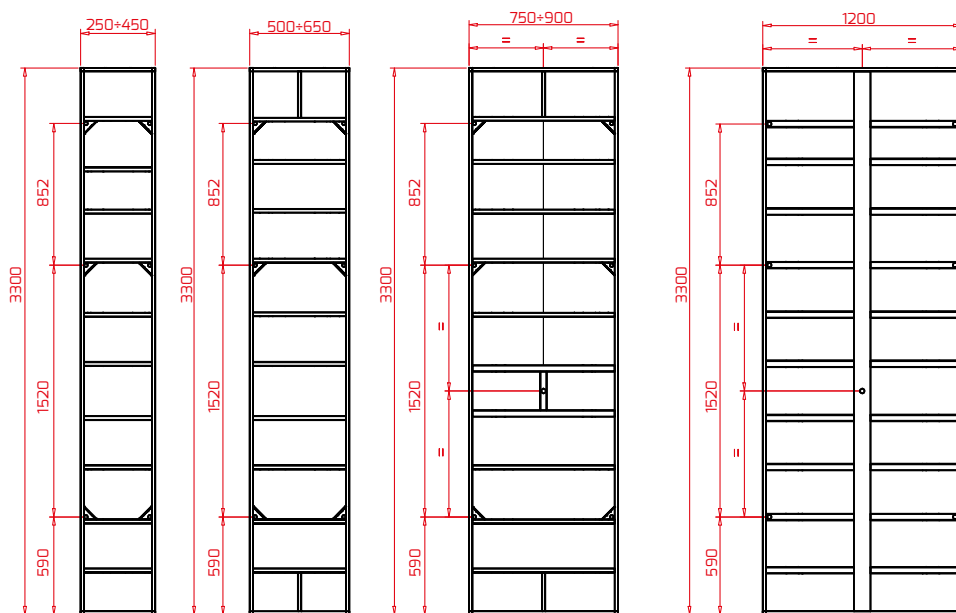
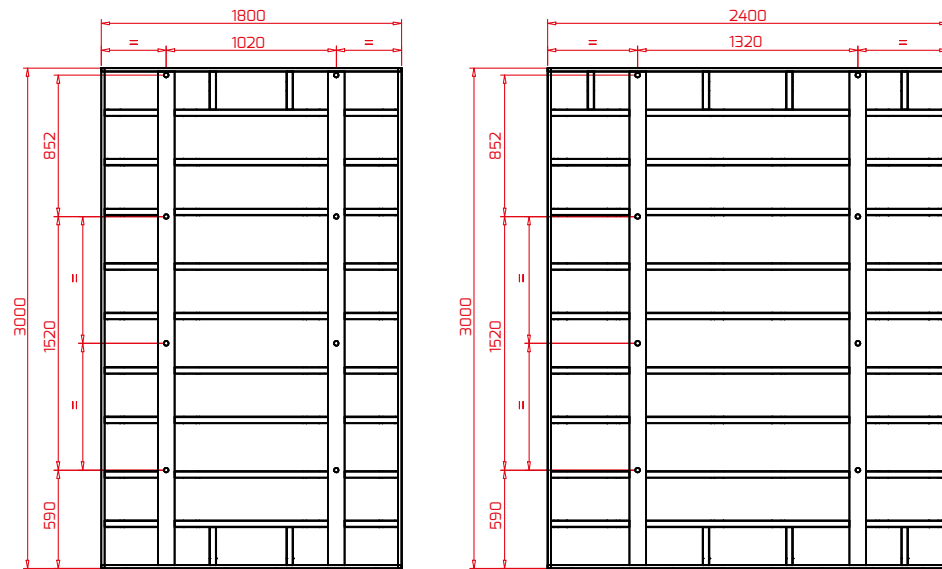
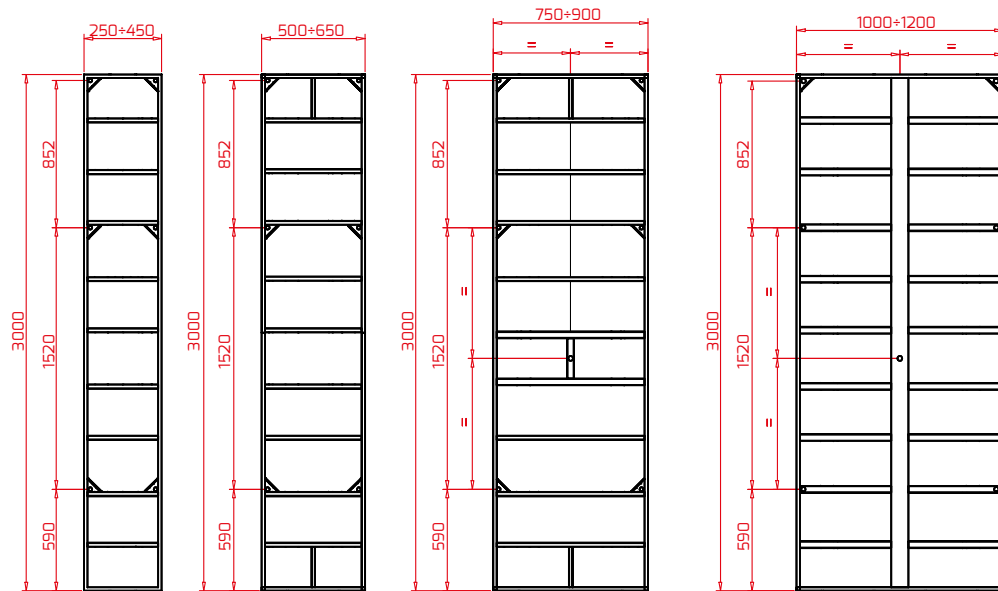

Fig. 3.1b

NOTE: the Assembly instructions do not replace the EHS instructions on the construction site!
 The construction manager is responsible for the assembly of the formwork and checking if it is correctly assembled!

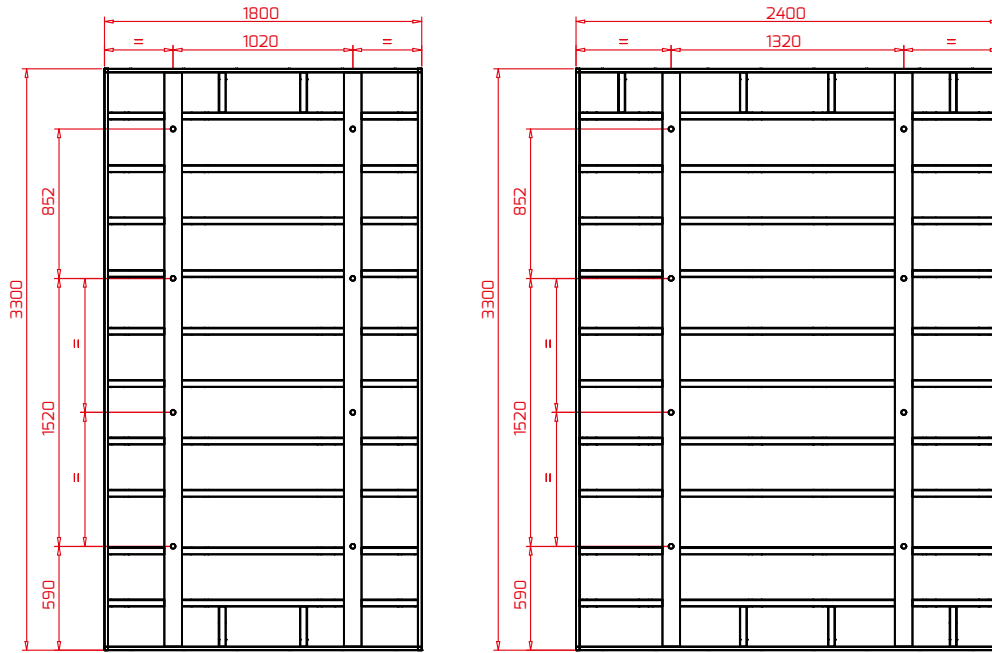

Fig. 3.1c

3.2. Straight walls without superstructures

3.2.1. Walls 150 cm, 270 cm, 300 cm or 330 cm high

Walls 150 cm high are connected with two BM260 locks in one board contact point. However, walls 270 cm, 300 cm and 330 cm high are connected with three BM260 locks in one board contact point. The number of the connecting elements depends on the height and width of the boards. The accurate numbers are specified in the tables below.

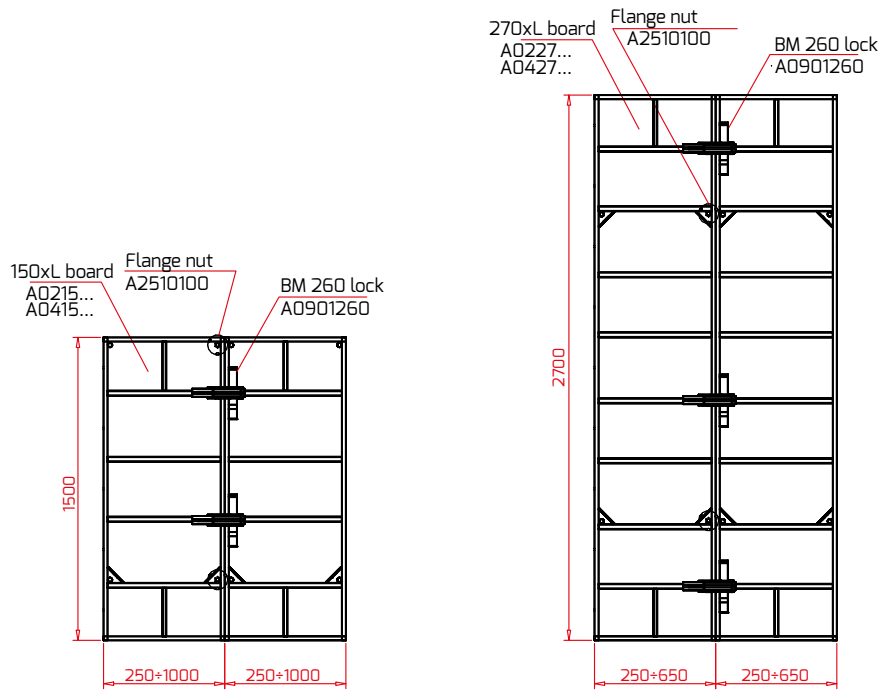

Fig. 3.2a

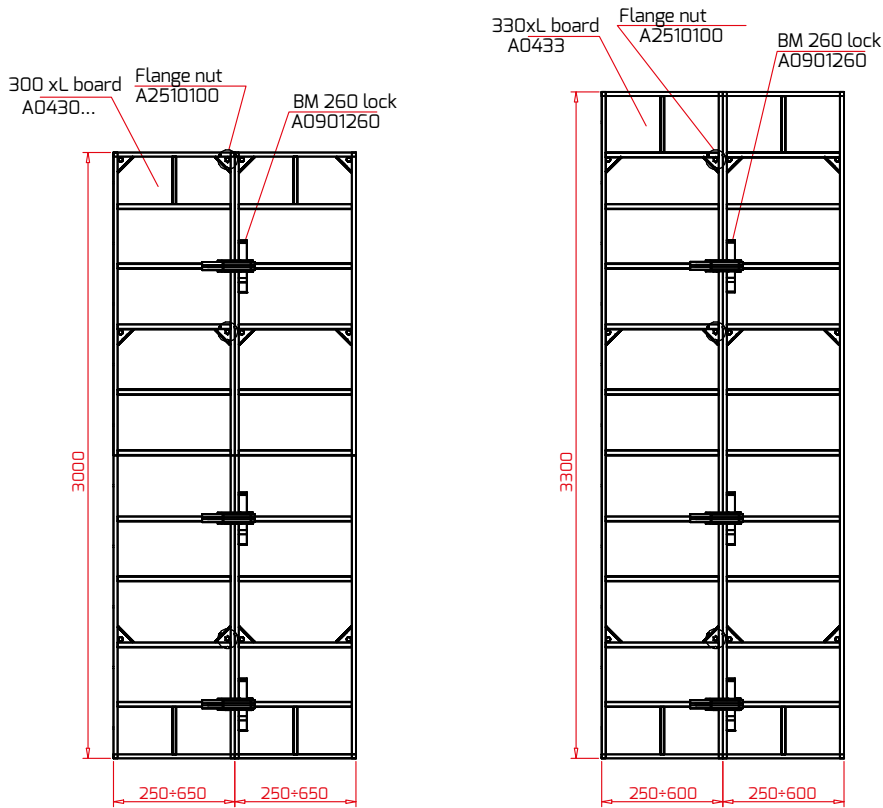
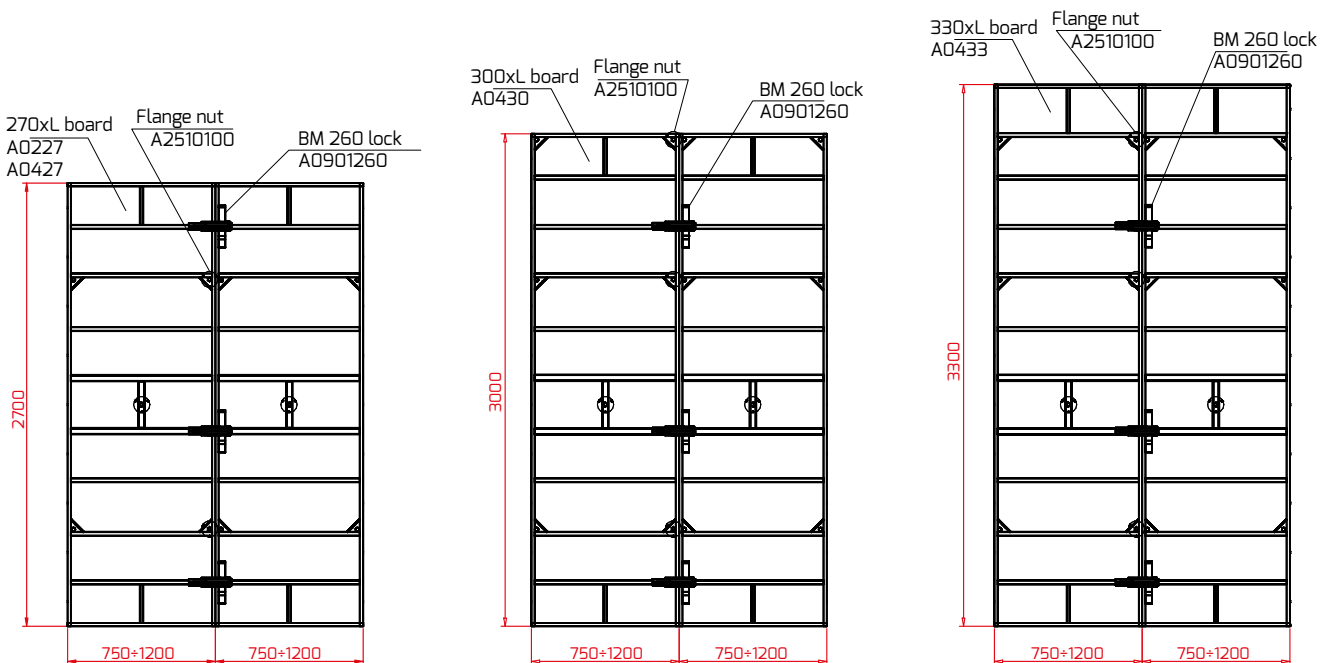

Fig. 3.2b

Board dimensions H x L	Number of locks in the board contact point	Number of bowstrings in the board contact point
150 x (25÷100)	2	2
270 x (25÷65)	3	2
300 x (25÷65)	3	3
330 x (25÷65)	3	3



Wymiary płyty H x L	Number of locks in the board contact point	Number of bowstrings in the board contact point	Number of central bowstrings
270 x (75÷120)	3	2	2
300 x (75÷120)	3	3	2
330 x (75÷120)	3	3	2

NOTE: the Assembly instructions do not replace the EHS instructions on the construction site!

The construction manager is responsible for the assembly of the formwork and checking if it is correctly assembled!

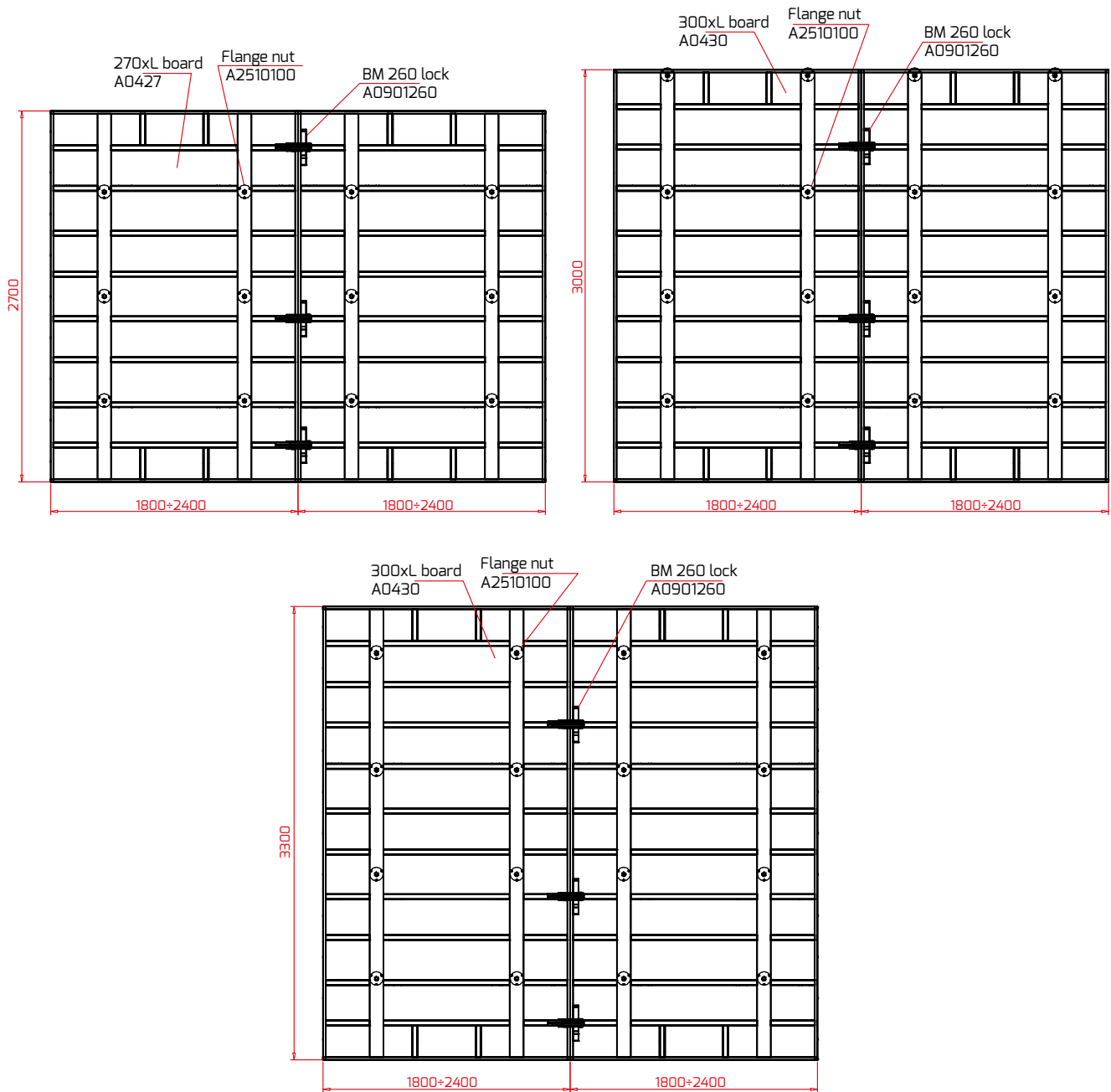

Fig. 3.4

Board dimensions H x L	Number of locks in the board contact point	Number of bowstrings
270 x (180+240)	3	12
300 x (180+240)	3	16
330 x (180+240)	3	16

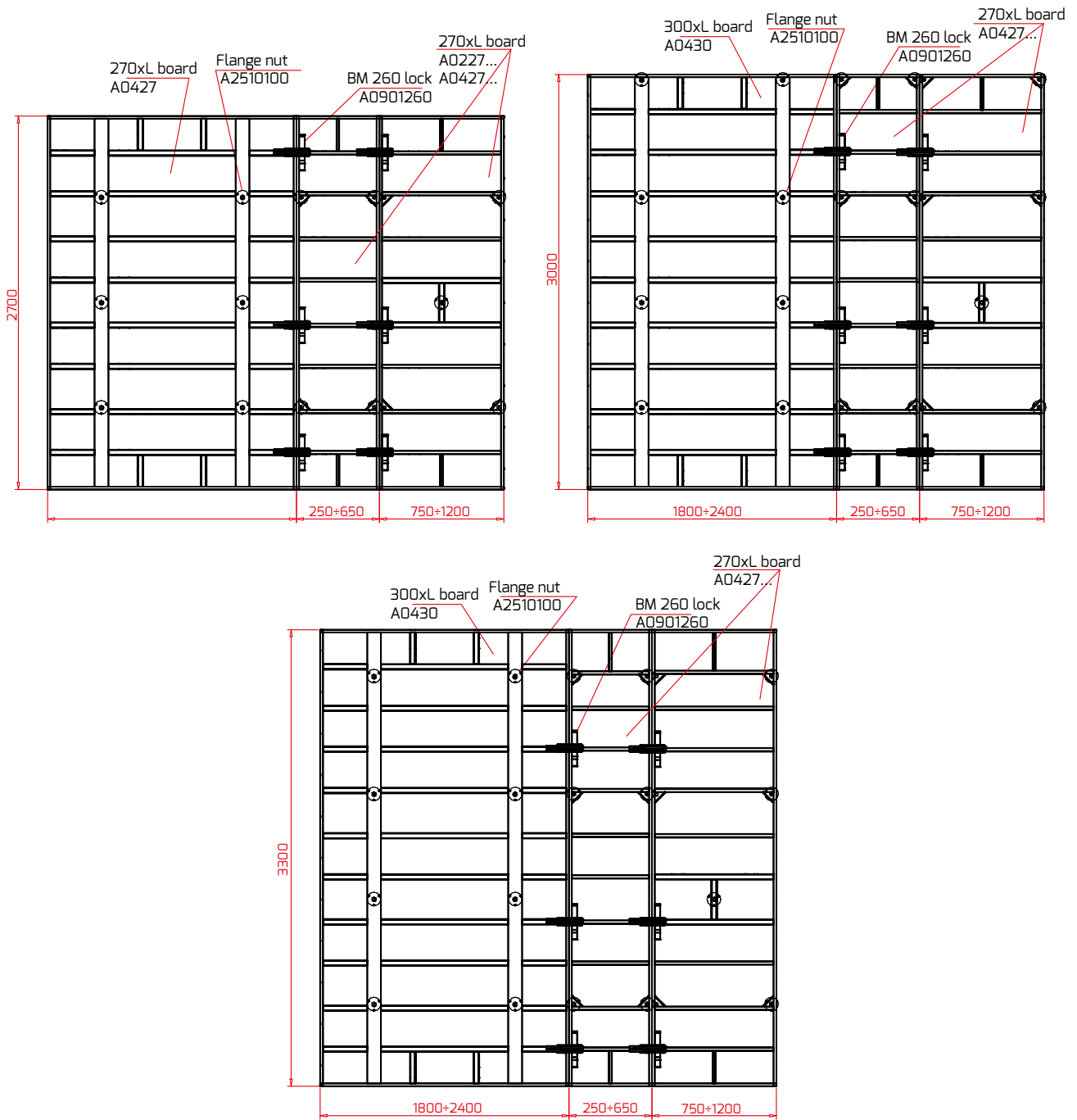

Fig. 3.5

Board height H (cm)	Number of locks	Number of bowstrings
270	6	13
300	6	18
330	6	18

NOTE: the Assembly instructions do not replace the EHS instructions on the construction site!
 The construction manager is responsible for the assembly of the formwork and checking if it is correctly assembled!

3.3. Walls with superstructures

The walls with formworks are connected in the following manner:

- as regards the basic (bottom) layer connect as shown above, i.e. according to item 3.2. of these instructions;
- the shuttering boards in the superstructures are connected with the BM 710 locks - fitted with a long straightening foot (710 mm) so that the plane that straightens the formwork is larger. Instead of the BM 710 lock you can use the stiffening beam or the formwork transom (fig. 3.6);
- when installing the superstructures vertically on the boards instead of the BM 710 locks you can use the stiffening beams to increase the formwork stiffness (fig. 3.7);
- when installing the superstructures vertically on the boards 150 cm, 270 cm, 300 cm and 330 cm high the shorter boards are installed at the formwork bottom due to the greater density of the formwork bowstrings; **Joining heavy boards (A04 -) with light boards (A02 -), place the concrete at the rate specified for the boards with lower load-bearing capacity (60kN/m²);**
- distance between the elements connecting the boards vertically should be approximately 60 cm.

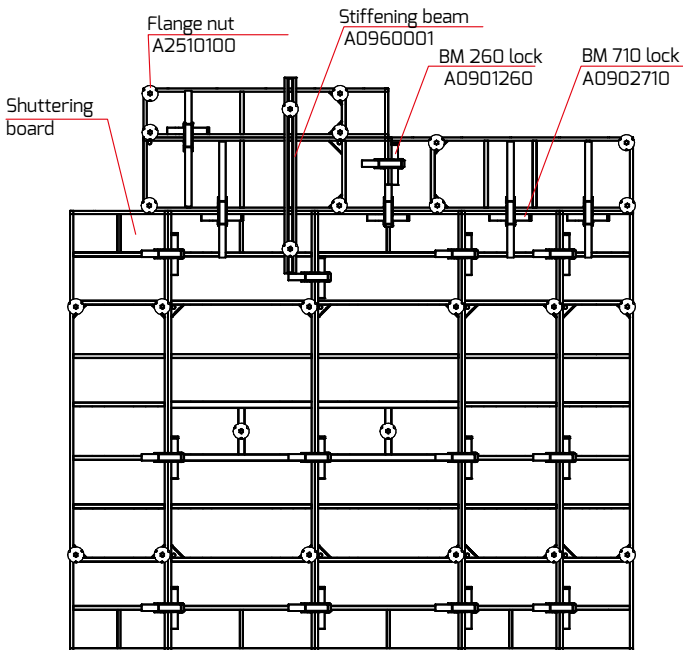

Fig. 3.6

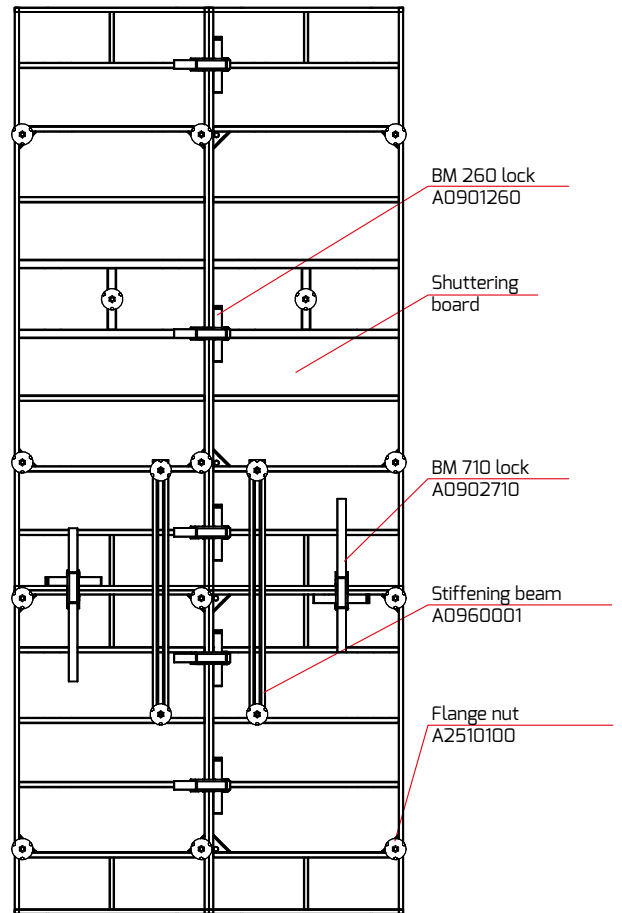

Fig. 3.7

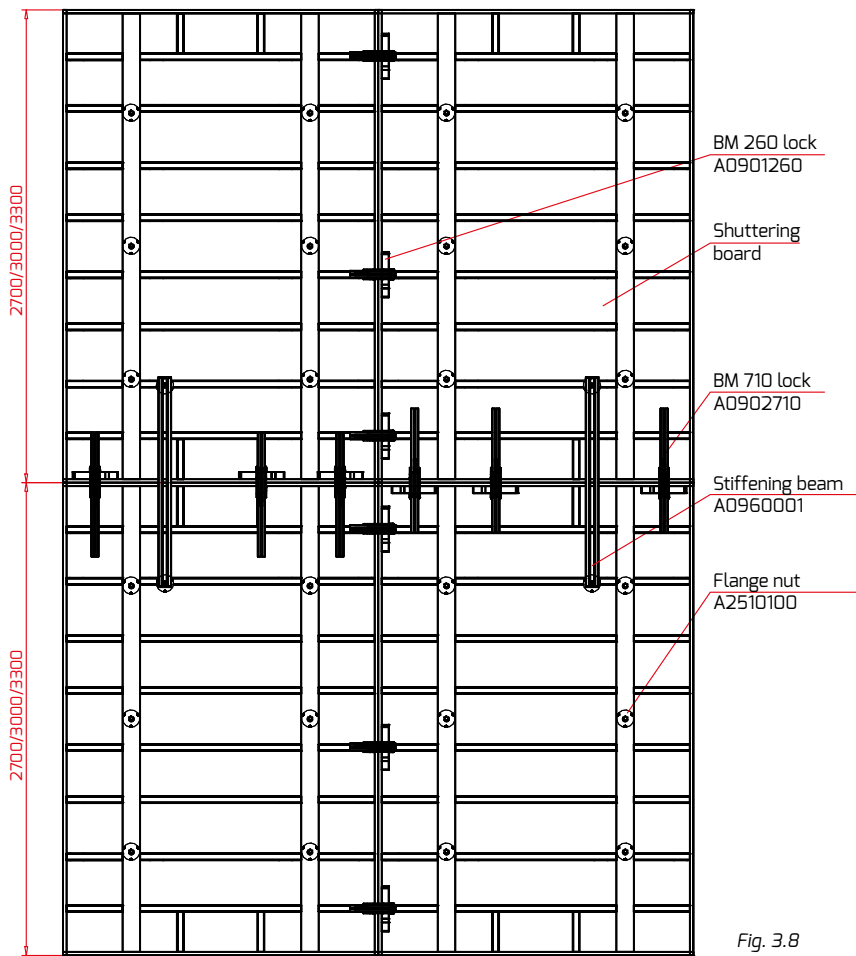

Fig. 3.8

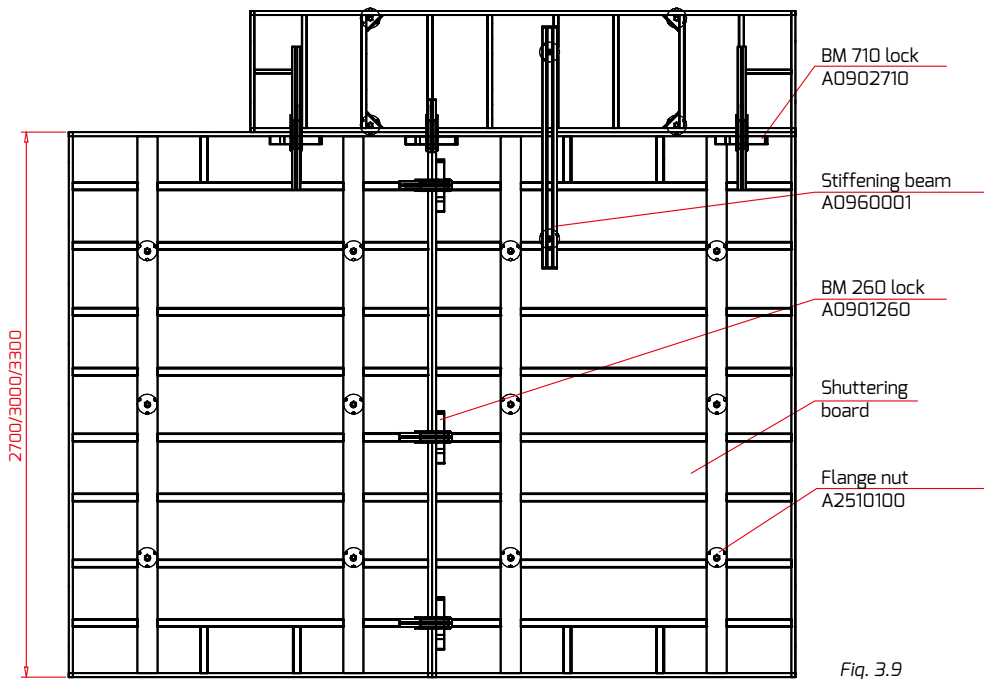

Fig. 3.9

In particular cases the boards can be connected vertically not necessarily in the structural crosspieces.

NOTE: the Assembly instructions do not replace the EHS instructions on the construction site!

The construction manager is responsible for the assembly of the formwork and checking if it is correctly assembled!

3.4. Walls with the superstructure bracket

The superstructure bracket 0,6 m - A0603600 (fig. 3.10) is an element that works together with all shuttering boards of the MIDI BOX system. By using this bracket the walls can be concreted 0,6 m higher.

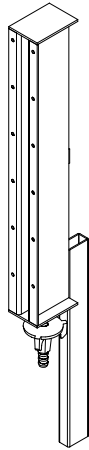

Fig. 3.10

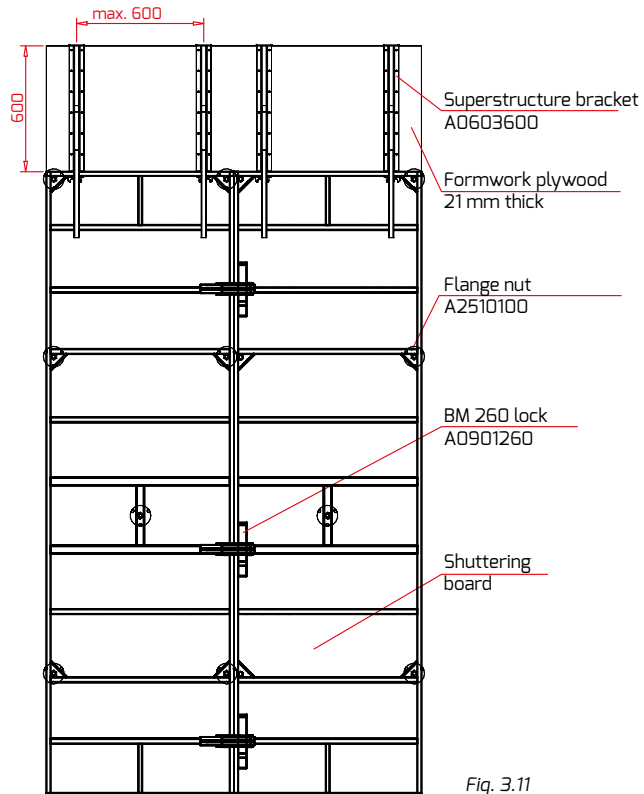

Fig. 3.11

The bracket is fastened to the external frames of the shuttering boards (oval hole 20 x 30) with the bowstring and the flange nut $\varnothing 70$ (fig. 3.12). It is filled with the formwork plywood 21 mm thick.

The maximum distance between the brackets should not be greater than 0,6 m and should be adjusted to the stiffness of plywood used.

The plywood is fixed to the bracket with nails or wood screws.

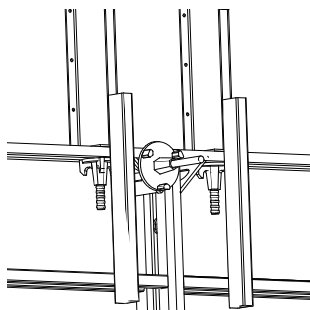

Fig. 3.12

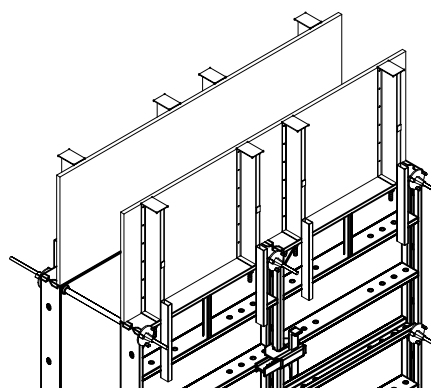

Fig. 3.13

The superstructure bracket increases the concreted wall height so you should determine the concreting rate appropriately.

3.5. Adjustment of the wall length when using the filling inserts

When the required formwork length cannot be obtained with the shuttering boards put the wooden or steel inserts between the boards.

ALTRAD-MOSTOSTAL offers the typical steel inserts 5 cm (A0605...) wide and the filling adjustable inserts (A0636...) used to compensate the formwork length within 7 ± 25 cm. When using the steel inserts the boards should be connected with the BM locks that allow to connect the inserts up to 12 cm long or the formwork transoms which stiffen the boarding and “press” the inserts (fig. 3.14).

When the inserts are smaller than 5 cm you should select planks or plywood with the appropriate width directly on the construction site and install these elements in the same manner as the filling inserts.

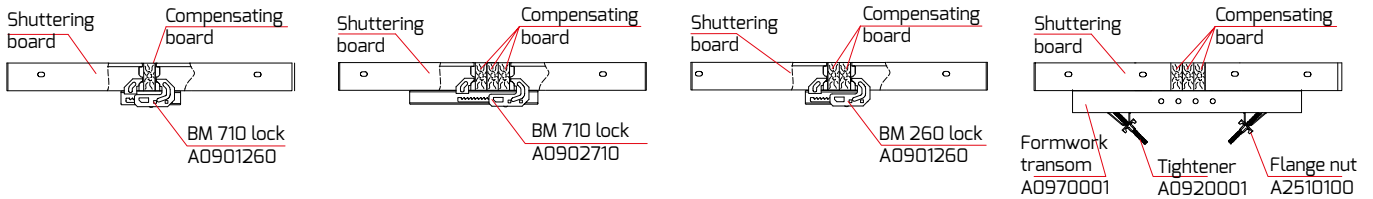

Fig. 3.14

Board height H [cm]	Number of locks in the board contact point	Number of bowstrings in the board contact point	Number of bowstrings in the board contact point
90	2	2	2
120	2	2	2
150	2	2	2
270	3	2	3
300	3	3	3
330	3	3	3

The filling adjustable inserts are installed with the bowstring and stiffening beams (rys 3.15).

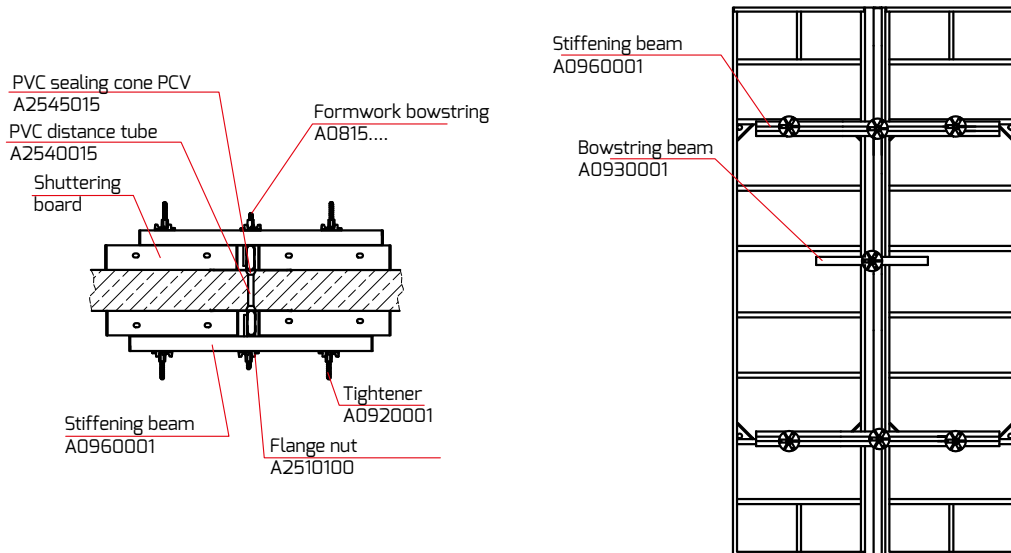

Fig. 3.15

Board height H [cm]	Quantity of connectors per insert – stiffening beam, tightener/nut	Number of bowstrings in the board contact point
150	2 / 4 / 4	2
270	2 / 4 / 4	2
300	3 / 6 / 6	3

NOTE: the Assembly instructions do not replace the EHS instructions on the construction site!

The construction manager is responsible for the assembly of the formwork and checking if it is correctly assembled!

3.6. Wall finishes

The standard solution that is used when finishing the walls includes the system shuttering boards and the external corners (A0515...). The assembly method is shown in fig. 3.16.

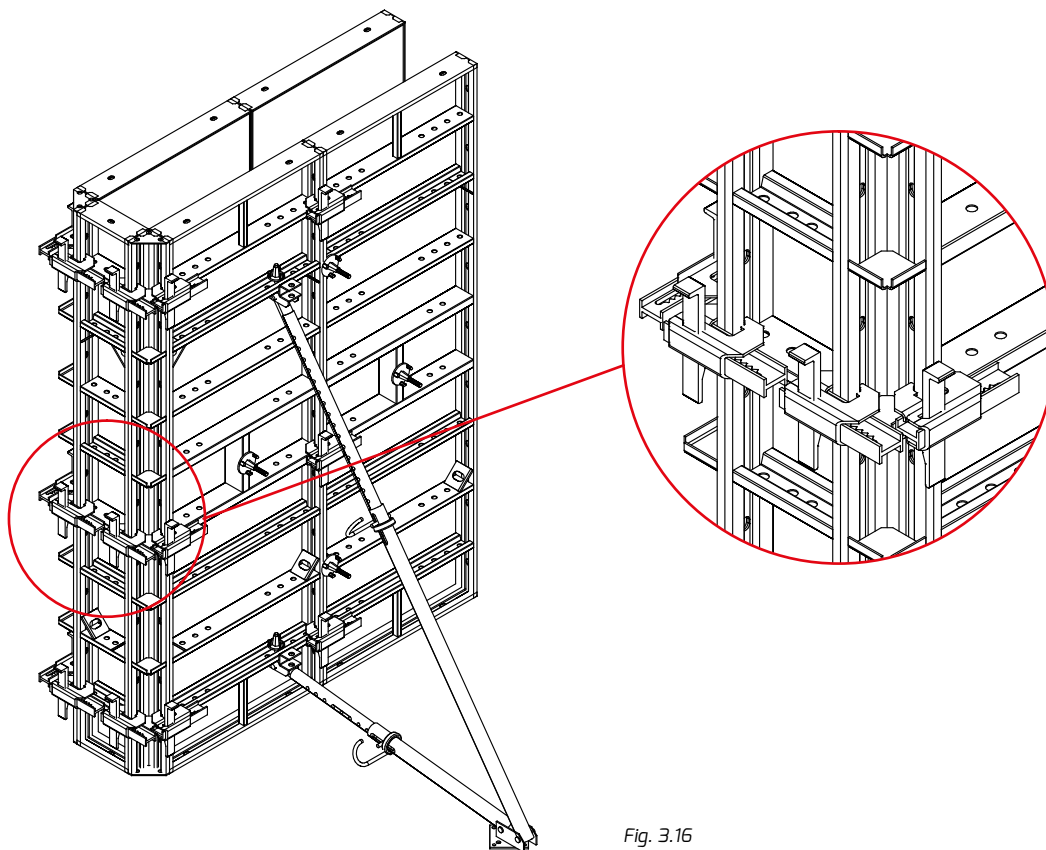

Fig. 3.16

Board height H (cm)	Number of locks	Number of bowstrings
90	8	0
120	8	0
150	8	0
270	12	0
300	12	0
330	12	0

The walls may also be finished by using several different methods such as:

- by using the tightening beams working together with the straight or centring bowstrings, nuts and plywood, and the construction timber (fig. 3.17);
- by using only the centring bowstrings and plywood, and timber (fig. 3.18);
- by using the edge catches, straight bowstrings, nuts and plywood, and timber (fig. 3.19);
- by using the bowstrings, nuts and timber with plywood along with using the structural holes provided in the boards (fig. 3.20).

The solutions presented are based on the system elements which are recommended by the producer and do not limit any other solutions that may be used or the possibility to mix the elements specified above.

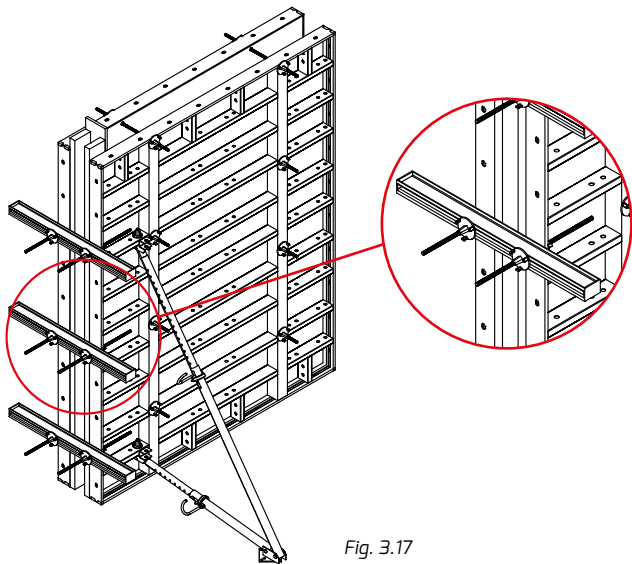

Fig. 3.17

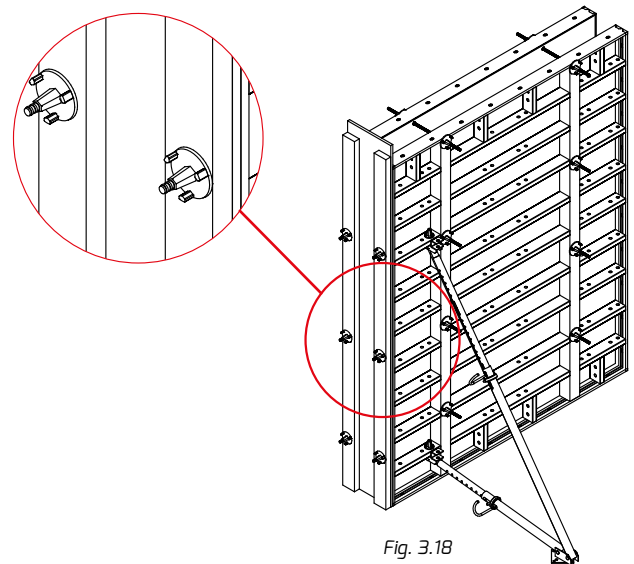

Fig. 3.18

Board height H (cm)	Number of nuts	Number of bowstrings	Number of transoms
90	8	4	2
120	8	4	2
150	8	4	2
270	12	6	3
300	12	6	3
330	12	6	3

Board height H (cm)	Number of nuts	Number of centring bowstrings
90	4	4
120	4	4
150	4	4
270	6	6
300	6	6
330	6	6

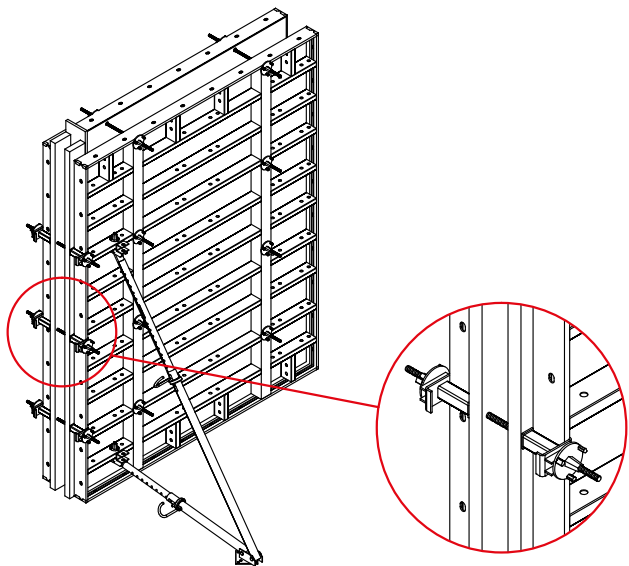

Fig. 3.19

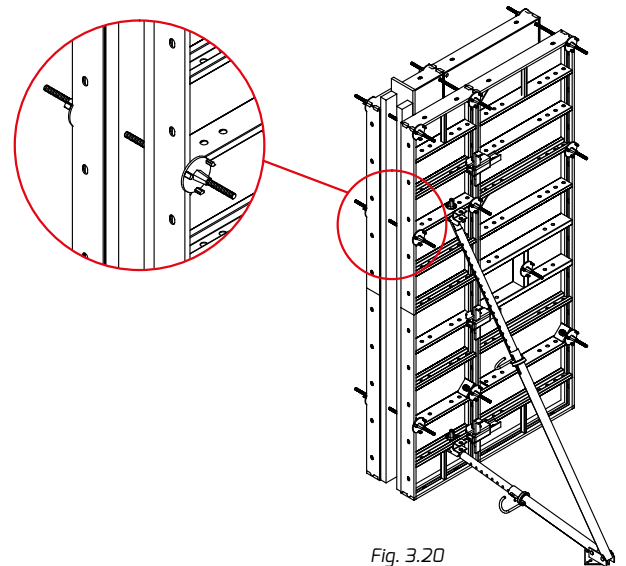

Fig. 3.20

Board height H (cm)	Number of nuts	Number of bowstrings	Number of transoms
90	4	2	4
120	4	2	4
150	4	2	4
270	6	3	6
300	6	3	6
330	6	3	6

Board height H (cm)	Number of nuts	Number of centring bowstrings
90	4	2
120	4	2
150	4	2
270	6	3
300	6	3
330	6	3

NOTE: the Assembly instructions do not replace the EHS instructions on the construction site!

The construction manager is responsible for the assembly of the formwork and checking if it is correctly assembled!

3.7. Forming when the wall thickness is changed

a) Changing the thickness by G up to 10 cm

Wooden insert thickness: $D = 12 \text{ cm} - G \text{ [cm]}$

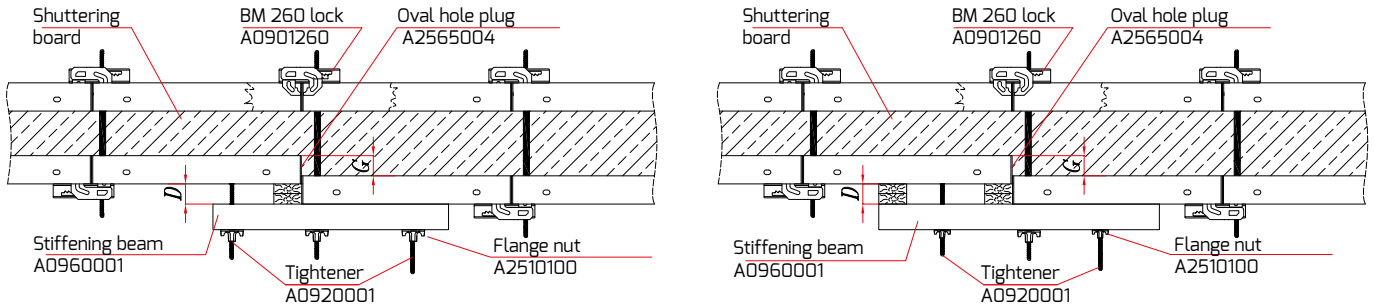

Fig. 3.21

 When the wall thickness changes by more than 5 cm install the oval hole plugs in the wall narrowing board frame to protect concrete from leaking through the frame holes.

b) Changing the thickness by $G = 1 \div 18 \text{ cm}$.

Wooden insert thickness: $D = 30 - (G + 12) \text{ [cm]}$

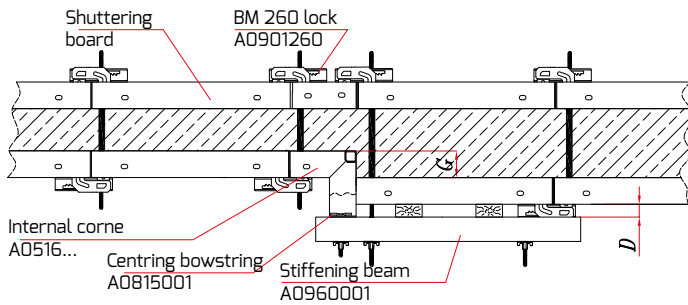

Fig. 3.22

c) Changing the thickness by $G = 30 \text{ lub } 15 \text{ cm}$

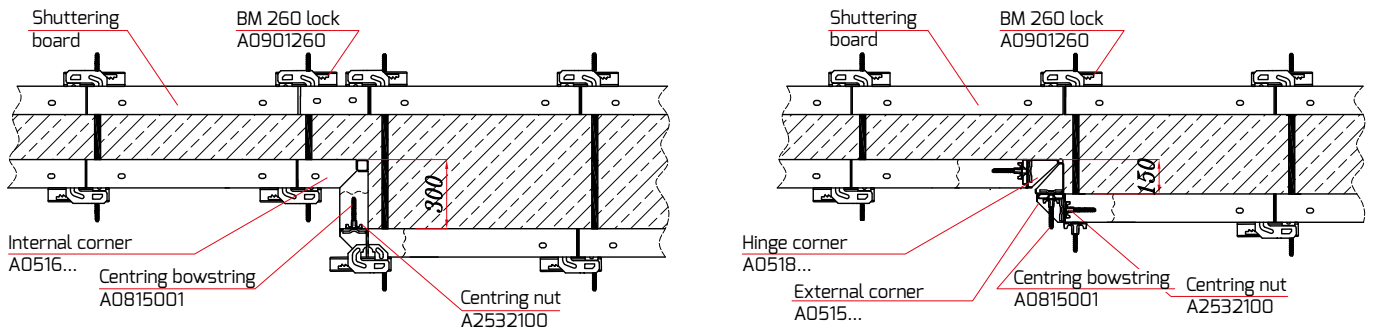

Fig. 3.23

3.8. Working platforms

The inspection platforms should be erected with the brackets A0951000 which are fixed in the shuttering board holes and act as a base on which the wooden planks can be easily installed to form a platform. Overlap of wooden planks or platforms relative to the axis not less than 250mm each side. It is recommended to secure them against displacement (e.g. nailing). The possibility to instal the posts A0970002, railings and toeboards ensures the completely safe tasks completion by the employees.

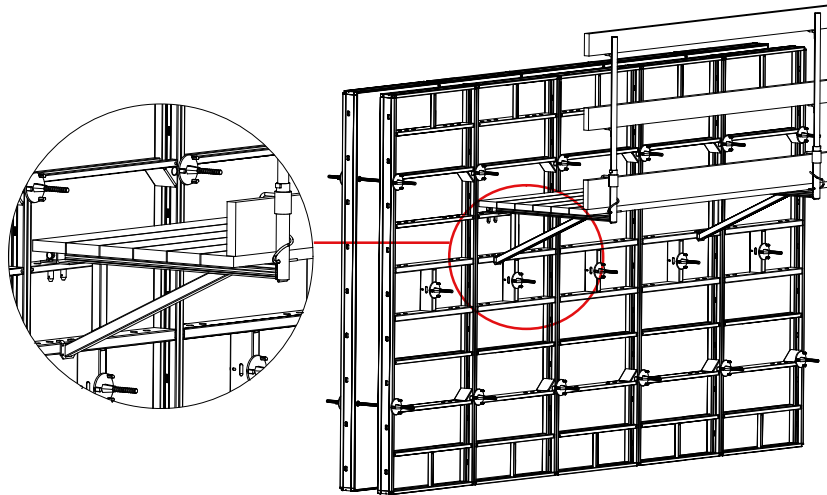

Fig. 3.24 – Sample installed working platform

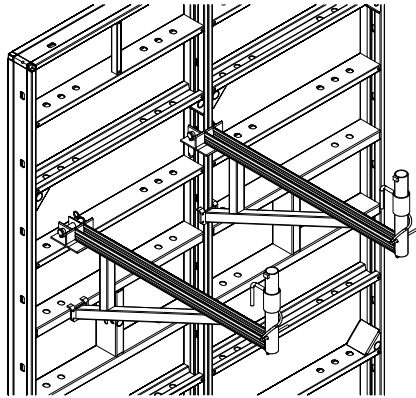

Fig. 3.25 – Sample method of installation of the working platform on the formwork

Maximum distance between working platforms brackets up to 2m, depends on decking elements (wooden planks or platforms). Permissible operational load of the inspection platform 1,5k N/sq.m.

Span limits of the wooden or planks platforms (acc. To tab. 8, DIN 4420, T1)					
Loading group	Width of platform or plank [cm]	Thickness of platform or plank [cm]			
		3.0	3.5	4.0	4.5
2 (1.5 kN/m ²)	20÷28	1.25	1.50	1.75	2.00

NOTE: the Assembly instructions do not replace the EHS instructions on the construction site!

The construction manager is responsible for the assembly of the formwork and checking if it is correctly assembled!

3.9. Transporting the elements on the construction site

The horizontal transportation catch is used to transport the boards horizontally.

Hook – a device fitted on the shuttering boards to transport the single boards or the complete formwork segments. Fig. 3.27 and 3.28 present the sequence of installation of a single hook on the shuttering board. Fig. 3.29 presents the formwork segment transportation method by using the hooks (A0908000). There are separate operation and use manual for hooks - IT-29.

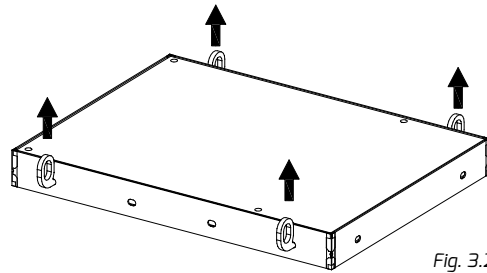

Fig. 3.26

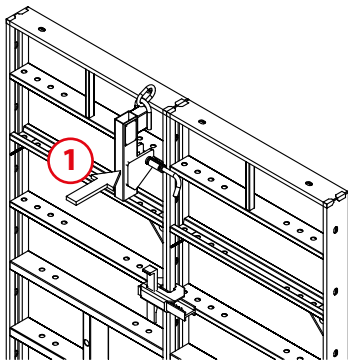

Fig. 3.27

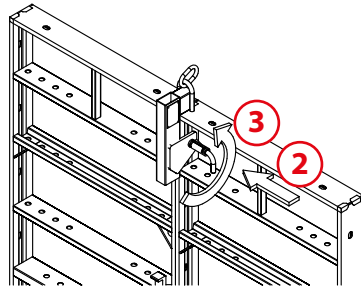

Fig. 3.28

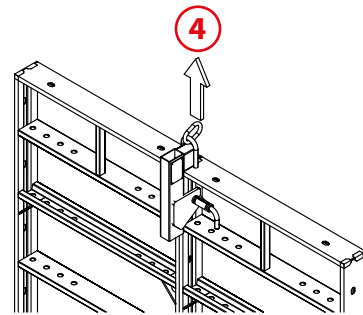

Fig. 3.29

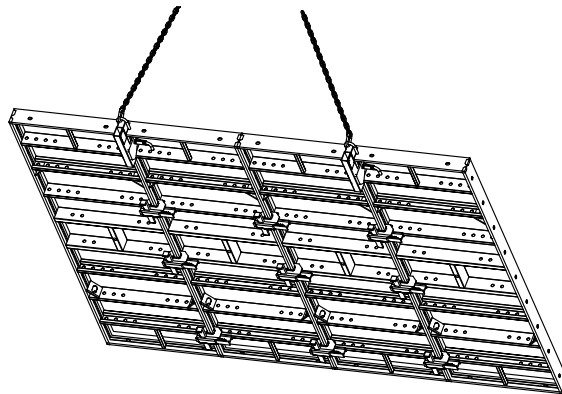

Fig. 3.30

Fig. 3.31 present the transportation sling (A0909001) installation method. By using this sling you can quickly and efficiently transport the single shuttering boards. The transport sling with the pressure spring is used to transport individual formwork boards quickly and efficiently. There are separate operation and use manual for transportation slings - IT-37.

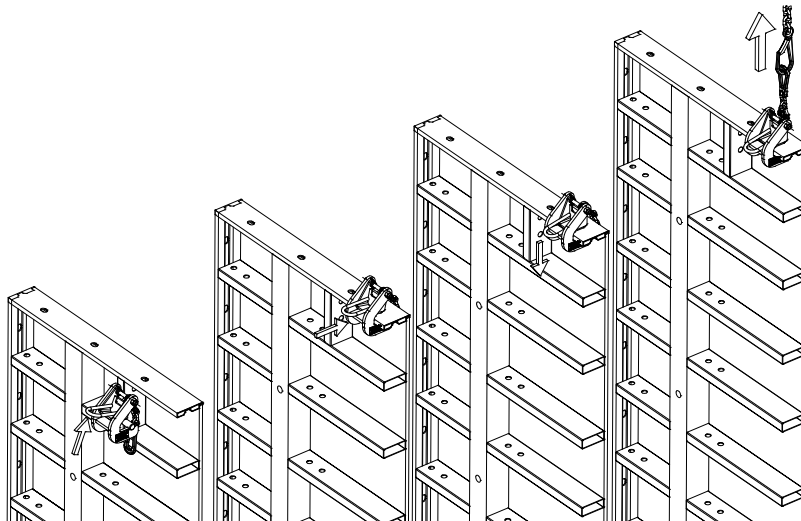

Fig. 3.31

4. CORNERS

4.1. Internal corners

The rectangular internal corners are made by inserting the internal corner 30 x 30 cm (fig. 4.1 and fig. 4.1b). The corners with the following heights are available: 90, 120, 150, 270, 300 and 330 cm. The corner is connected with the shuttering boards with the BM 260 locks and the centring bowstrings as well as the centring nuts - one corner side is "clamped" with the locks and the other side is tightened with the bowstrings and centring nuts (fig. 4.1a). It is acceptable to connect the corner with the shuttering boards only by using the BM 260 locks (fig. 4.1b).

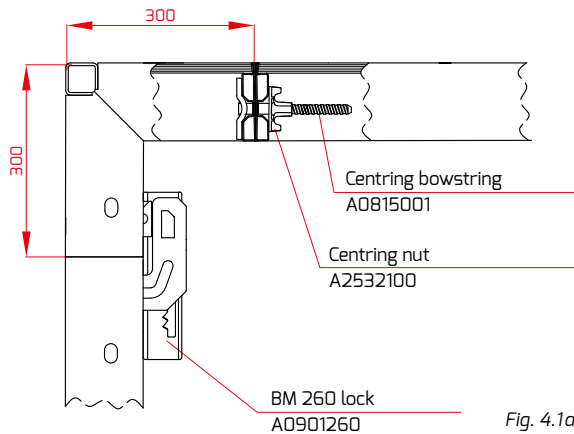

Fig. 4.1a

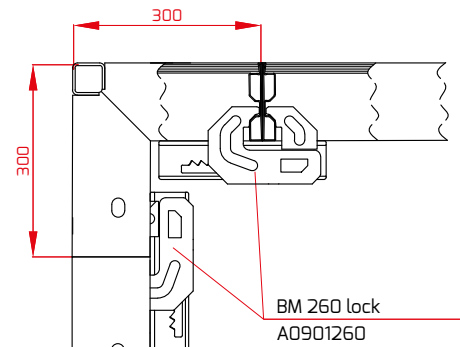

Fig. 4.1b

Board height H [cm]	Number of locks	Number of centring bowstrings
90	2	2
120	2	2
150	2	2
270	3	3
300	3	3
330	3	3

It is also acceptable to use the hinge corners. The hinge corner 30 x 30 x H (H = 90, 120, 150, 270, 300 or 330) is connected in the same manner as the internal corner. However, the hinge corner 15 x 15 x H (H = 90, 120, 150, 270, 300 or 330 cm) is connected only by using the centring bowstring and the centring nuts by tightening the sides of the corner and the shuttering boards. The required number of bowstrings equals to the number of locks determined above.

4.2. External corners

The simplest and at the same time the most efficient method of boarding of the external corner includes using the zero corner. This corner is connected with the shuttering boards by using the BM 260 locks on one side of the corner and centring bowstrings with the centring nut on the other corner side. It is also possible to connect the corner with the shuttering boards only by using the BM 260 locks.

Board height H [cm]	Number of locks	Number of centring bowstrings
90	3	3
120	3	3
150	4	4
270	5	5
300	6	6
330	6	6

NOTE: the Assembly instructions do not replace the EHS instructions on the construction site!

The construction manager is responsible for the assembly of the formwork and checking if it is correctly assembled!

The width of the closing board is calculated as follows:

$$S \text{ (external board width)} = \text{internal corner width} + \text{wall thickness}$$

Below are the sample zero corner applications (fig. 4.2 i 4.3).

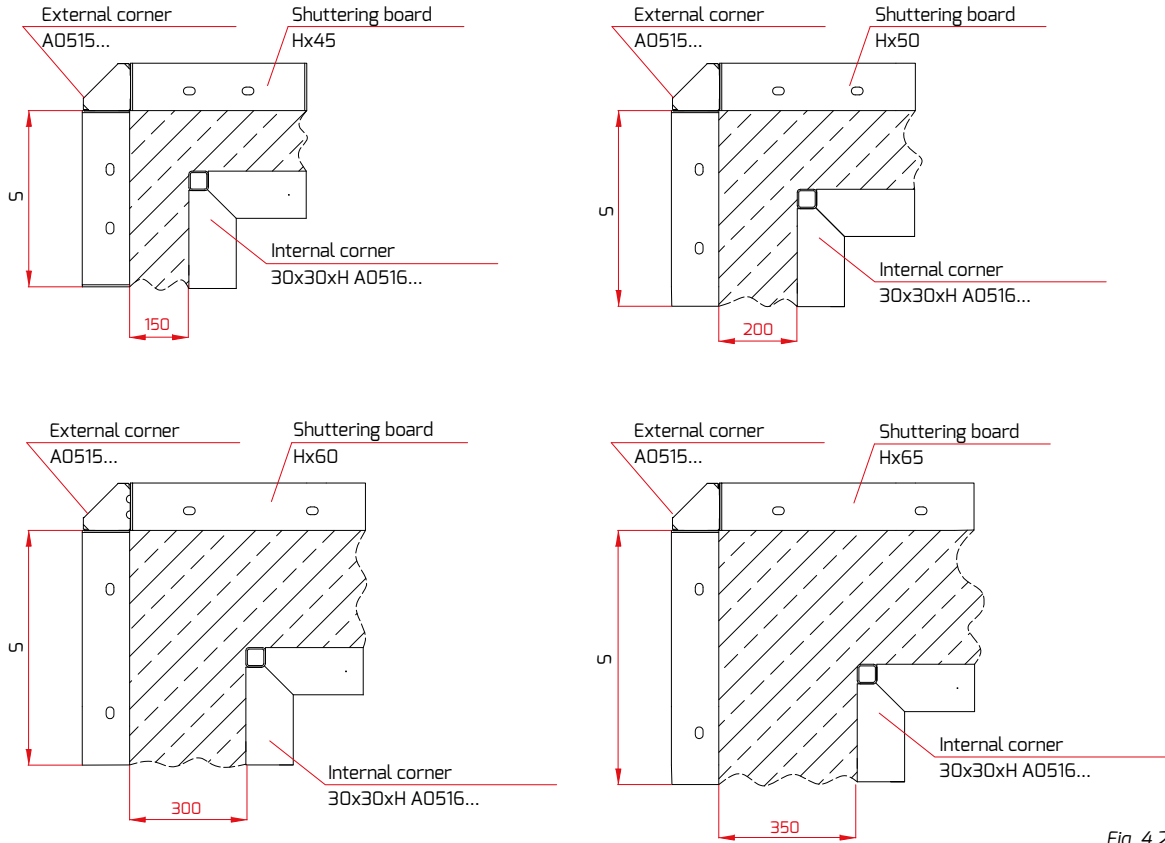

Fig. 4.2

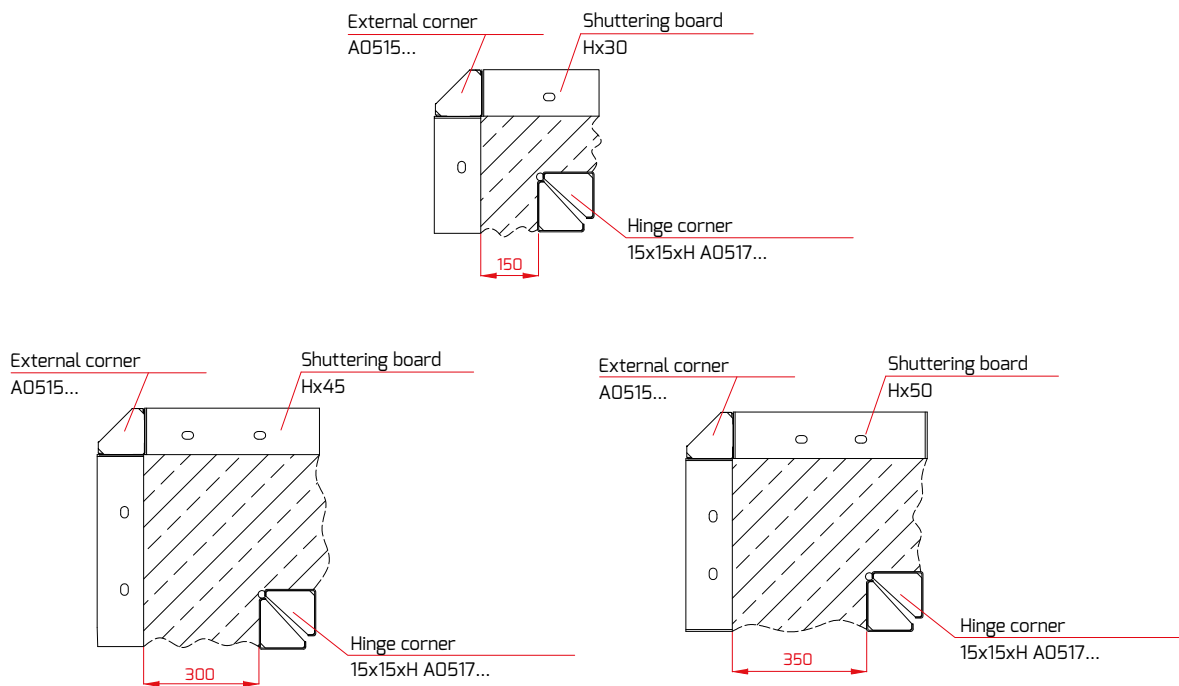

Fig. 4.3

Alternatively, the rectangular external corners may be formed by using the corner lock. This solution does not require any external corners. Two formwork bars at a right angle are joined only with the corner formwork locks. To join the boards correctly you must position one board in relation to the other so that the overlap by 121 mm which is the thickness of the formwork boards. Install the locks at the height corresponding to the height of the horizontal crossbars are immediately close to them.

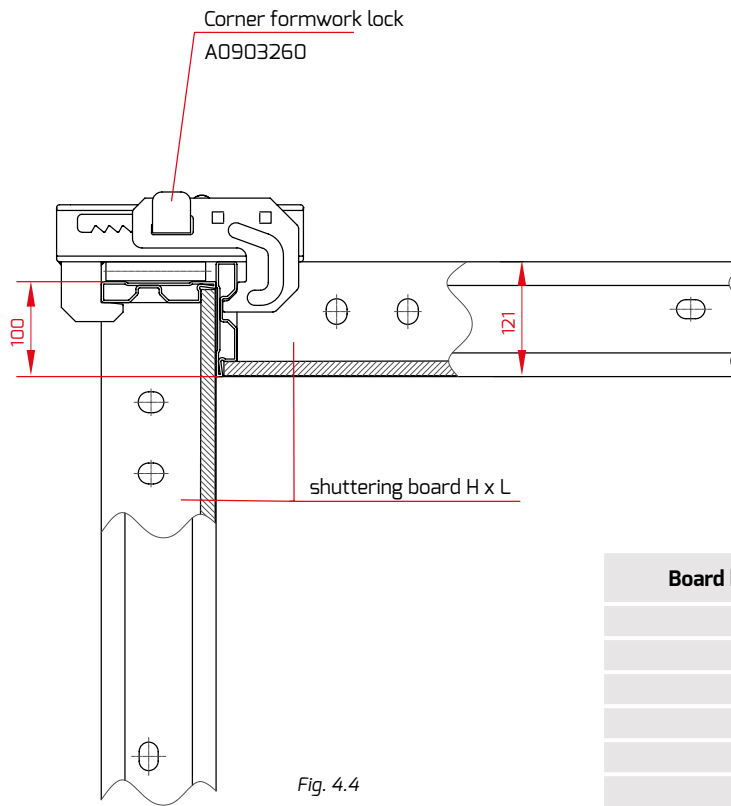
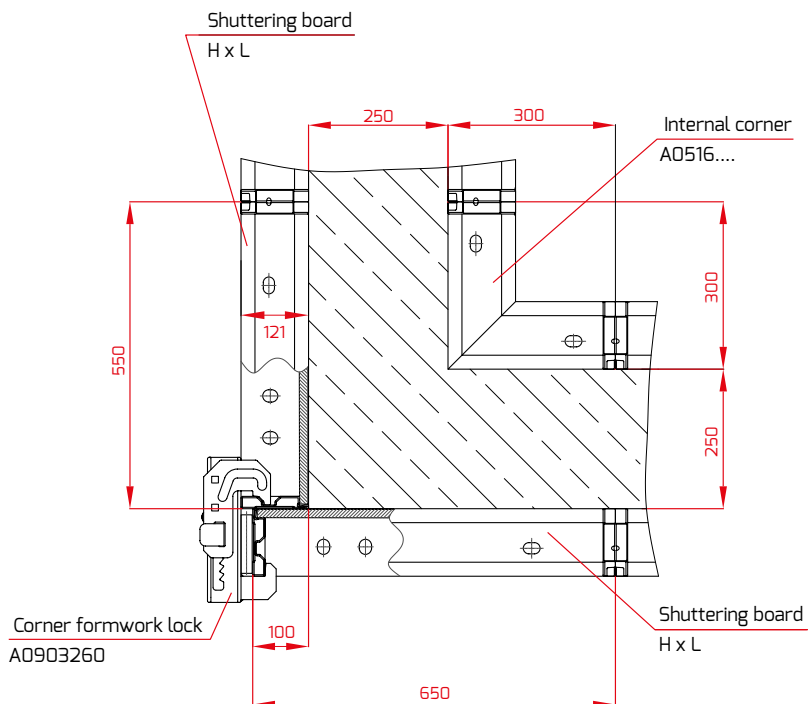

Fig. 4.4

Board height H [cm]	Quantity of corner locks
90	3
120	3
150	4
270	5
300	5
330	6

An example of using a corner lock is shown below.



NOTE: the Assembly instructions do not replace the EHS instructions on the construction site!
The construction manager is responsible for the assembly of the formwork and checking if it is correctly assembled!

4.3. Obtuse and acute angle corners

The obtuse and acute angle corners are formed with the hinge corners 30 x 30 and 15 x 15. The corners 15 x 15 can be drawn aside or folded within $90^\circ \div 210^\circ$ and the corners 30 x 30 can be used within $60^\circ \div 270^\circ$. The hinge corners 15 x 15 are connected with the shuttering boards with the centring bowstrings and the centring nuts. When installing the internal corner it is connected in three points (height of 90, 120, 150, 270, 300 and 330 cm) and on the external side the corners are connected with: $h = 90, 120, 150 \text{ cm} - 3 \text{ bowstrings}$; $h = 270, 300 \text{ and } 330 \text{ cm} = 5 \text{ bowstrings}$.

When installing the shuttering boards of two different heights e.g. 150 cm and 270 cm the shorter boards should be installed at the formwork bottom. The levels of the boards should be connected with the centring bowstrings or the formwork locks.

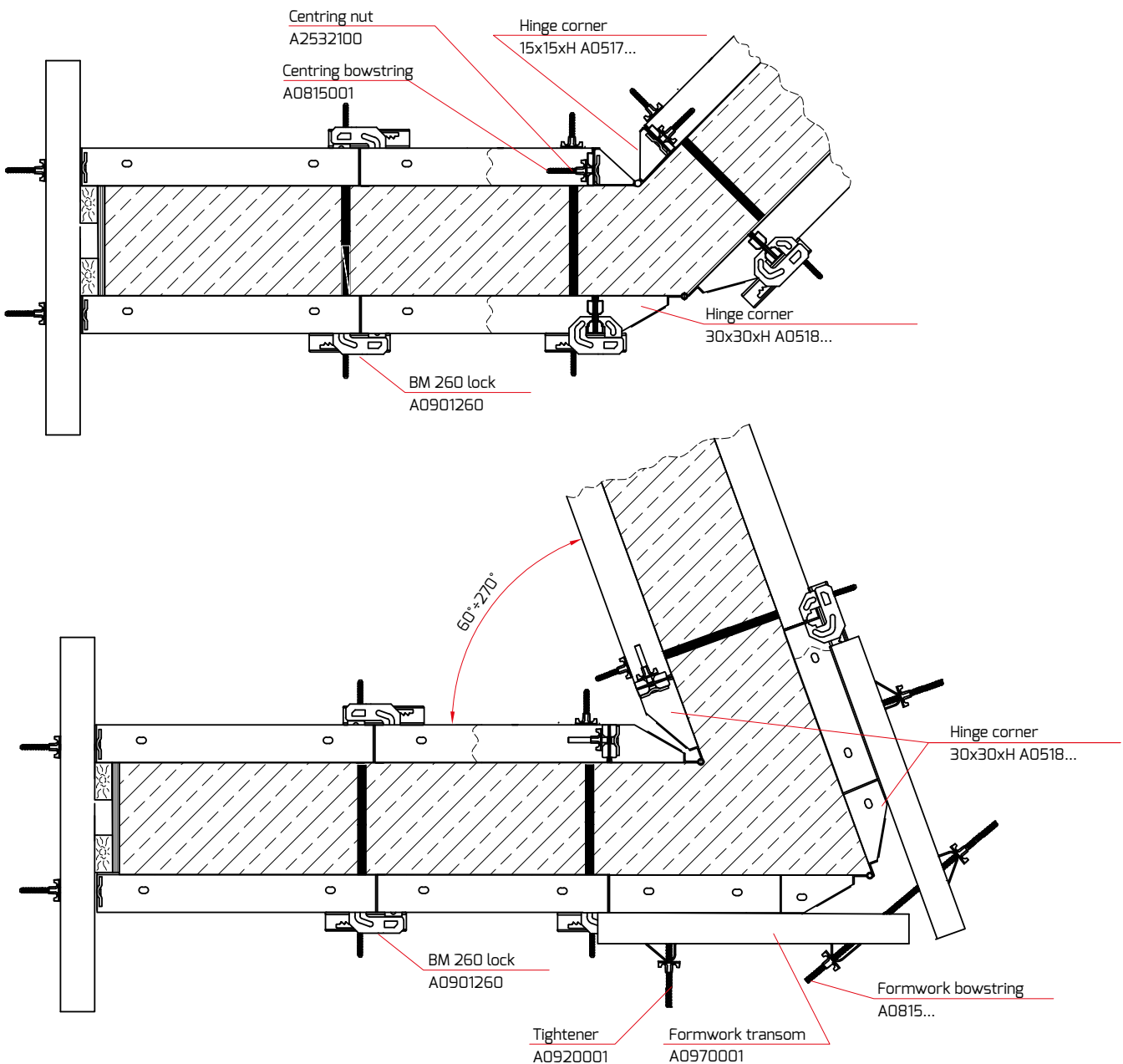

Fig. 4.5

5. HIGH WALL FORMING CLIMBING FORMWORK

The climbing formwork is the type of the wall formwork that is used for boarding of the external walls. The climbing formwork bracket is the basic set element. The calculations for the brackets were made according to the Polish Standards and the bracket withstand the wind load up to the height of $H = 100$ m without any additional anchoring of the boards 4,2 m. high. The maximum brackets spacing = 1,35 m. The brackets should be anchored with the SKK cones and B15 waved or loop anchors. The cone is a recoverable element.

Due to the diversity of the MIDI BOX boards it is possible to optimally position any formwork. Both systems ensure that the surfaces obtained are smooth and do not have to be plastered when the formwork is removed. Only thin-layer plasters or patching can be used.

5.1. SKK cone assembly



Anchors spacing, length, type and the anchor installation method can be determined individually each time according to the building static requirements.

5.1.1. Fastening the SKK cones to the shuttering board

The works start from calculating the “ordinate” of the cone fastening line on the formwork where “0” is the level of the last ceiling. The calculations are made as follows:

$$h = h_s - g_s - 10 \text{ cm} - x$$

where:

h – SKK cone position height from the “0” level; [cm]

h_s – wall height; [cm]

g_s – ceiling thickness; [cm]

x – sleeper thickness (e.g. square timber 10 x 10, H-20 wooden girder etc.), the sleeper is propped on the climbing bracket catches and serves as a prop for the shuttering boards; [cm]

When the cone line height is calculated the points where the M24 installation grips must be nailed should be marked on the external formwork and these grips should be installed. Then, screw the SKK cone in the grip installed and screw the appropriate anchor in the cone. The type and length of the anchor depend on the place where the cone is positioned (wall, ceiling) and the process concrete hardening time. This is the time calculated from the moment the cones are concreted to the moment the climbing formwork brackets are installed in these cones.

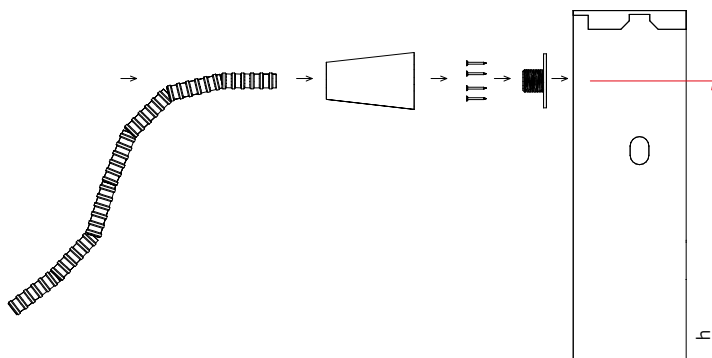

Fig. 5.1

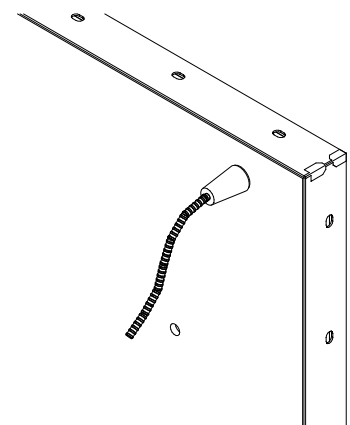

Fig. 5.2

NOTE: the Assembly instructions do not replace the EHS instructions on the construction site!

The construction manager is responsible for the assembly of the formwork and checking if it is correctly assembled!

5.1.2. Fastening of the anchor to the reinforced concrete structure – manners

• Fastening the SKK cone to the wall

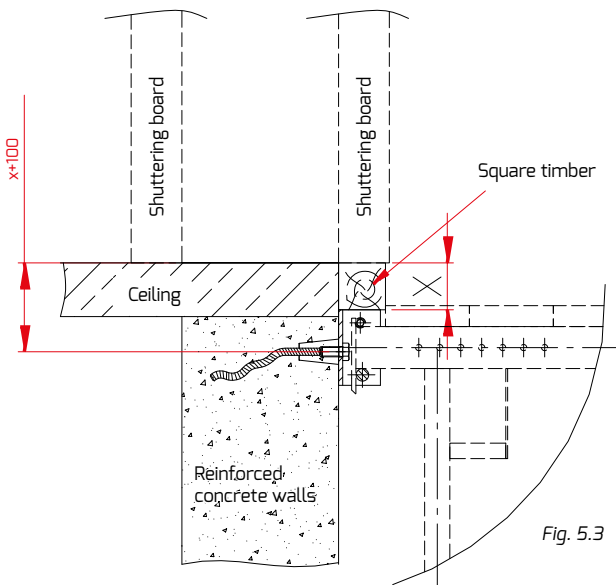

Fig. 5.3

This solution is used with the prefabricated ceilings and when the ceiling is less than 150 mm thick. Depending on the wall thickness you should use the hook anchors or waved anchors with the D15 thread. It is recommended to connect the anchors with the wall reinforcement by using the conventional welding method.

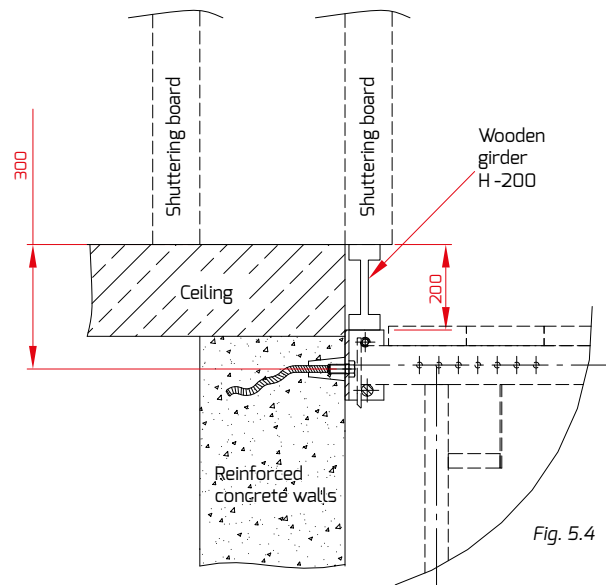

Fig. 5.4

This solution is used with the prefabricated ceilings and when the ceiling is less than 250 mm thick. Depending on the wall thickness you should use the hook anchors or waved anchors with the D15 thread. It is recommended to connect the anchors with the wall reinforcement by using the conventional welding method.

• Fastening SKK cone to ceiling

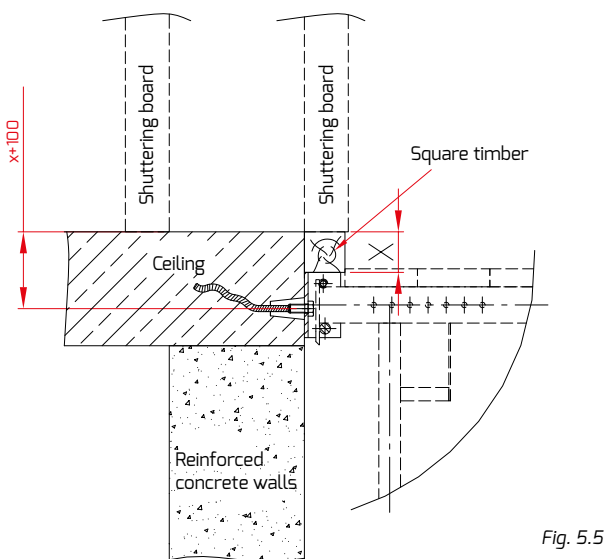

Fig. 5.5

This solution is used with the monolithic ceilings which are more than 250 mm thick. It is recommended to use the waved anchors welded to the ceiling reinforcement.

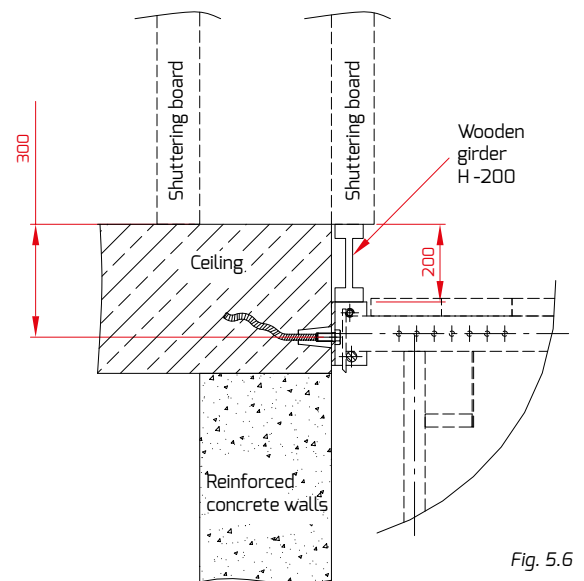

Fig. 5.6

This solution is used with the monolithic ceilings which are more than 350 mm thick. It is recommended to use the waved anchors welded to the ceiling reinforcement.

- Fixing the SKK cone on the ceiling bottom surface

When the ceiling thickness exceeds the thickness of the square timber or girder thickness by 100 mm it is acceptable to fix the SKK cone on the wall and monolithic ceiling contact surface. The waved anchor should be welded to the ceiling reinforcement.

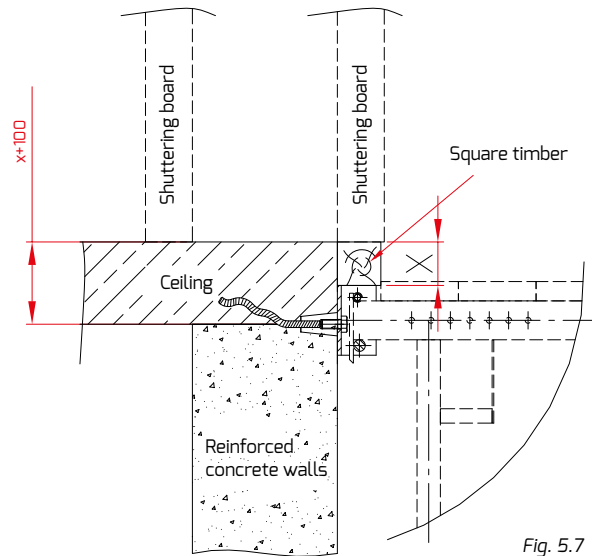

Fig. 5.7

5.2. Wall bracket assembly

Preparing the “transportation segment”

Two climbing formwork brackets (A0915003) are placed parallel to each other at a distance which results from the SKK cones spacing after concreting them in the building structure - maximum spacing is 135 cm. The standard pipes (3 pcs.) are installed in the clamps. By using the rotary couplings screw in the diagonal from the standard pipe Ø48,3. The wall bracket beams are fitted with the tilting prop grip (A0915005) and the working platform posts (A0970002). The posts are covered with the protective planks (A0920005) and the working platform toeboard (A0920004). Then put the H-200 wooden girders of the length of e.g. 245 cm on the shelves of the climbing formwork bracket. The transportation segment assembled in this manner is connected with the 4-hook sling of the crane and lifted so high that it is possible to insert the auxiliary platform bracket (A0952000) in the climbing formwork bracket section.

Both brackets are connected with two pins. The “pair” of the auxiliary platform brackets is fitted with the protective planks and the climbing formwork auxiliary platform (A0920006).



When the climbing formwork brackets are installed for the first time it is not necessary to use the auxiliary platform brackets. They can be used only when the “transportation segment” is moved upwards for the first time.

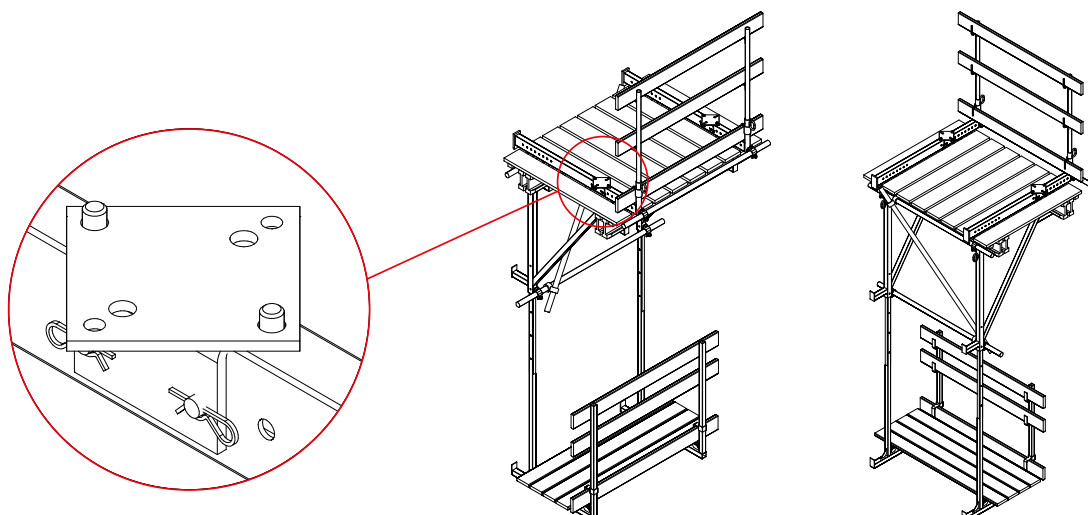

Fig. 5.8

NOTE: the Assembly instructions do not replace the EHS instructions on the construction site!

The construction manager is responsible for the assembly of the formwork and checking if it is correctly assembled!

5.3. Assembly of the climbing formwork bracket catches

After removing the formwork where the SKK cones (A2545030) are concreted remove the M24 installation grips (A2545040) from the SKK cones. Instead of the grip that has been removed screw on the climbing formwork bracket catch (A0915004) by using the special M24 x 45 screw.

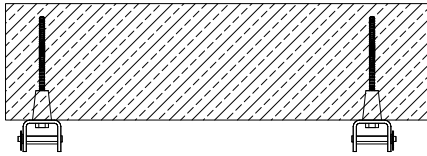

Fig. 5.9

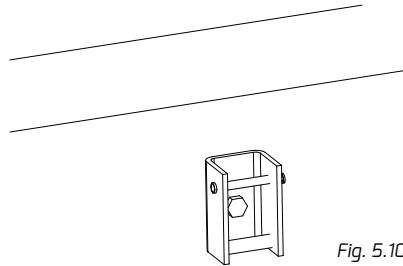

Fig. 5.10

The climbing formwork bracket catches and the SKK cones are removed from the auxiliary platform. To remove the SKK cone you should use an appropriate spanner.

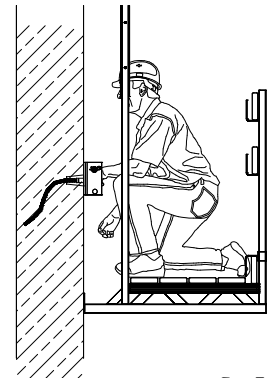

Fig. 5.11

5.4. Assembly of the transportation segments on the building structure

When the bracket catches (A0915004) are installed in the SKK cones the assembled transportation segments are moved with the crane. The transportation slings should be long enough to move the transportation segment "vertically". Figure 5.12 presents the climbing formwork bracket which was correctly assembled.

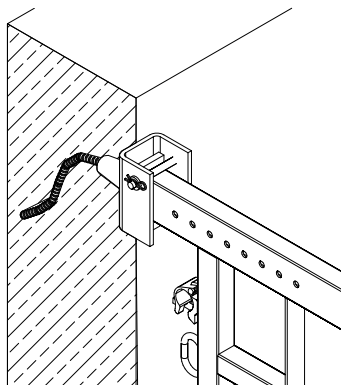

Fig. 5.12

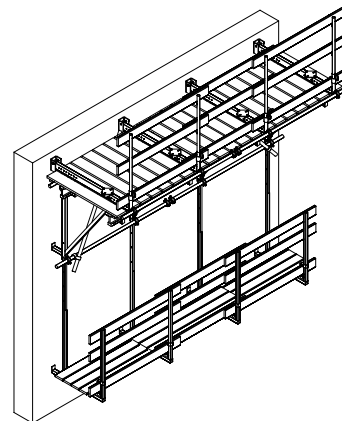

Fig. 5.13

The transportation segments are suspended systematically in every other bay. When the segments are installed expand the wooden girders placed previously on the bracket shelves so that the free bays between the segments are filled. To avoid the possible movement of the girders nail them to the bracket frame. Lay the platforms on the girders between the climbing formwork brackets. In this manner all bays between the transportation segments are filled with the platforms. Supplement also the protective planks installing them in the working platform post girders. Connect the standard pipes of the adjacent transportation segments with the longitudinal coupling (E581419). There is no need to install the additional bracings in the bays between the transportation segments.

5.5. Installing the wall formwork on the brackets

Position the shuttering boards on the climbing formwork which has been correctly assembled. These boards are propped on the sleepers prepared previously (square timbers or H-200 girders) of the assumed x thickness. The shuttering boards are plumbed by using the tilting props installed in the system board crosspiece holes and in the prop grip provided on the climbing formwork horizontal beam. The shuttering boards on the internal side are positioned on the ceiling and connected with the external boards by using the formwork bowstrings and the flange nuts.

It is possible to fasten the working platform to the shuttering board structure. This platform consists of the working platform brackets, working platform post and wooden elements which act as a platform as well as the protective elements.

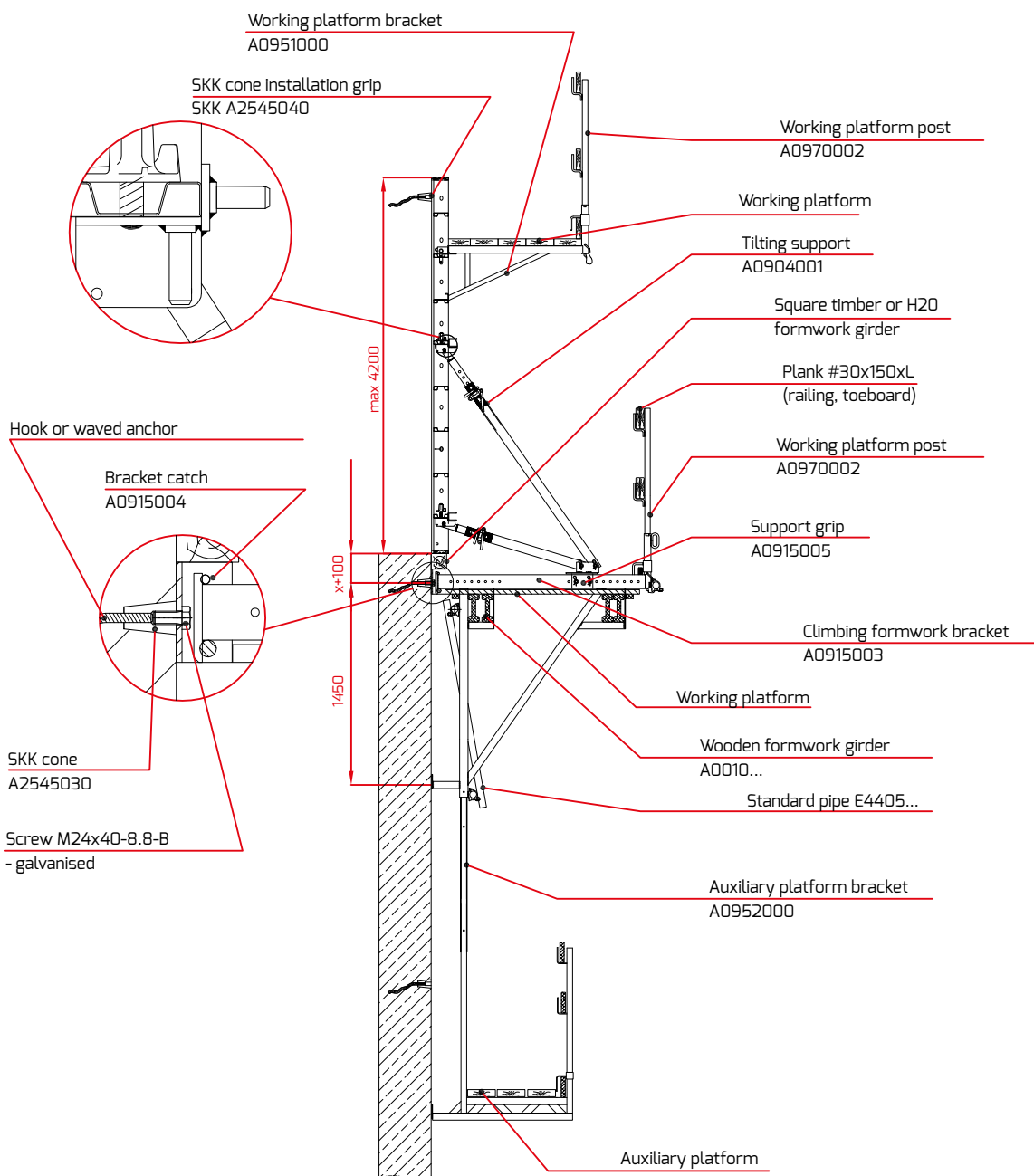

The climbing formwork is disassembled by completing its installation procedure in the reverse order.

NOTE: the Assembly instructions do not replace the EHS instructions on the construction site!

The construction manager is responsible for the assembly of the formwork and checking if it is correctly assembled!

6. POST FORMING

6.1. Forming the posts by using the zero corner and the (normal) shuttering boards

When the SP shuttering boards used for boarding of the posts in the module repositioned every 5 cm are missing the posts with the side of 25, 30, 45, 50, 55, 60, 65, 75 and 90 cm can be boarded by using the zero corners and normal shuttering boards – examples in (fig. 6.1).

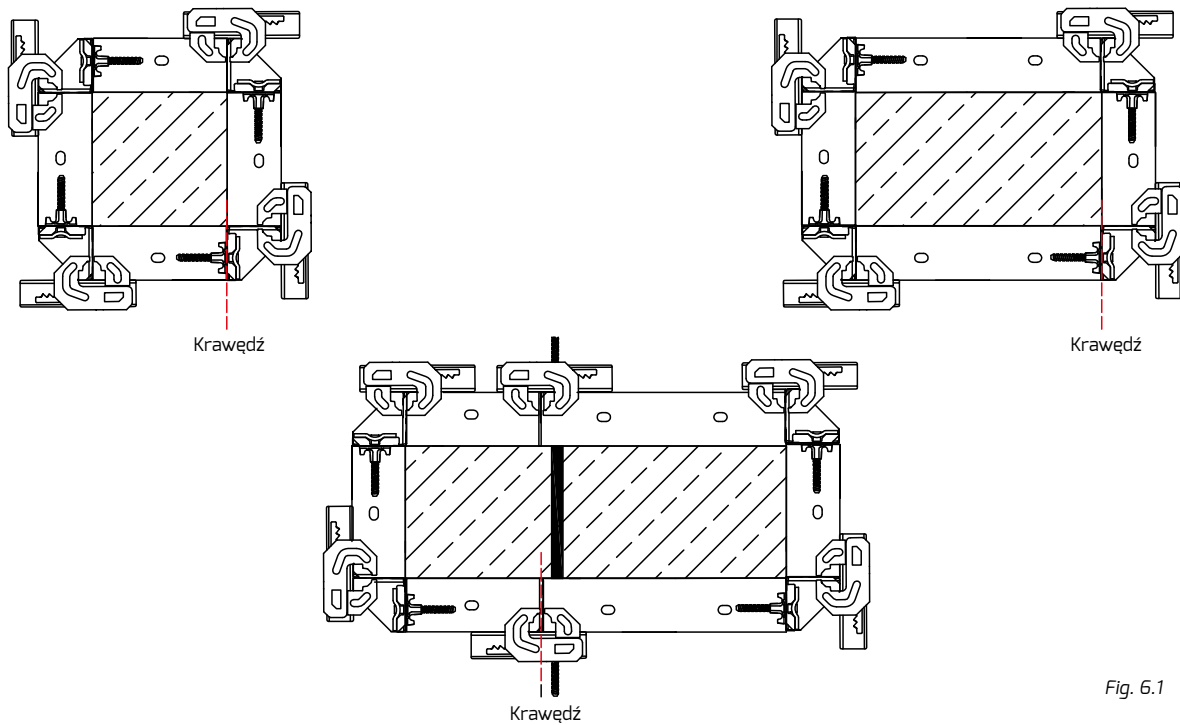

Fig. 6.1

The table below presents the selection of the number of centring bowstrings or BM 260 locks per one post edge depending of the height of the post (fig. 6.2).

		Number of locks / bowstrings	
		height [cm]	horizontally BM 260/ bowstrings
single boards	90	3	—
	120	3	—
	150	4	—
	270	5	—
	300	5	—
	330	6	—
board connections	Hs 300 (Hp150 + Hp150)	8	2
	Hs 420 (Hp150 + Hp270)	9	2
	Hs 540 (Hp270 + Hp270)	10	2

Hs - post height
Hp - board height

As regards the posts where the total height is obtained by positioning at least two boards vertically (e.g. Hs 300 = Hp 150 + Hp 150) the vertical board contact points are connected with at least one BM 710 lock installed on each post side.

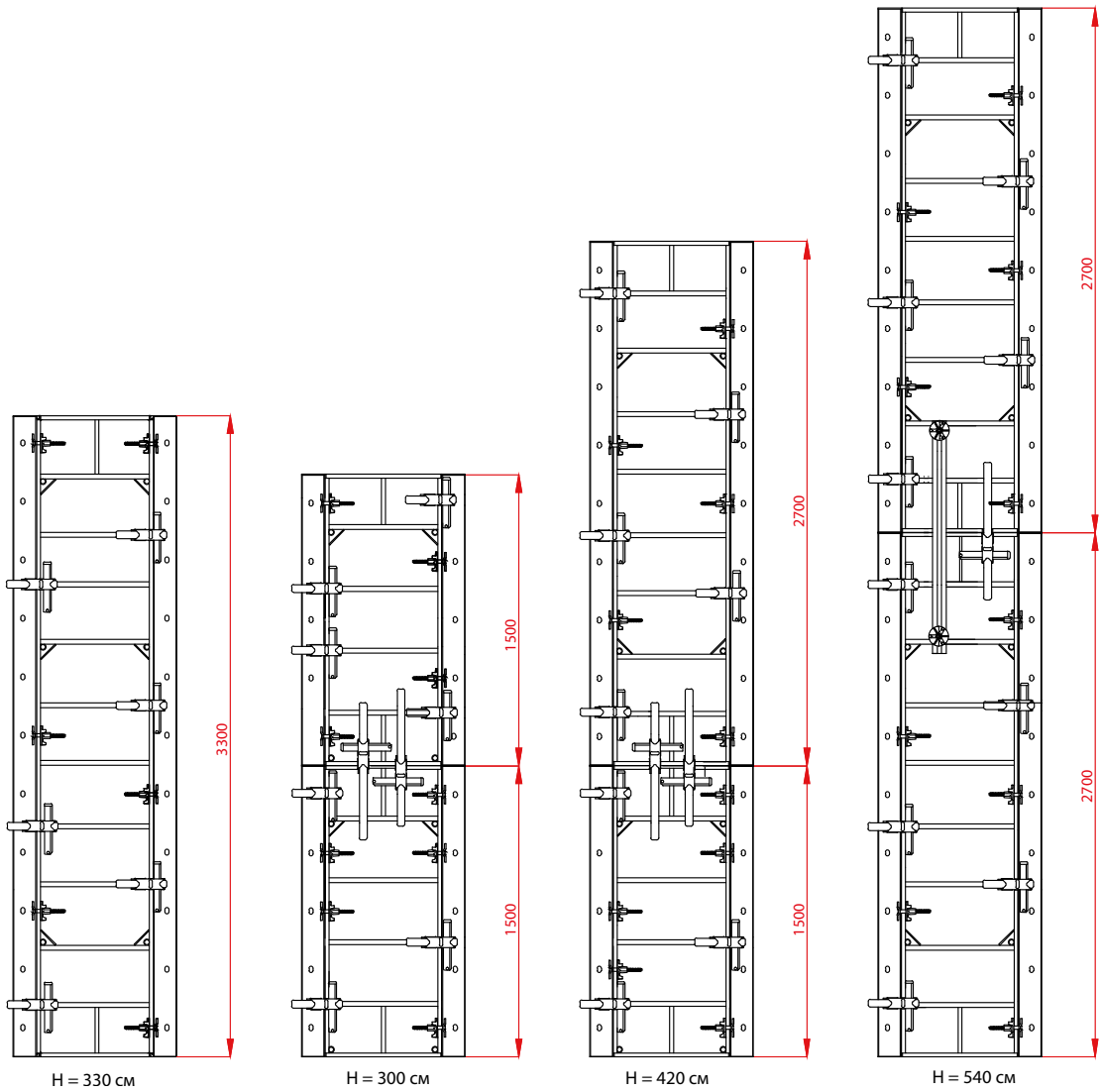
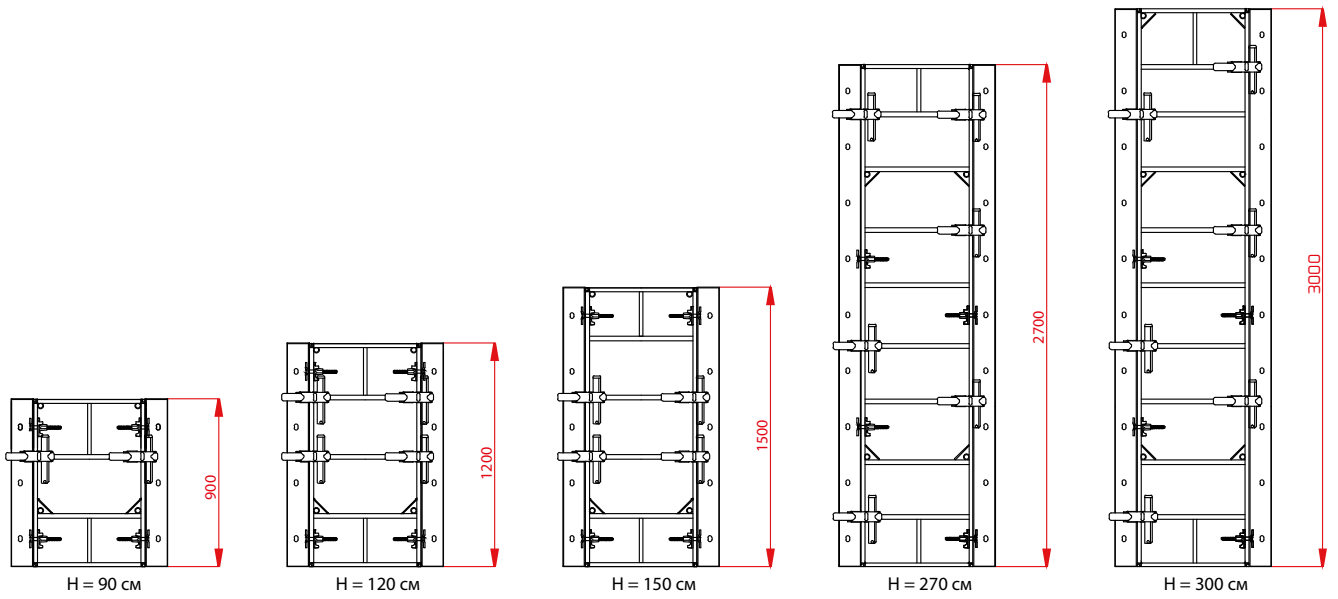

Fig. 6.2

NOTE: the Assembly instructions do not replace the EHS instructions on the construction site!
 The construction manager is responsible for the assembly of the formwork and checking if it is correctly assembled!

The tables below show the quantity of components required to form only square posts.
Rectangular posts (e.x. 25 x 60) must be individually considered.

Post 90 cm high			
Components	section from 25 x 25 to 65 x 65		
1. MIDI BOX board	4	pcs.	A0209025÷65
2. External corner	4	pcs.	A0515090
3. Connecting elements:			
Formwork lock	12	pcs.	A0901260
Centring brace	12	pcs.	A0815000
Centring nut	12	pcs.	A2532100

Post 150 cm high			
Components	section from 25 x 25 to 65 x 65		
1. MIDI BOX board	4	pcs.	A0415025÷65
2. External corner	4	pcs.	A0515150
3. Connecting elements:			
Formwork lock	16	pcs.	A0901260
Centring brace	16	pcs.	A0815000
Centring nut	16	pcs.	A2532100
4. Podpora uchylna 1,5÷3,0 m	2	pcs.	A0904001

Post 300 cm high			
Components	section from 25 x 25 to 65 x 65		
1. MIDI BOX board	4	pcs.	A0430025÷65
2. External corner	4	pcs.	A0515300
3. Connecting elements:			
Formwork lock	20	pcs.	A0901260
Centring brace	20	pcs.	A0815000
Centring nut	20	pcs.	A2532100
4. Tilting support 1,5÷3,0 m	2	pcs.	A0904002

Post 300 cm = 150 cm + 150 cm high			
Components	section from 25 x 25 to 65 x 65		
1. MIDI BOX board	8	pcs.	A0415025÷65
2. External corner	8	pcs.	A0515150
3. Connecting elements:			
Formwork lock	32	pcs.	A0901260
Centring brace	32	pcs.	A0815000
Centring nut	32	pcs.	A2532100
Formwork lock	8*	pcs.	A0901710
4. Tilting support 2,7÷6,0 m	2	pcs.	A0904002

Post 540 cm = 270 cm + 270 cm high			
Components	section from 25 x 25 to 65 x 65		
1. MIDI BOX board	8	pcs.	A0427025÷65
2. External corner	8	pcs.	A0515270
3. Connecting elements:			
Formwork lock	40	pcs.	A0901260
Centring brace	40	pcs.	A0815000
Centring nut	40	pcs.	A2532100
Formwork lock	8*	pcs.	A0901710
4. Tilting support 2,7÷6,0 m	2	pcs.	A0904002

Post 120 cm high			
Components	section from 25 x 25 to 65 x 65		
1. MIDI BOX board	4	pcs.	A0212025÷65
2. External corner	4	pcs.	A0515120
3. Connecting elements:			
Formwork lock	16	pcs.	A0901260
Centring brace	16	pcs.	A0815000
Centring nut	16	pcs.	A2532100

Post 270 cm high			
Components	section from 25 x 25 to 65 x 65		
1. MIDI BOX board	4	pcs.	A0427025÷65
2. External corner	4	pcs.	A0515270
3. Connecting elements:			
Formwork lock	20	pcs.	A0901260
Centring brace	20	pcs.	A0815000
Centring nut	20	pcs.	A2532100
4. Tilting support 1,5÷3,0 m	2	pcs.	A0904001

Post 330 cm high			
Components	section from 25 x 25 to 65 x 65		
1. MIDI BOX board	4	pcs.	A0433025÷65
2. External corner	4	pcs.	A0515330
3. Connecting elements:			
Formwork lock	24	pcs.	A0901260
Centring brace	24	pcs.	A0815000
Centring nut	24	pcs.	A2532100
4. Podpora uchylna 2,7÷6,0 m	2	pcs.	A0904002

Post 420 cm = 150 cm + 270 cm high			
Components	section from 25 x 25 to 65 x 65		
1. MIDI BOX board	4	pcs.	A0415025÷65
2. MIDI BOX board	4	pcs.	A0427025÷65
3. External corner	4	pcs.	A0515150
4. External corner	4	pcs.	A0515270
5. Connecting elements:			
Formwork lock	36	pcs.	A0901260
Centring brace	36	pcs.	A0815000
Centring nut	36	pcs.	A2532100
Formwork lock	8*	pcs.	A0901710
6. Tilting support 2,7÷6,0 m	2	pcs.	A0904002

* posts with the section of 25 x 25, 30 x 30 and 45 x 45 require 4 A091710 locks

6.2. Forming posts by using corner formwork lock and formwork boards (regular)

When SP formwork boards used as the post formwork for the 5 cm displacement module are unavailable you can use the corner formwork locks and regular formwork boards as the formwork for the posts with the sides of 20, 35, 40, 45, 50, 55, 65 or 80 cm – see figure below for installation method.

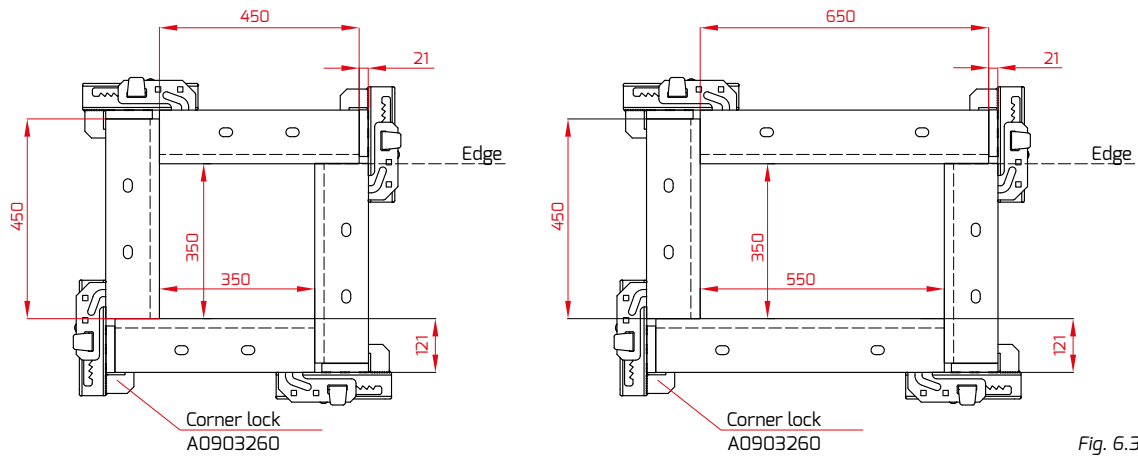

Fig. 6.3

To obtain a post with the appropriate side dimension you should use the formwork boards as shown in the table below.

Post side dimension [mm]	Formwork board dimension [mm]
150	250
200	300
300	400
350	450
400	500
450	550
500	600
550	650
650	750
800	900

The table below shows the quantity of corner locks that should be selected for a single post edge depending on its height (fig. 6.4).

Board height H [cm]	Quantity of corner locks
90	3
120	3
150	4
270	5
300	5
330	6

Posts higher than 3.3 m should be made of SP boards.

NOTE: the Assembly instructions do not replace the EHS instructions on the construction site!

The construction manager is responsible for the assembly of the formwork and checking if it is correctly assembled!

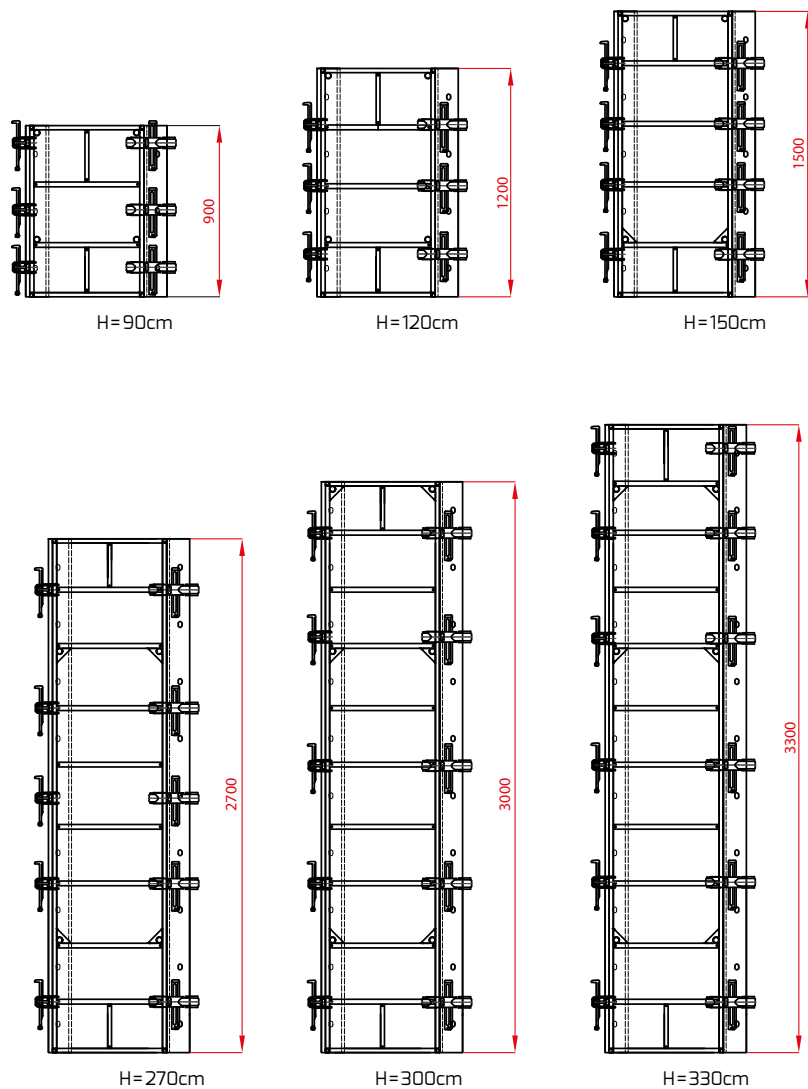

Fig. 6.4

The tables below show the quantity of components required to form a post with e.x. square section of 35 x 35 cm and 270 cm high and rectangular section of 35 x 45 cm and 330 cm high. Components required to build posts with different dimensions should be calculated in the same manner.

Post 35 x 35 x 270 cm			
1. MIDI BOX formwork board	4	pcs.	A0427045
2. Connecting elements:			
Corner formwork lock	20	pcs.	A0903260

Post 35 x 45 x 330 cm			
1. MIDI BOX formwork board	2	pcs.	A0433045
2. MIDI BOX formwork board	2	pcs.	A0433055
3. Connecting elements:			
Corner formwork lock	24	pcs.	A0903260

6.3. MIDI BOX SP board dimensions and brace system hole spacing

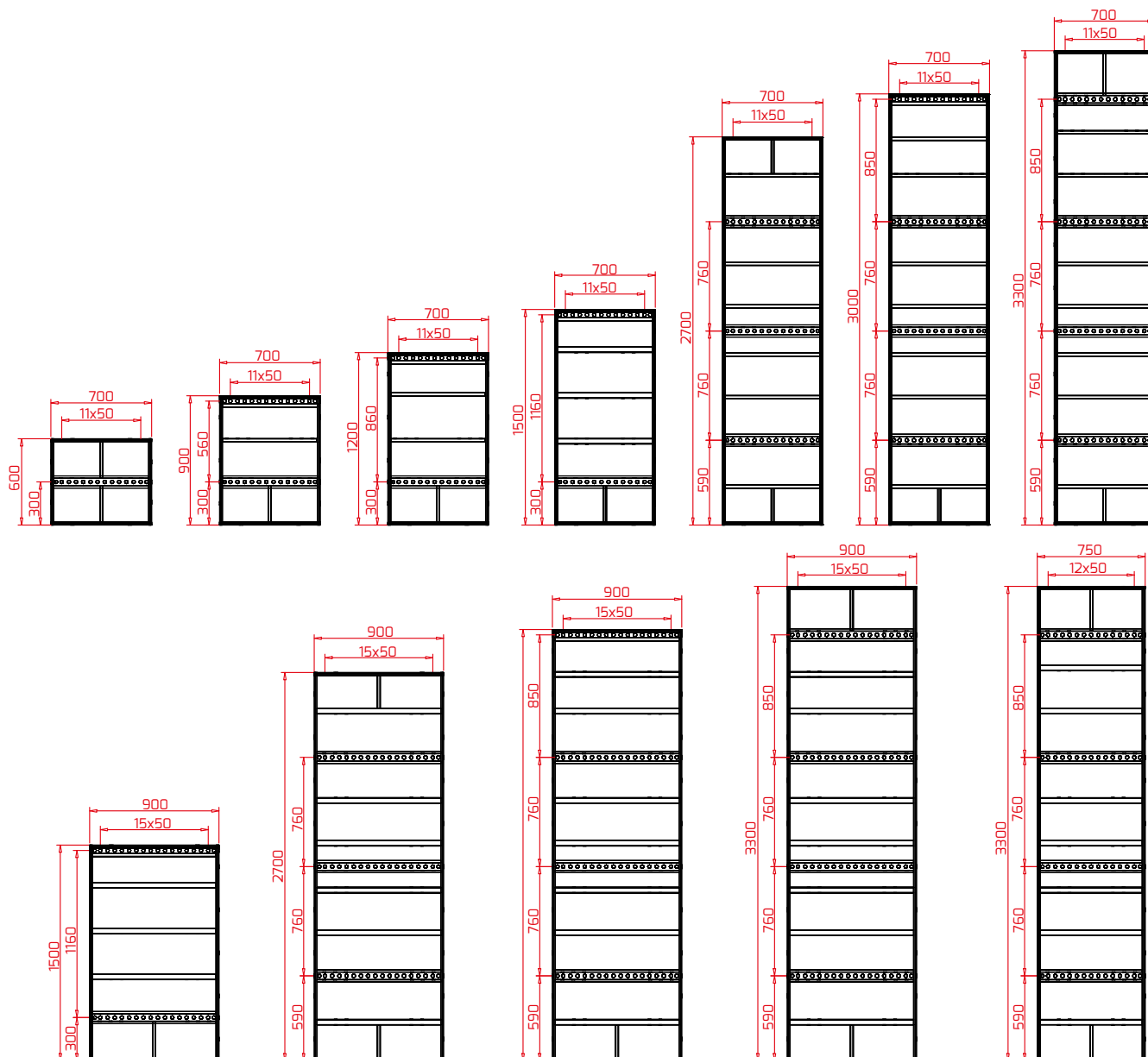

Fig. 6.5

6.4. Forming posts by using SP boards (post boards)

SP formwork boards are special boards used as a formwork for square and rectangular posts of the 5 cm displacement module. For SP70 boards the minimum and maximum post cross section is 15 x 15 cm and 55 x 55 cm, respectively. For SP90 boards the minimum and maximum cross section is 15 x 15 cm and 75 x 75 cm, respectively. The permissible concrete pressure when the posts are formed using the SP boards is 80 kN/m².

Refer to the tables next to the text that show the quantity of appropriate components included in the individual post planking based on the typical board height.

NOTE: the Assembly instructions do not replace the EHS instructions on the construction site!

The construction manager is responsible for the assembly of the formwork and checking if it is correctly assembled!

Post 90 cm high		
Components	SP 70	
1. MIDI BOX SP board	4 pcs.	A0309070
2. Connecting elements:		
SP Nut	8 pcs.	A2535000
SP Pin	8 pcs.	A2550000
Flange nut Ø100	8 pcs.	A2510100

Post 120 cm high		
Components	SP 70	
1. MIDI BOX SP board	4 pcs.	A0312070
2. Connecting elements:		
SP Nut	8 pcs.	A2535000
SP Pin	8 pcs.	A2550000
Flange nut Ø100	8 pcs.	A2510100

Post 150 cm high				
Components	SP 70		SP 90	
1. MIDI BOX SP board	4 pcs.	A0315070	4 pcs.	A0315090
2. Connecting elements:				
SP Nut	8 pcs.	A2535000	8 pcs.	A2535000
SP Pin	8 pcs.	A2550000	8 pcs.	A2550000
Flange nut Ø100	8 pcs.	A2510100	8 pcs.	A2510100
3. Tilting support 1,5+3,0 m	2 pcs.	A0904001	2 pcs.	A0904001

Post 270 cm high				
Components	SP 70		SP 90	
1. MIDI BOX SP board	4 pcs.	A0327070	4 pcs.	A0327090
2. Connecting elements:				
SP Nut	12 pcs.	A2535000	12 pcs.	A2535000
SP Pin	12 pcs.	A2550000	12 pcs.	A2550000
Flange nut Ø100	12 pcs.	A2510100	12 pcs.	A2510100
3. Tilting support 1,5+3,0 m	2 pcs.	A0904001	2 pcs.	A0904001

Post 300 cm high				
Components	SP 70		SP 90	
1. MIDI BOX SP board	4 pcs.	A0330070	4 pcs.	A0330090
2. Connecting elements:				
SP Nut	16 pcs.	A2535000	16 pcs.	A2535000
SP Pin	16 pcs.	A2550000	16 pcs.	A2550000
Flange nut Ø100	16 pcs.	A2510100	16 pcs.	A2510100
3. Tilting support 2,7+6,0 m	2 pcs.	A0904002	2 pcs.	A0904002

Post 330 cm high						
Components	SP 70		SP 75		SP 90	
1. MIDI BOX SP board	4 pcs.	A0333070	4 szt	A0333075	4 pcs.	A0333090
2. Connecting elements:						
SP Nut	16 pcs.	A2535000	16 pcs.	A2535000	16 pcs.	A2535000
SP Pin	16 pcs.	A2550000	16 pcs.	A2550000	16 pcs.	A2550000
Flange nut Ø100	16 pcs.	A2510100	16 pcs.	A2510100	16 pcs.	A2510100
3. Tilting support 2,7+6,0 m	2 pcs.	A0904002	2 pcs.	A0904002	2 pcs.	A0904002

The posts higher than the system height of the SP boards are obtained by using the so-called superstructures, i.e. by positioning at least two boards vertically.

Example: $H_s 300 = H_p 150 + H_p 150$, where:

H_s – post height

H_p – board height

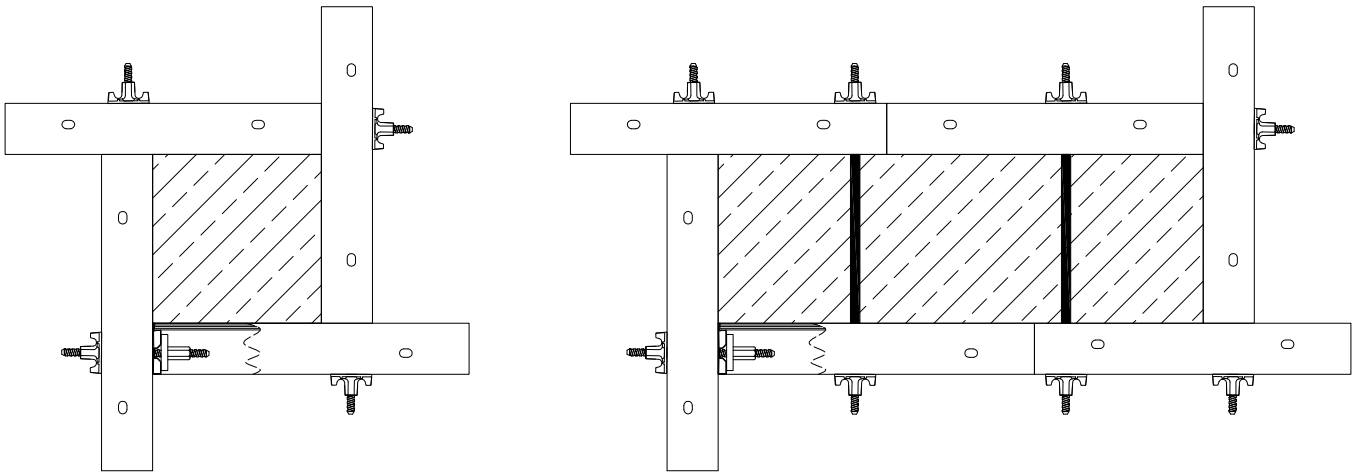

Fig. 6.6

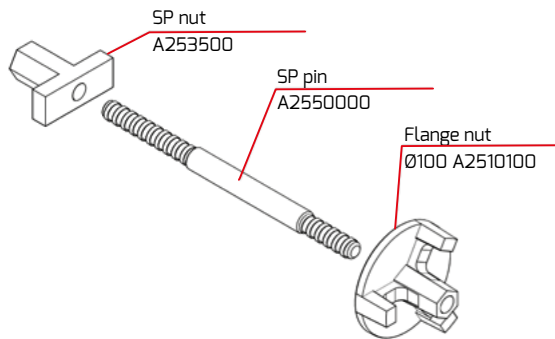

Fig. 6.7

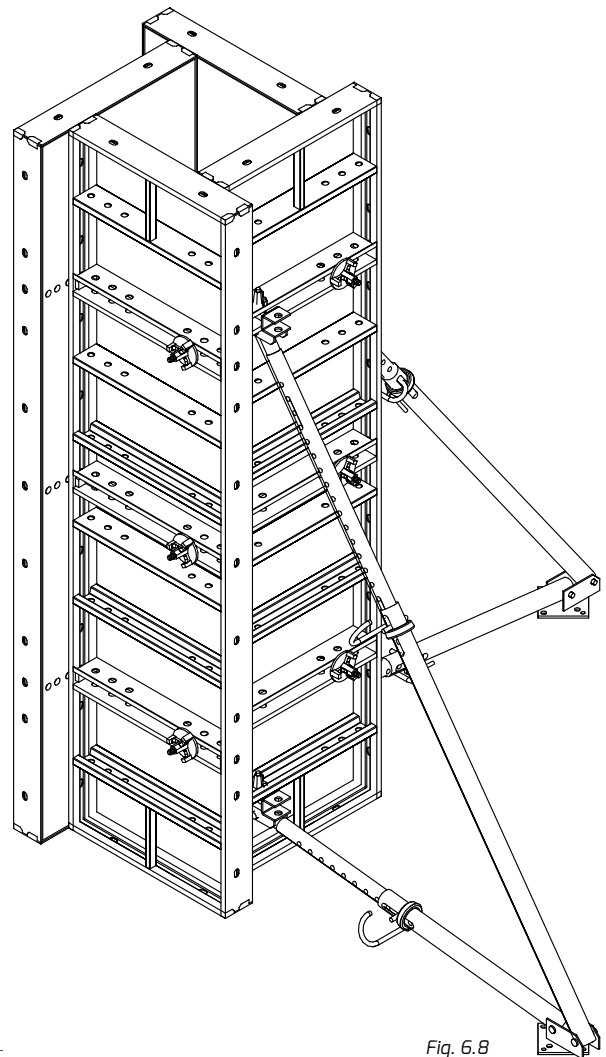

Fig. 6.8

NOTE: the Assembly instructions do not replace the EHS instructions on the construction site.

The construction manager is responsible for the assembly of the formwork and checking if it is correctly assembled!

7. LIFT SHAFT FORMWORK

7.1. Lift shaft formwork

To make the construction works more efficient it is possible to use the formwork removing elements (fig. 7.1) while concreting the lift shafts or technical shafts. They are system elements, elements of the MIDI BOX wall formwork. They are made of the steel sections and sheathing sheet protected by hot dip galvanising. If possible, the elements are installed directly in the middle of each of four walls of the internal shaft boarding. An adjustable filling insert should be installed in the external formwork segment right opposite the formwork removing element.

The structure of the formwork removing elements allows you to easily reduce the linear size by 5 cm in each of the planes of four walls. Owing to the reduction of the internal boarding dimensions it is possible to move it out freely and completely from the shaft without disassembling it and reposition it with the crane to any construction site zone. Once assembled the lift shaft formwork is used on all levels of the facility erected.

The minimum internal shaft size that we are able to erect by using the MIDI BOX system does not exceed 1,40 x 1,40 m. We use then the boards which are 30 cm wide. To compensate the plane of the internal boards in the case of this width we use the bowstring beams (A0730001). However, to do this in the larger shaft structures we use the stiffening beams (A0960001).

7.2. Lift shaft formwork assembly and disassembly

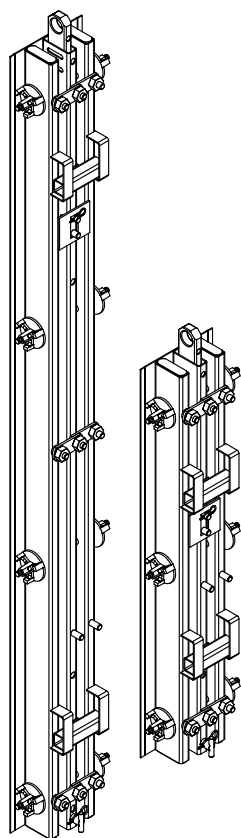

Fig. 7.1 – Formwork removing element A0640...

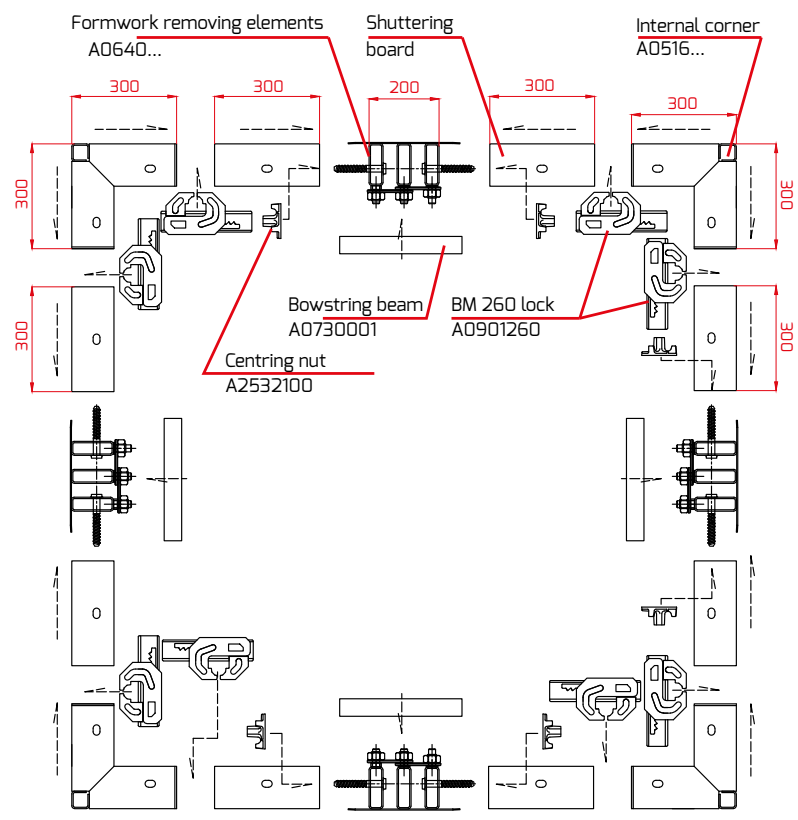

Fig. 7.2 – Diagram presenting the installation of the lift shaft formwork

The length and width of the lift shaft formwork are determined on the basis of the selected width of boards and wooden inserts. When selecting the boards you should ensure that the formwork removing element is located in the system symmetry axes. The main rule says that you should use one element per a single formwork wall (see fig. 7.2) - if possible directly in the middle of the wall. As regards the external formwork segment you should use the adjustable filling inserts no. A0636xxx (see fig. 7.3) which should be installed right opposite the formwork removing element. To make the installation it is recommended to use the boards up to 50 cm wide to make fastening directly to the formwork removing element easier.

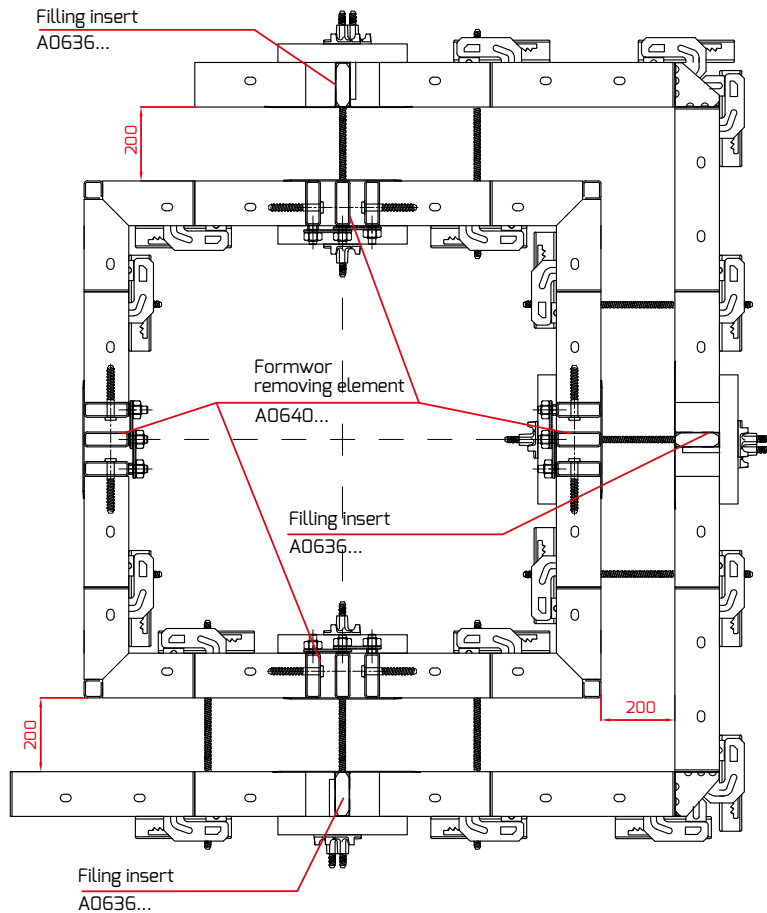

Fig. 7.3 – External set installation

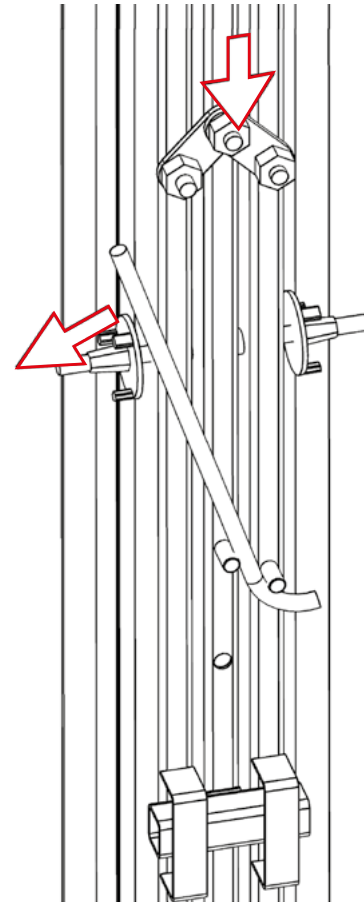

Fig. 7.4

The installation of the lift shaft starts from setting up the internal segment. It should be done in the zone intended for preparatory operations. The assembled segment is delivered to the working zone with a crane and expanded to reach the desired dimension. To expand the segment you should lower the middle part of the formwork removing element to the external part level (fig. 7.4). The next step includes the assembly of the external part of the formwork and the determination of the wall thickness (spacing between the external and internal boards). See figure 7.3.

The basic elements of the lift shaft formwork are assembled with the BM260 formwork lock. The formwork removing element is fastened to the boards with the screws welded to the main sections and nuts. The maximum diameter of the nut used for seamless connecting the element and the basic board is 100 mm. There are 6 or 8 installation points depending on the height on the formwork removing element.

The external sheathing of the formwork removing element covers the bowstring holes provided in the basic boards so that the “concrete wash” cannot leak outside the formwork. It is recommended to remove the plugs installed in the board from the formwork removing element connection side (the holes will be covered with the sheathing) so that the sheathing will adhere better to the plywood surface. The sheathing adheres tightly to the plywood due to the tightening beams which additionally straighten the formwork.

NOTE: the Assembly instructions do not replace the EHS instructions on the construction site!

The construction manager is responsible for the assembly of the formwork and checking if it is correctly assembled!

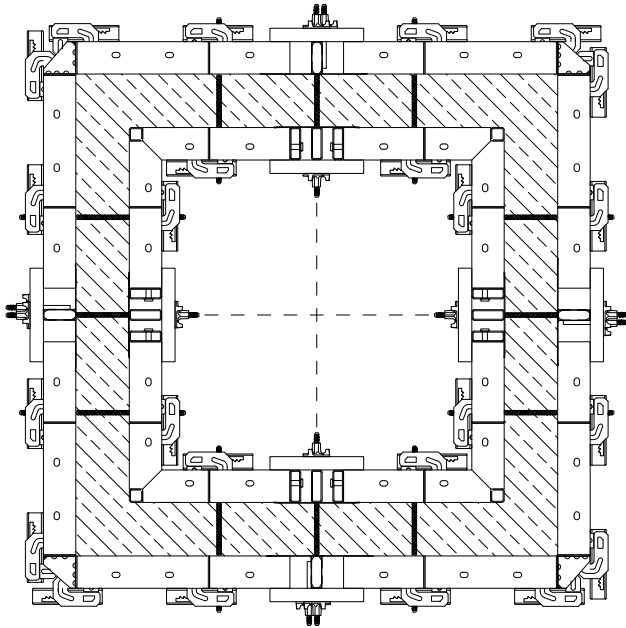

Fig. 7.5 - Formwork assembled - concrete in the formwork

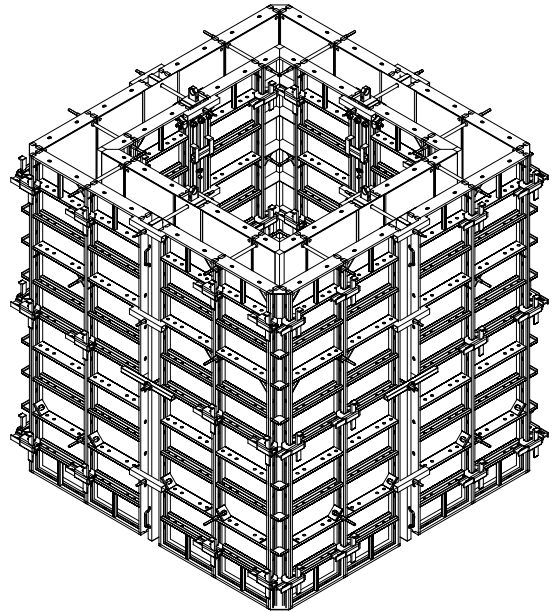

Fig. 7.6 - Sample assembled lift shaft formwork

The formwork removing element is fitted with a cap which should be installed on the transport eye (fig. 7.7) right before grouting. The cap restricts fresh concrete getting between the load-bearing profiles of the formwork removing element.

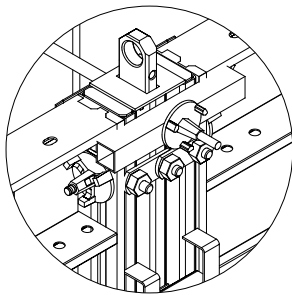

Fig. 7.7 - Cap - working position

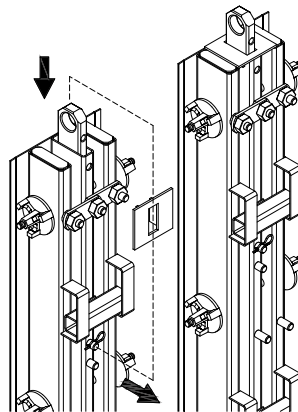

Fig. 7.8 - Cap repositioned

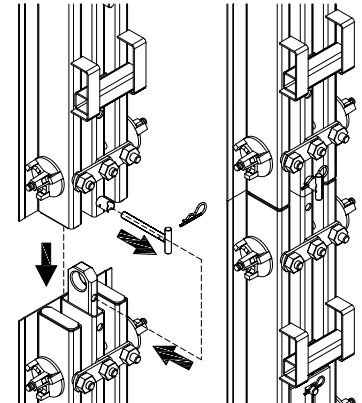

Fig. 7.9 - Joining formwork removing elements

Due to the new design the formwork removing element allows you to align two internal segments. You can align and perform system connection of the lift shaft which is e.x. 3.0 m high with the lift shaft which is e.x. 1.5 m high. The formwork removing elements are joined with the special mechanism (fig. 7.9). The formwork boards of the individual segments are joined vertically with the BM 710 locks. Instead of the BM 710 lock you can use the stiffening beam or formwork transom.

It is recommended to remove the individual lift shafts one after the other due to high forces that may occur during removal (lifting) of the joined lift shaft set (e.x. 3.0 m from 1.5 m).

Single set of the lift shaft formwork is disassembled with the crane and standard transportation slings. The formwork removing element is fitted with a transport eye where you can easily attach the slings. You should use the slings which are long enough and do not pull the internal segment to the middle. When the bowstrings, tightening beams, brackets and other elements connecting the internal segment with the wall are removed the internal segment is attached to the slings and removed vertically. Moving upwards triggers the size reducing mechanism and releases the segment so that it can be easily removed from the working zone. The clearance between the internal dimension of the shaft and the internal shaft dimension is about 5 cm and is absolutely enough to remove the segment. It is recommended that the internal segment be left on the shaft wall for up to three days.

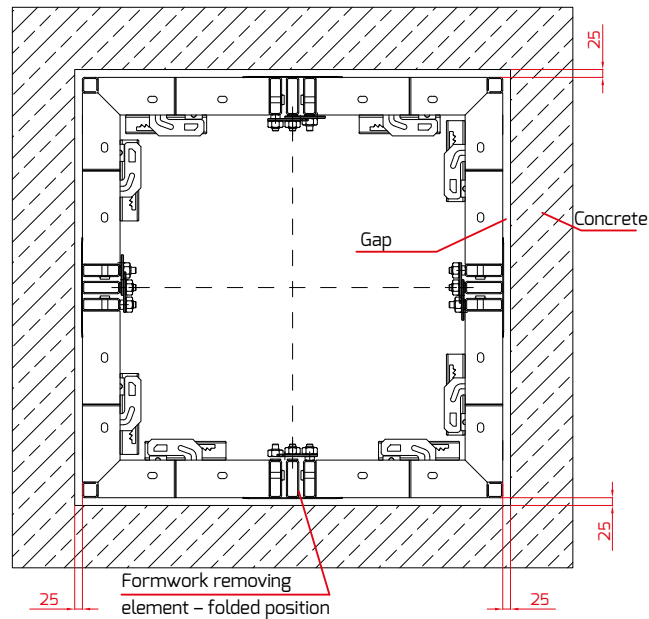

Fig. 7.10 – Folded internal set, releasing the set - dried concrete

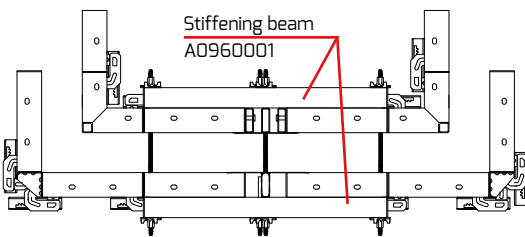

Fig. 7.11 – Sample formwork compensation with the stiffening beam

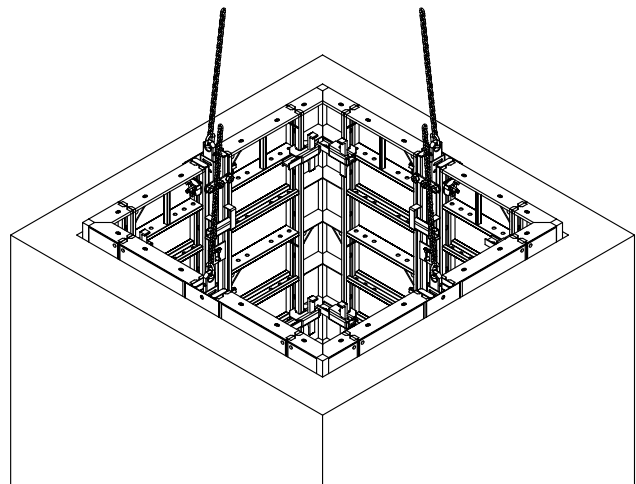

Fig. 7.12 – Internal segment disassembly

To facilitate the disassembly always coat the formwork and concrete contact surfaces with the antiadhesive liquid.

NOTE: the Assembly instructions do not replace the EHS instructions on the construction site!

The construction manager is responsible for the assembly of the formwork and checking if it is correctly assembled!

8. RADIAL WALL ERECTION

By using the radial slats you can board the multi-sided structures with a radius exceeding 2,5 m. The possibility to select the radial slats of three widths, i.e. 15, 20 and 25 cm and all MIDI BOX boards you can set-up the boarding that will reflect the part of the wall that has the shape of the arc. The radial slats are connected with the boards alternately with the locks and centring bowstrings. To connect the radial slats 2,7 m and 3,0 m high with the boarding boards you should use three BM 260 locks and three centring bowstrings (fig. 8.1). However, to connect the slat 1,5 m high you should use two BM 260 locks and two centring bowstrings. Loads are transferred from the centring bowstrings by the bowstring beams. The permissible pressure of concrete on the MIDI BOX radial boarding is 60 kN/m². The required curvature radius of the slats is obtained by tightening two nuts to the desired length.

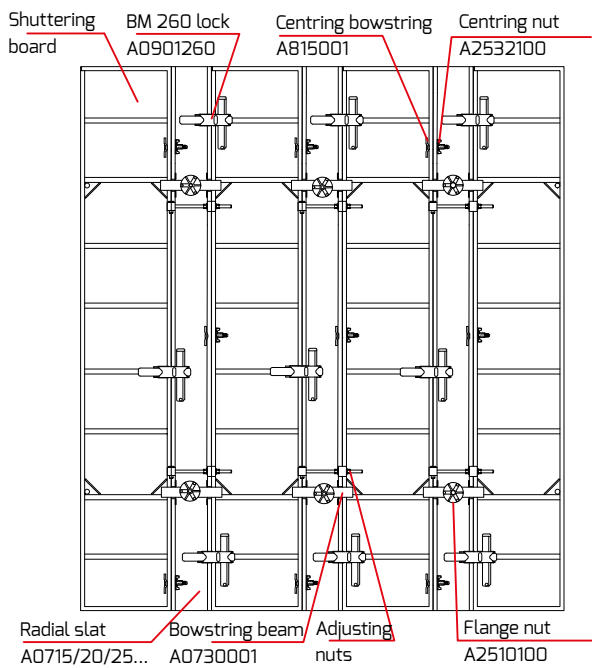

Fig. 8.1

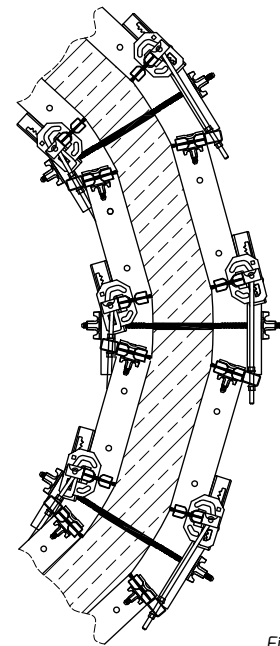

Fig. 8.2

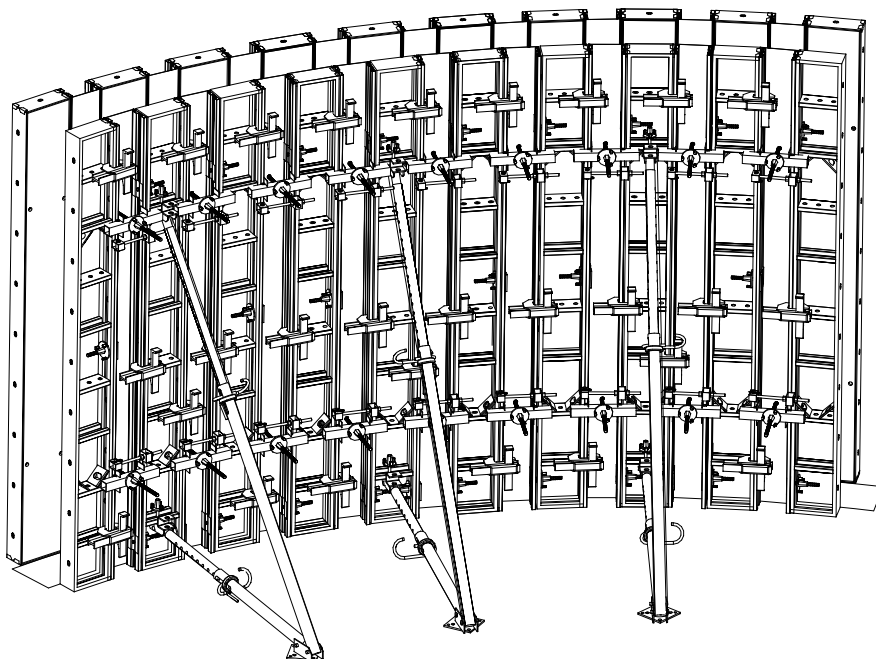

Fig. 8.3

9. PLUMBING OF WALLS AND POSTS

9.1. Walls and posts h ≤ 3,0 m high

By using the tilting prop 1,5 m high A0904001 or A0904002 (fig. 9.1) we can position the wall or post formwork ideally vertically or at the desired angle. Depending on the wall complexity or length the tilting props should be spaced every $2 \div 4,5$ m. It is enough the plumb the posts with two tilting props positioned on the adjacent post walls. The boarding structure is correctly positioned by the smooth adjustment with the "bottle screw" located in the prop arms. Adjustment range of individual arms has been shown in the AM formwork systems catalogue.

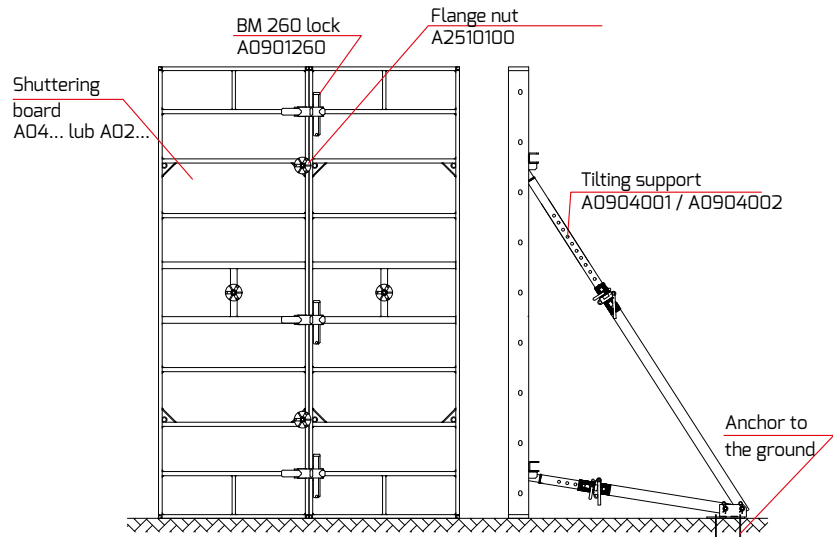

Fig. 9.1

Table presenting spacing of the shuttering board for the wall formwork

Formwork height H [m]	1.5	2.7	3	3.3	4.2	5.4	6
Maximum distance between the props [m]	4.5	3.6	3.3	3.0	2.3	1.8	1.6
A – Supporting point height [m]	1.2	2.1	2.1	2.4	2.7	3.3	4.2
Scope of support application	A0904001			A0904002			

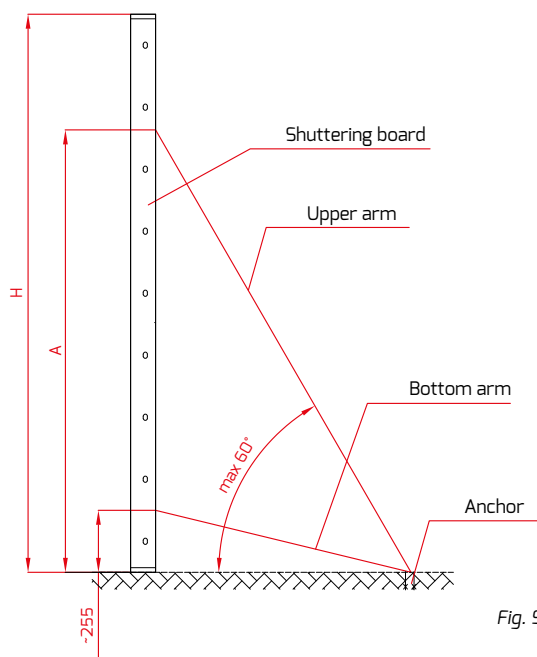

Fig. 9.2

The recommended safe support spacing should not exceed 3 m due to the limitations of the ground support anchoring method.

NOTE: the Assembly instructions do not replace the EHS instructions on the construction site!

The construction manager is responsible for the assembly of the formwork and checking if it is correctly assembled!

9.2. Walls and posts $h > 3,0$ m high

High walls can be plumbed and stabilised with the long raking shores (A0904005) i.e. the props that can be adjusted within $l = 4,75 \text{ m} \div 5,55 \text{ m}$ and the tilting props (A0904002) (fig. 9.1). The other wall plumbing method includes using the ceiling props along with the prop feet (A0904012) and the prop couplings (A0904011).

Two ceiling prop of any but required length are connected with each other by using the connecting sheets and four screws $\varnothing 12 \times 40 \text{ mm}$. These connected props are completed with:

- a) prop foot at the bottom
- b) prop coupling at the top

to connect the prop with the ribbed structure of the boarding boards.

The threaded parts of both props are fitted above the G-hook with the split locknuts to lock the props at the required height. Select the locknut according to the diameter of the used ceiling support threaded pipe.

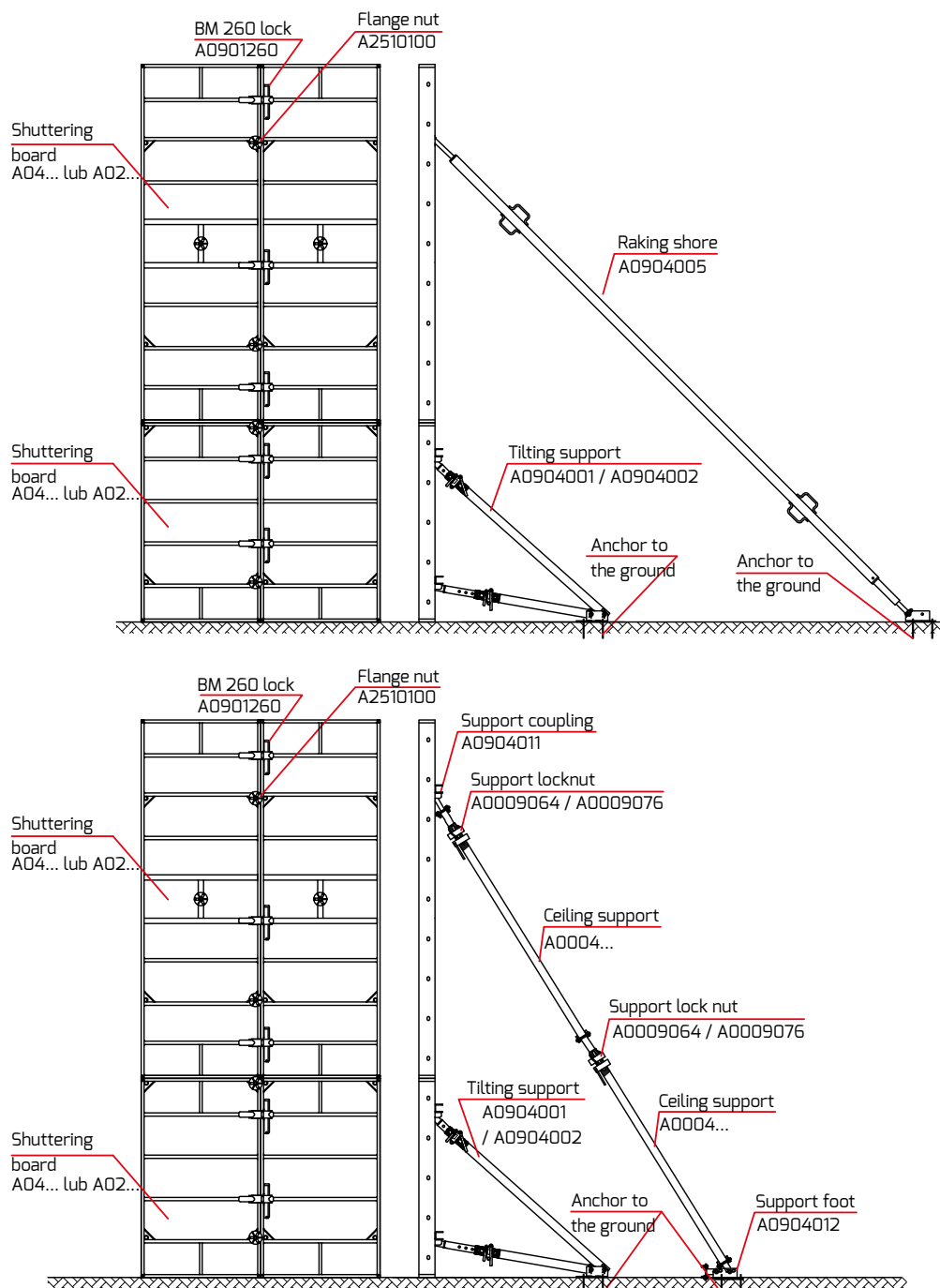

Fig. 9.3

10. ONE-SIDED FORMWORK

The trestle brackets are used for erecting the one-sided formwork. The one-sided formwork is used when connecting the vertical walls located at the existing buildings, slopes etc. By using the brackets it is possible to erect the walls up to 4,5 m high. The forces generated by the concrete pressure are transferred both by the anchors concreted at 45° in the ground boards and the ground board alone. The existing building wall must withstand the hydrostatic pressure of the fresh concrete. However, the foundations or bottom board or the ceilings are responsible for transferring the forces generated by the trestle brackets. The anchoring method is selected depending on the tensile forces present in the anchors which depend on the brackets spacing, concreted wall height and concreting speed (concrete pressure). The trestle prop should be connected with each other by using the standard pipes to ensure better stiffness.

The components of one-sided formwork are described in the formwork systems catalogue.

The trestles spacing should be adapted individually to each case while considering the following factors:

- concreting height (load from the concrete pressure),
- anchoring element selection,
- selection of the elements ensure the connection of the board with the trestle bracket,
- shuttering board laying method,
- board geometry (board crosspieces spacing).

The anchoring rods should be concreted when building the bottom board or ceiling. It is recommended to weld the anchors to the reinforcement. The rod should be connected with the bowstring by using the anchor coupling.

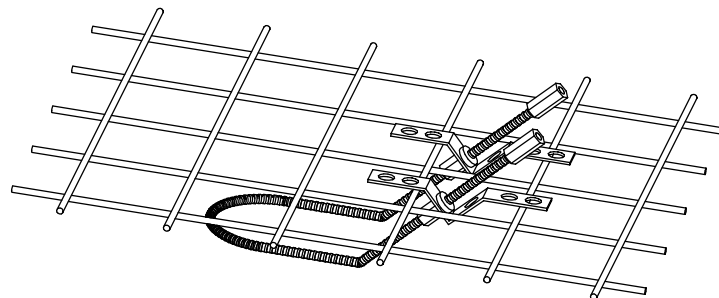

Fig. 10.1

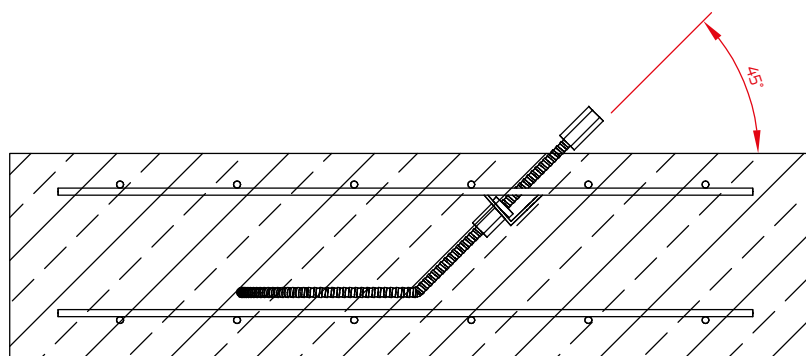

Fig. 10.2

When the concrete cures in short time you should use the anchoring elements which are screwed on the concreted anchoring rod end. The feet should be propped from the bottom i.e. on the lower level by using the props located in the line in which the adjustable props are positioned.

NOTE: the Assembly instructions do not replace the EHS instructions on the construction site!

The construction manager is responsible for the assembly of the formwork and checking if it is correctly assembled!

The anchoring method is selected depending on the tensile forces present in the anchors which depend on the brackets spacing, concreted wall height and concreting speed (concrete pressure). You can use waved anchors (fig. 10.4), hook or loop anchors (fig.10.3).

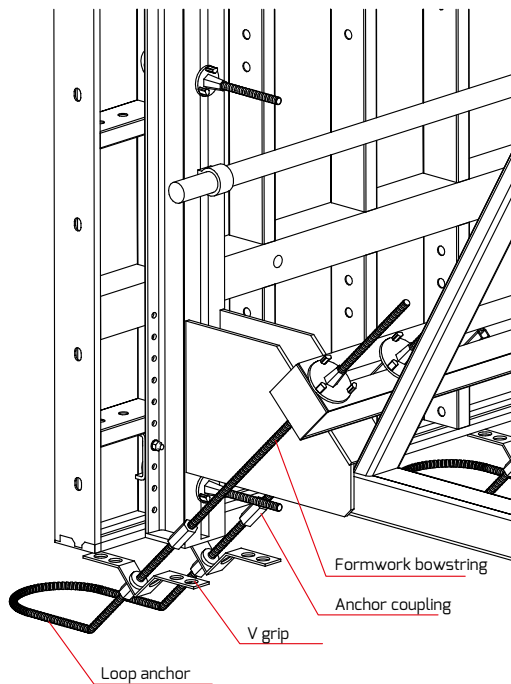

Fig. 10.3

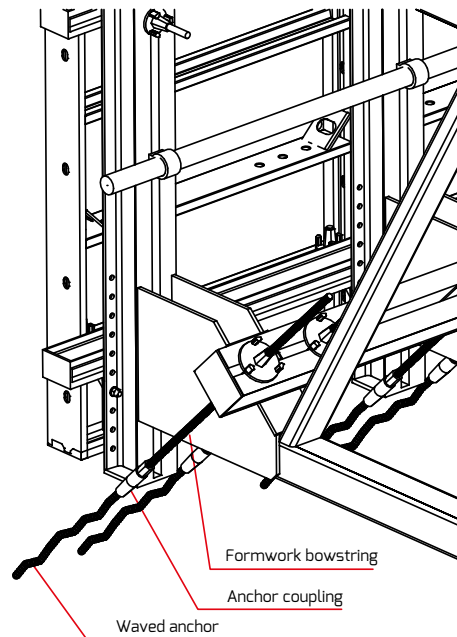

Fig. 10.4

The permissible load of the D15 anchoring loop with the Dywidag thread is 2×90 kN. The rods spacing in the single anchoring loop is 230 mm. It is recommended to use the same rods spacing both in the case of the waved and the hook anchors.

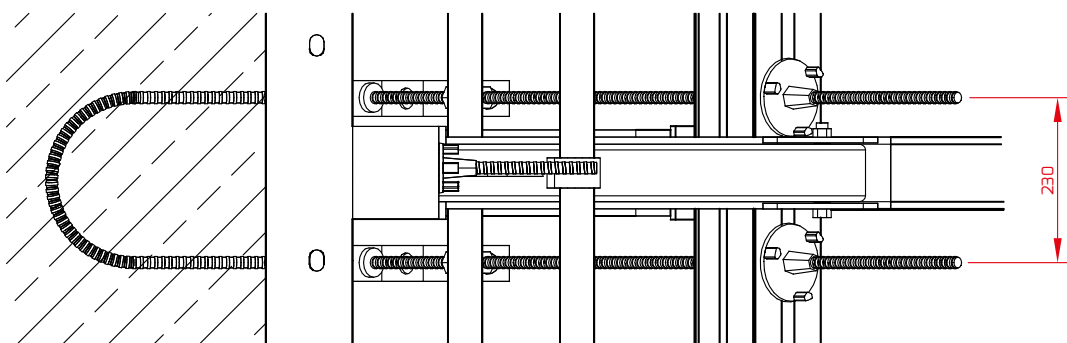

Fig. 10.5

The basic difference in the one-sided formwork is connected with the shuttering boards positioned vertically or horizontally.

10.1. One-sided formwork with the horizontally positioned boards

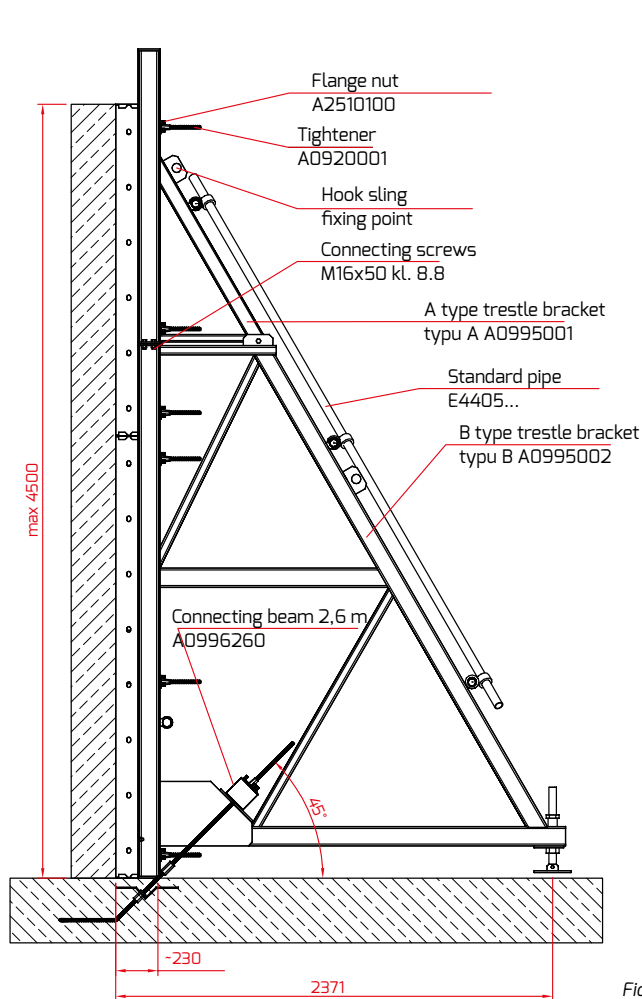

Fig. 10.6

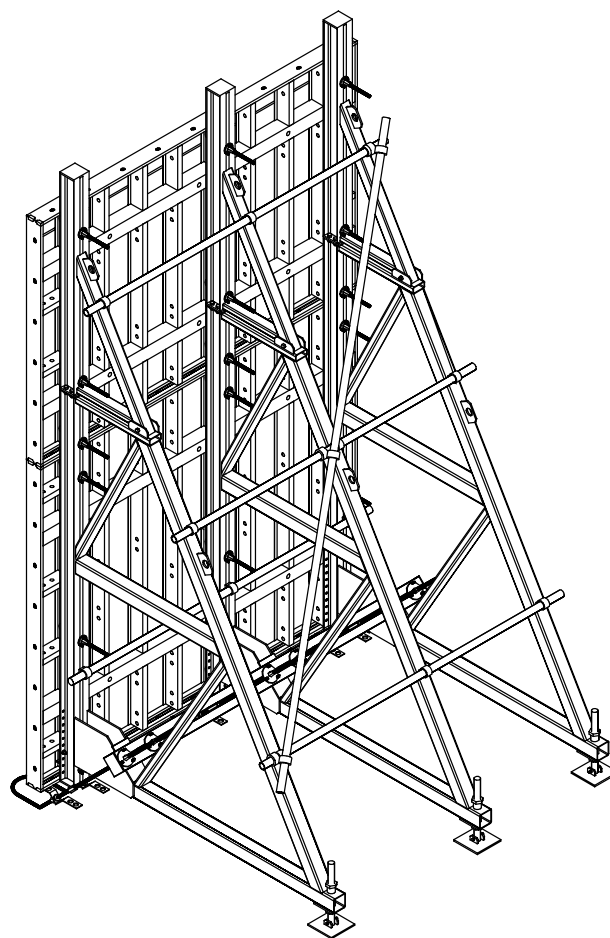

Fig. 10.7

The shuttering boards should be installed with the tighteners A092001 (it presses the board to the trestle bracket) and with the angle bracket A0997001 (it prevents the boards from moving under their own weight).

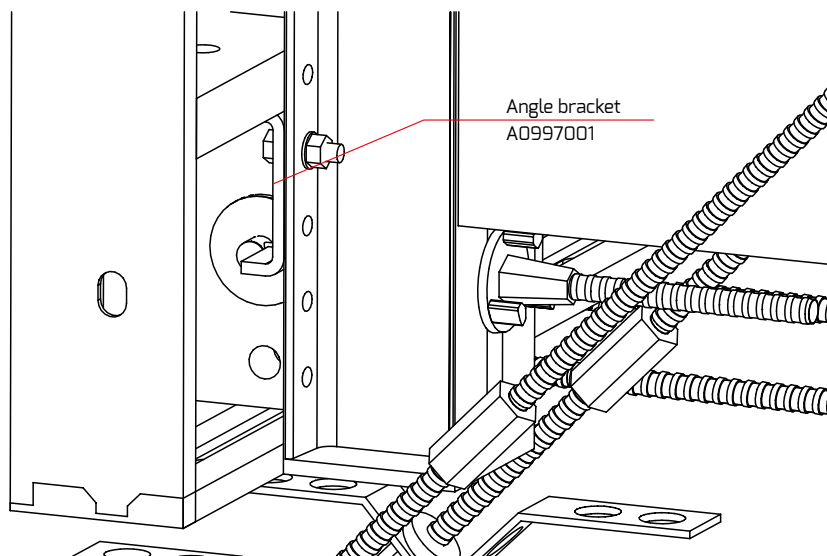

Fig. 10.8

NOTE: the Assembly instructions do not replace the EHS instructions on the construction site!

The construction manager is responsible for the assembly of the formwork and checking if it is correctly assembled!

10.2. One-sided formwork with the vertically positioned boards

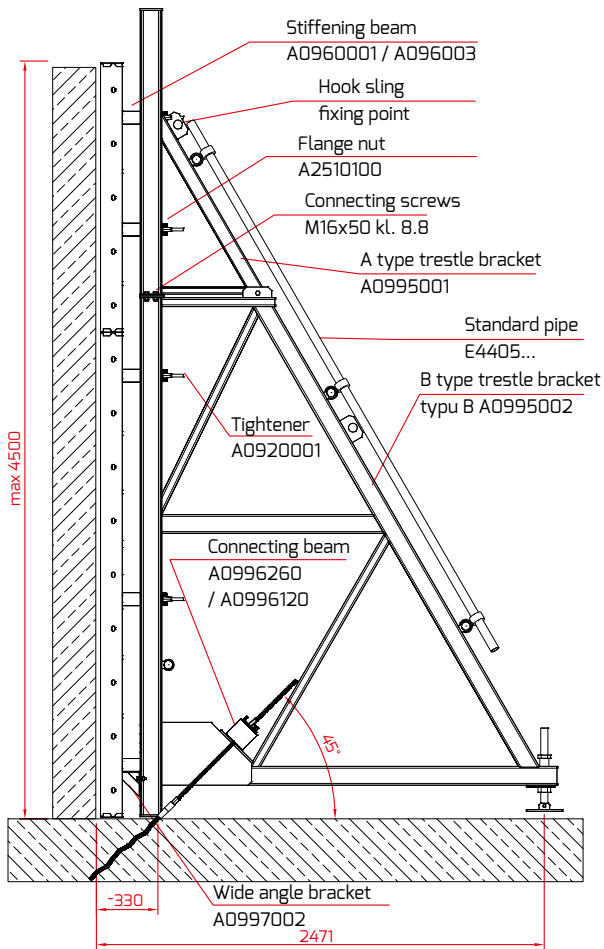

Fig. 10.9

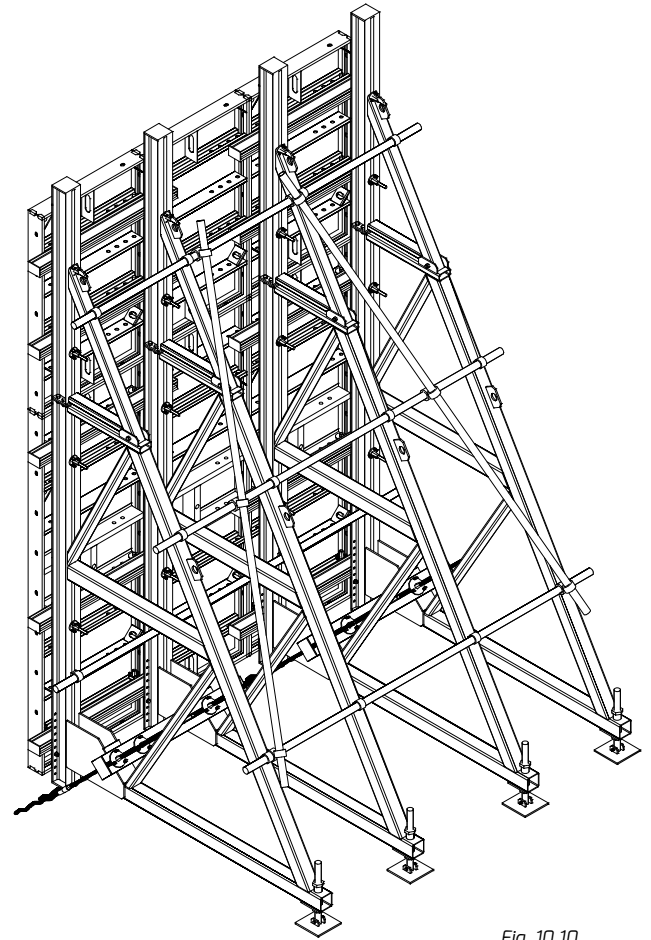

Fig. 10.10

The shuttering boards should be installed with the tighteners A092001, stiffening beams A0960... (it presses the board to the trestle bracket) and with the wide angle bracket A0997002 (it prevents the boards from moving under their own weight).

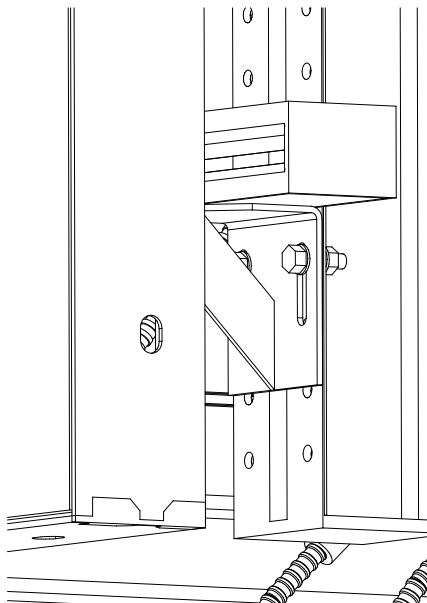

Fig. 10.11

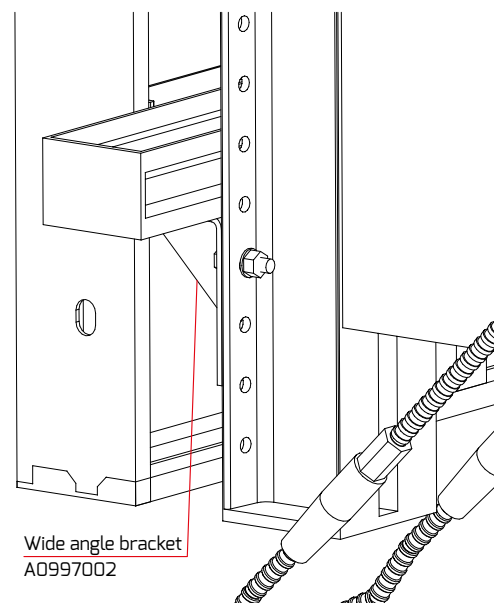

Fig. 10.12

11. DETERMINING THE MAXIMUM CONCRETING SPEED IN A PRACTICAL MANNER

It is recommended to practically use the CIRIA method. It results from the following premises:

- this method considers the greater number of the factors that affect the maximum pressure,
- it gives the results that are closer to the experimental data,
- it gives the more secure results.

This method was adapted to the load capacity of the MIDI BOX formwork produced by ALTRAD-MOSTOSTAL by preparing six nomograms used for determining the maximum concreting speed with the formwork load capacity of 60 kN/m² and 80 kN/m². These nomograms specify the dependence between the height of the concreted element and the maximum concreting speed with various concreting temperatures

Fig. 11.1 concerns the wall concreting speed (when using the shuttering boards of the load capacity of 60 kN/m² and the concrete with the setting delaying admixtures.

Fig. 11.2 concerns the post concreting speed (when using the shuttering boards of the load capacity of 60 kN/m² and the concrete with the setting delaying admixtures.

Fig. 11.3 concerns the wall concreting speed (when using the shuttering boards of the load capacity of 80 kN/m² and the concrete with the setting delaying admixtures.

Fig. 11.4 concerns the post concreting speed (when using the shuttering boards of the load capacity of 80 kN/m² and the concrete with the setting delaying admixtures.

Fig. 11.5 concerns the post concreting speed (when using the shuttering boards of the load capacity of 60 kN/m² and the concrete without the setting delaying admixtures.

Fig. 11.6 concerns the wall concreting speed (when using the shuttering boards of the load capacity of 60 kN/m² and the concrete without the setting delaying admixtures.

Note:

Light MIDI BOX boards with part no. A02... – boards with load-bearing capacity of 60 kN/m²

Heavy MIDI BOX boards with part no. A04... – boards with load-bearing capacity of 80 kN/m²

To determine the maximum concreting speed find the concreted element height on the horizontal axis and draw a vertical line from this point to the point where it crosses the diagram of the given concreting temperature. Draw a horizontal straight line from the crossing point and the point where it crosses the vertical axis is the maximum concreting height.

When using the nomograms you should follow the following remarks:

1. The maximum height of the concrete mixture layer laid at one time cannot exceed 2 m.
2. The concreting speed read from the nomograms is understood as the mean speed obtained at the entire concreted wall height so it is calculated as the relationship: $v = H/t$, where H is the height of the concreted wall and t – the time to fill the formwork up to the H height.
3. The nomograms were prepared for the mixture of the temperature of 5, 6, 8, 10, 15, 20, 25 and 30°C. If the mixture temperature is included with the temperatures above the results should be interpolated for two curves which represent the real situation in the closest manner.
4. If the curve approaches the horizontal axis which means the zero laying speed concreting should be divided into two stages (according to item 1 the thickness of the layer that constitutes one stage cannot be greater than 2,0 m) and before the second stage you should wait until setting of the concrete mixture is completed (from a few until several hours depending on the cement setting time and the temperature of the mixture laid at stage one.

NOTE: the Assembly instructions do not replace the EHS instructions on the construction site!

The construction manager is responsible for the assembly of the formwork and checking if it is correctly assembled!

Boarding of walls according to CIRIA for $P_{max} = 60$ kPA concrete with the setting delaying admixtures

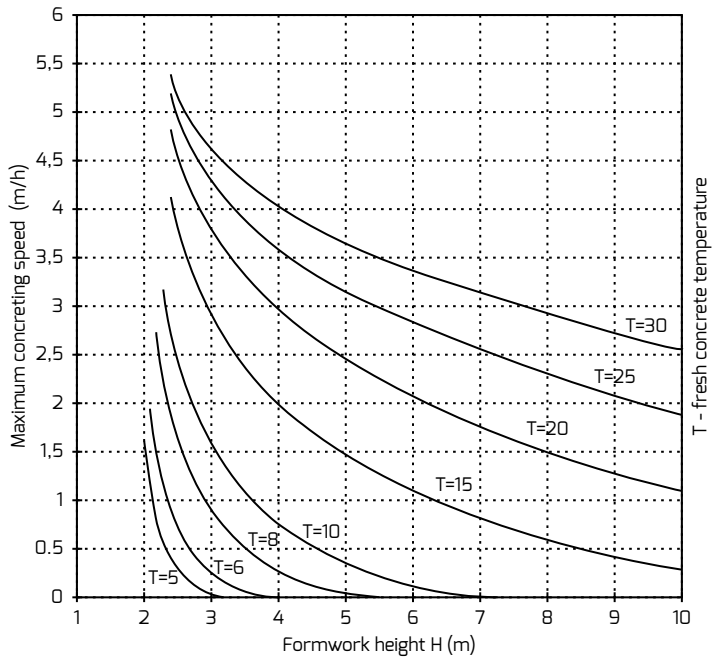

Fig. 11.1

Boarding of posts according to CIRIA for $P_{max} = 60$ kPA concrete with the setting delaying admixtures

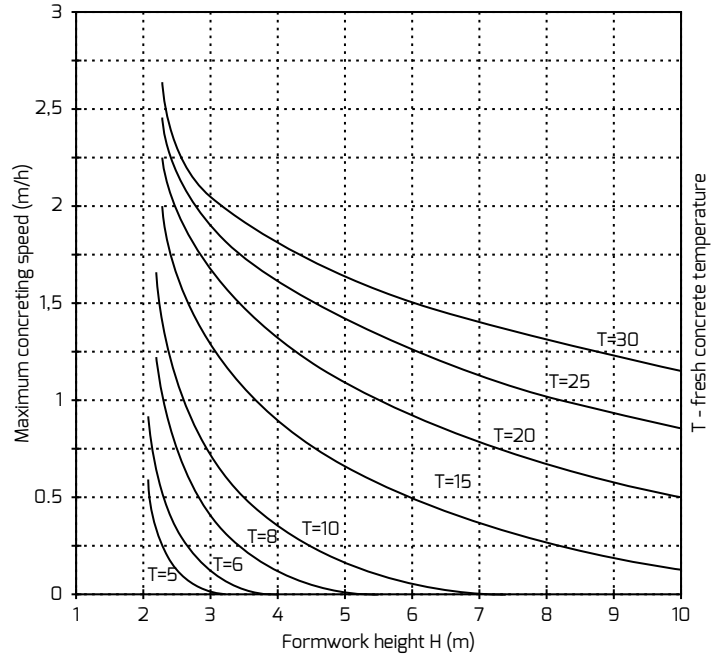

Fig. 11.2

Boarding of walls according to CIRIA for $P_{max} = 80$ kPA concrete without the setting delaying admixtures

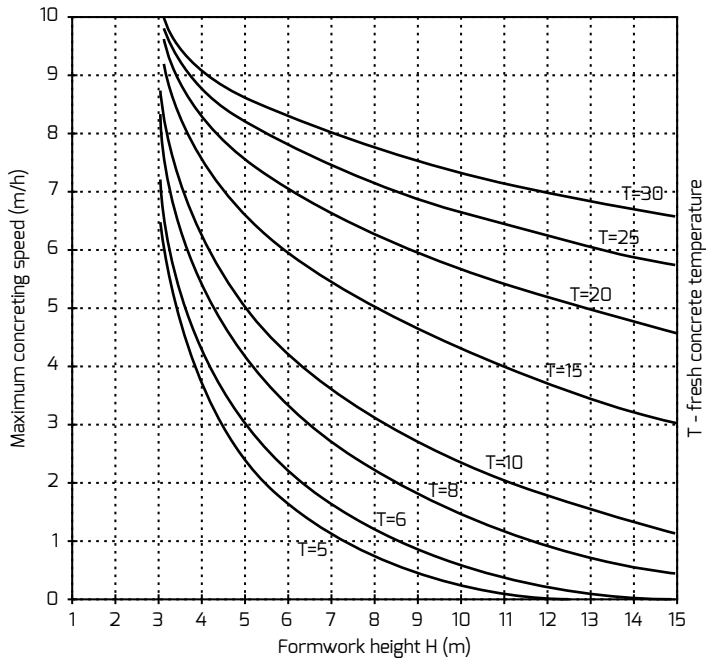

Fig. 11.3

Boarding of posts according to CIRIA for $P_{max} = 80$ kPA concrete with the setting delaying admixtures

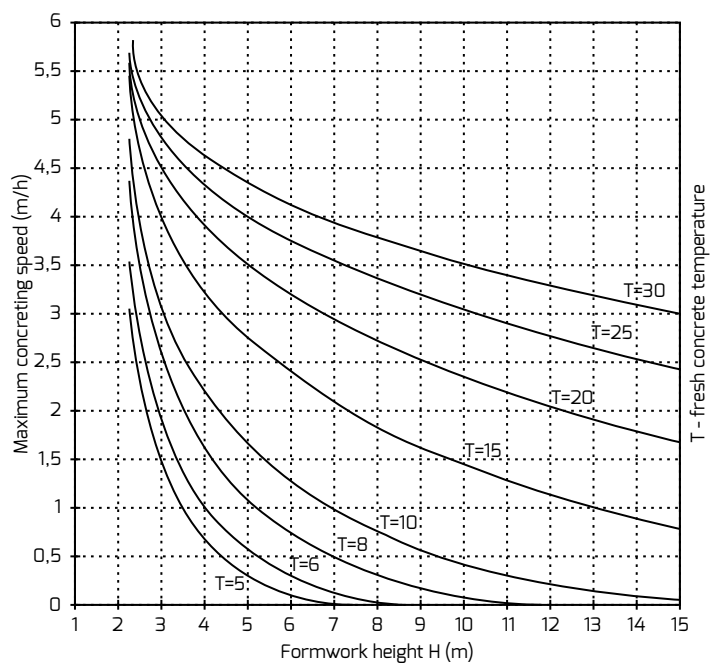

Fig. 11.4

Boarding of posts according to CIRIA for Pmax = 60 kPa concrete with the setting delaying admixtures

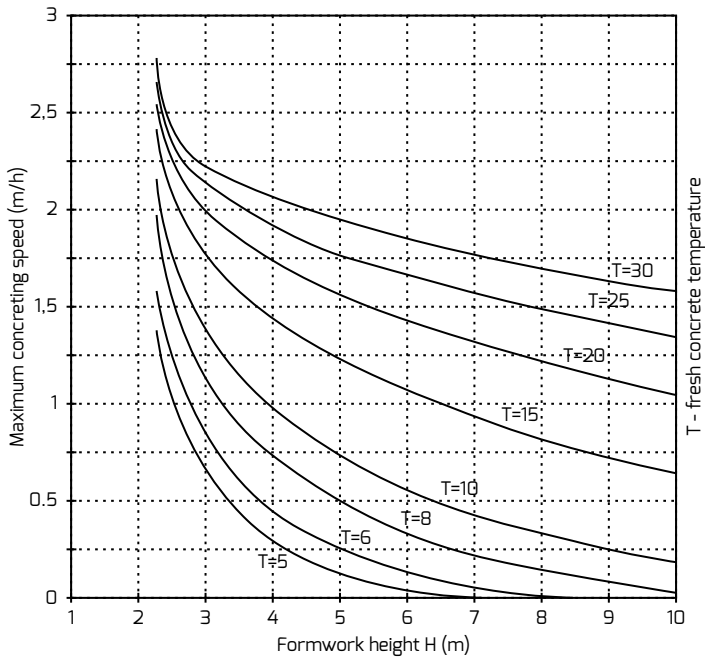

Fig. 11.5

Boarding of walls according to CIRIA for Pmax = 60 kPa concrete with the setting delaying admixtures

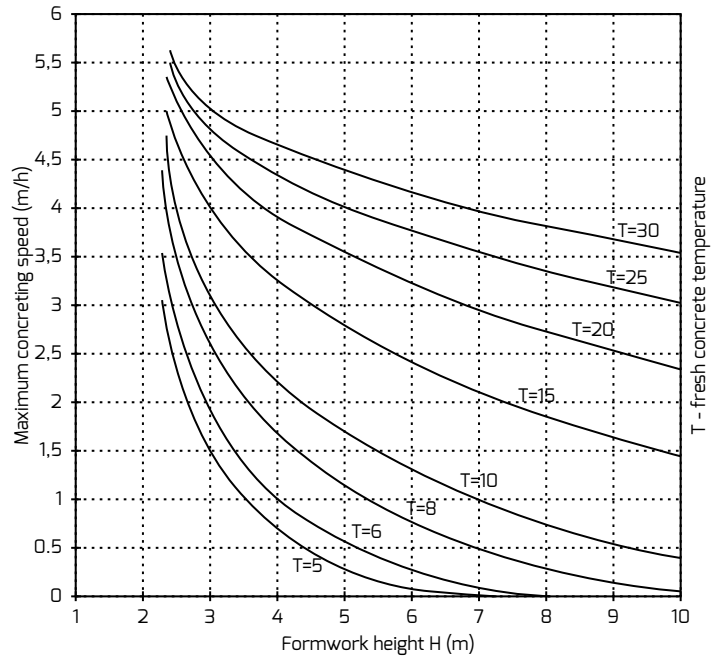

Fig. 11.6

Below are two examples presenting the usage of the nomograms:

- As regards the post 4 m high which is concreted at the temperature of 10°C without the setting delaying admixtures in fig. 9,5 you can see that the maximum concreting speed is approx. 1 m/h. To obtain the mean speed at the entire formwork height you should lay the concrete layers 1 m thick every hour or lay the concrete layers 50 cm thick every 0,5 hour. In extreme cases this layer can be 2,0 m thick but concreting should be continued after 2 hours.

The total post concreting time should be:

$$t = 4 \text{ m} : (1 \text{ m/h}) = 4 \text{ h}$$

$$t = \frac{4 \text{ m}}{1 \text{ m/h}} = 4 \text{ h}$$

- As regards the wall 5,5 m high which is concreted at the temperature of 10°C without the setting delaying admixtures in fig. 9.6 you can see that the maximum concreting speed is approx. 1,5 m/h. To obtain the mean speed at the entire formwork height you should lay the concrete layers 1,5 m thick every hour or lay the concrete layers 75 cm thick every 0,5 hour or the layers 50 cm thick every 20 minutes. In extreme cases this layer can be 2,0 m thick but concreting should be continued after 1 hour and 20 minutes.

The total post concreting time should be:

$$t = 5,5 \text{ m} : (1,5 \text{ m/h}) = 3,67 \text{ h} = 3 \text{ h } 40 \text{ mins}$$

$$t = \frac{5,5 \text{ m}}{1,5 \text{ m/h}} = 3,67 \text{ h} = 3 \text{ h } 40 \text{ mins}$$

NOTE: the Assembly instructions do not replace the EHS instructions on the construction site!

The construction manager is responsible for the assembly of the formwork and checking if it is correctly assembled!

12. GIRDER AND PLYWOOD CEILING FORMWORK

The conventional ceiling formwork system (popularly called the girder and plywood formwork) is used for boarding of the ceilings of any shape. Due to the small number of elements that constitute this system its assembly and disassembly is fast and easy. The ceiling formwork system allows also to make the binders of various sections.

The conventional girder and plywood formwork of ALTRAD-MOSTOSTAL consists of three basic structural element groups:

- ceiling props,
- wooden girders,
- formwork sheathing - or plywood with the appropriate technical parameters and the supplementary elements used for positioning the formwork i.e.
- heads that prop the girders on the props,
- tripods used for vertical prop positioning,
- couplings and pipes required to stiffen and stabilise the props,
- railing posts to install the railings in the form of (planks),
- girder clamps (brackets),
- flange brackets.

12.1. Guidelines concerning the assembly of the girder and plywood ceiling

12.1.1. Preparations

Professional preparation of the tasks connected with the assembly in terms of their organisation has a substantial impact on the speed of the assembly works completion. Dividing the undertaking completed in the correct stages and selecting the optimal props and girders spacing avoid the outages on the construction site and increase the dynamics of the works completed.



Before the assembly works the employees should be trained in terms of the peculiarities of the assembly and disassembly of ceiling formwork.

12.1.2. Assembly of the girder and plywood formwork.

Before the assembly collect the elements in the place where the formwork will be assembled.

1. Install the cross heads on the props.

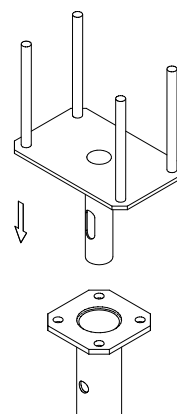

Fig. 12.1

2. Expand the props to obtain the required height and lock the props. Pre-adjust the prop height by using the G-hook and the L-hook (nut).

G-hook is used for preventing the prop from lowering
L-hook adjusted the “precise” prop expansion.

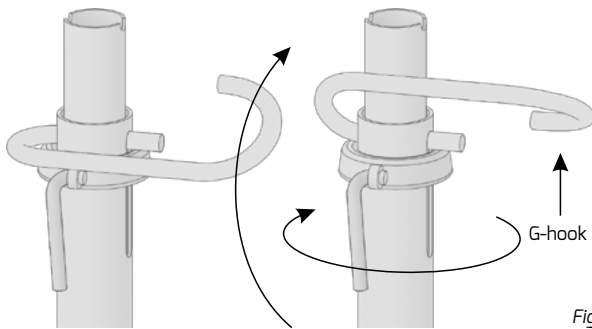

Fig. 12.2

3. Position the tripods (at least 4 pieces in the room corners). Space the tripods according to the data contained in the props spacing tables or according to the technical design.

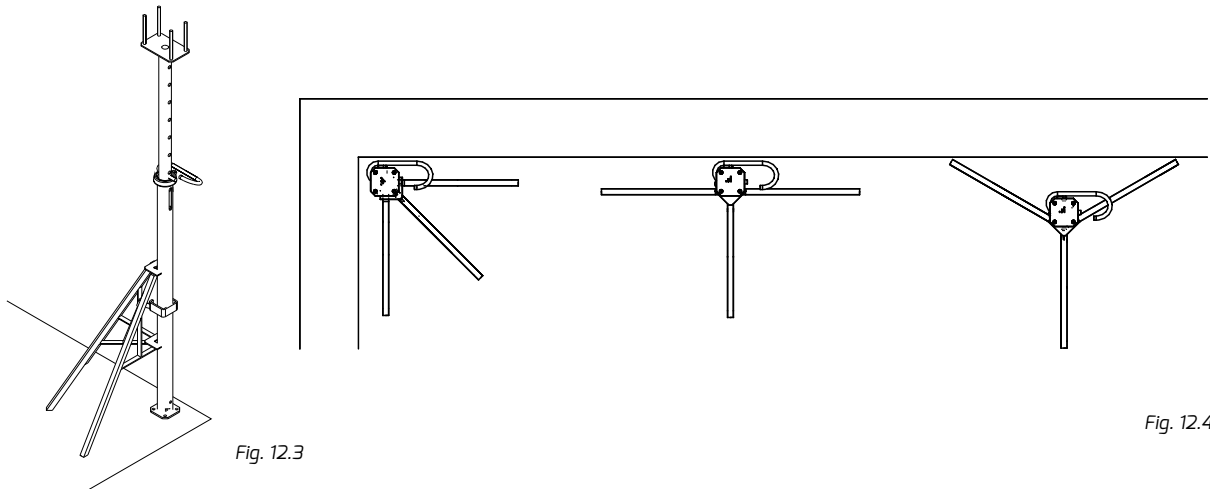

Fig. 12.3

Fig. 12.4

4. Lay the longitudinal girders on the prop heads. The girder should protrude at least 6 cm beyond the prop vertical axis. Where the girders overlay in terms of length the heads should be rotated 90° so that two girders are positioned in parallel next to each other to form one head. The overlay length should not be less than the head sheet dimension.

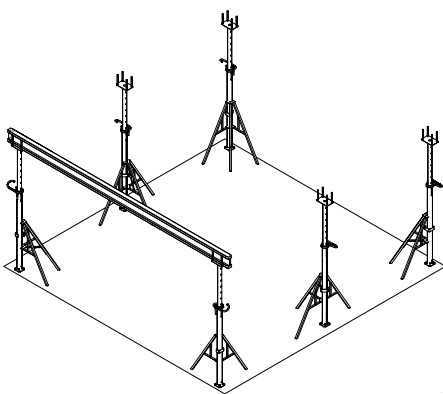

Fig. 12.5

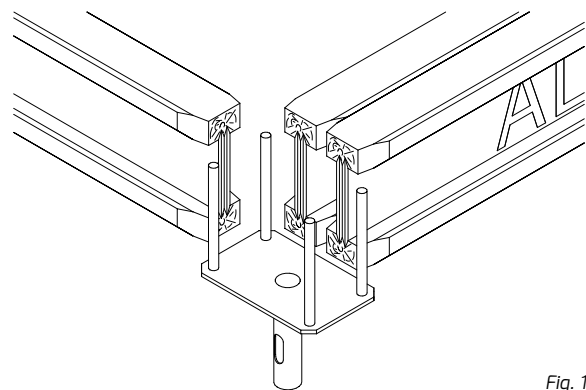

Fig. 12.6

NOTE: the Assembly instructions do not replace the EHS instructions on the construction site!

The construction manager is responsible for the assembly of the formwork and checking if it is correctly assembled!

5. Set the formwork level with the nut (L-hook) on the prop.

6. Space the heads with the intermediate heads according to the guidelines contained in the props spacing table.

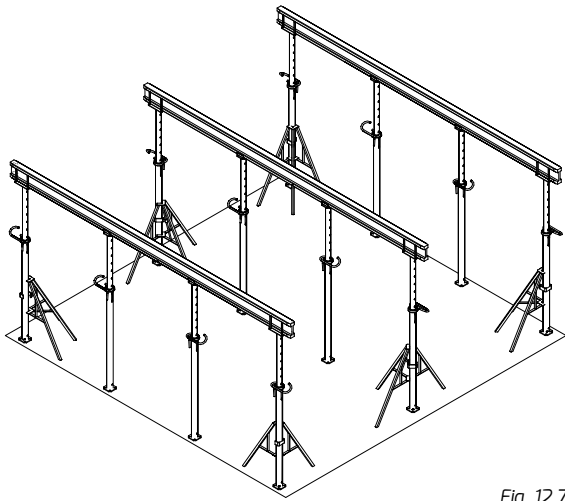

Fig. 12.7

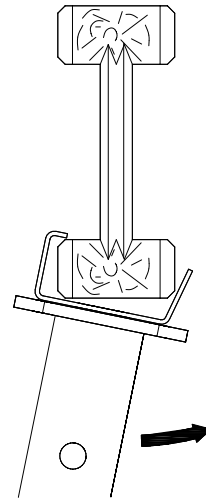

Fig. 12.8

7. Install the transverse girders on the longitudinal girders so that the girder is below the assumed formwork plywood contact points.

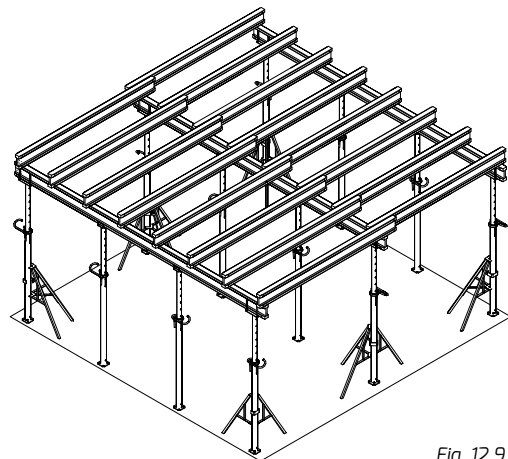

Fig. 12.9

8. Install the plywood sheathing.

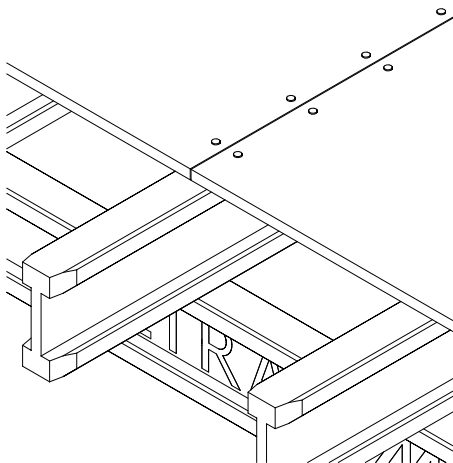

Fig. 12.10

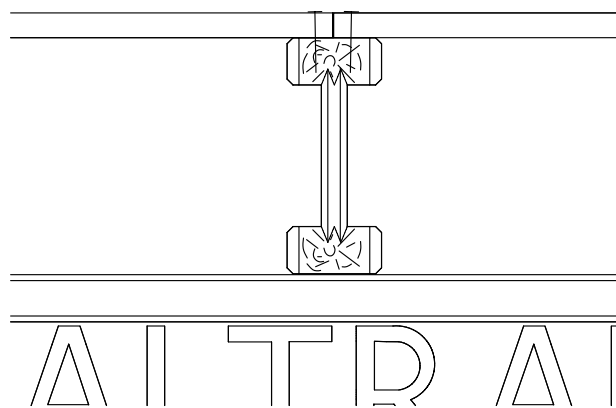

Fig. 12.11

Please remember that the plywood must be fixed to the transverse girders with the nails or screws to protect it from moving during concreting or compacting.

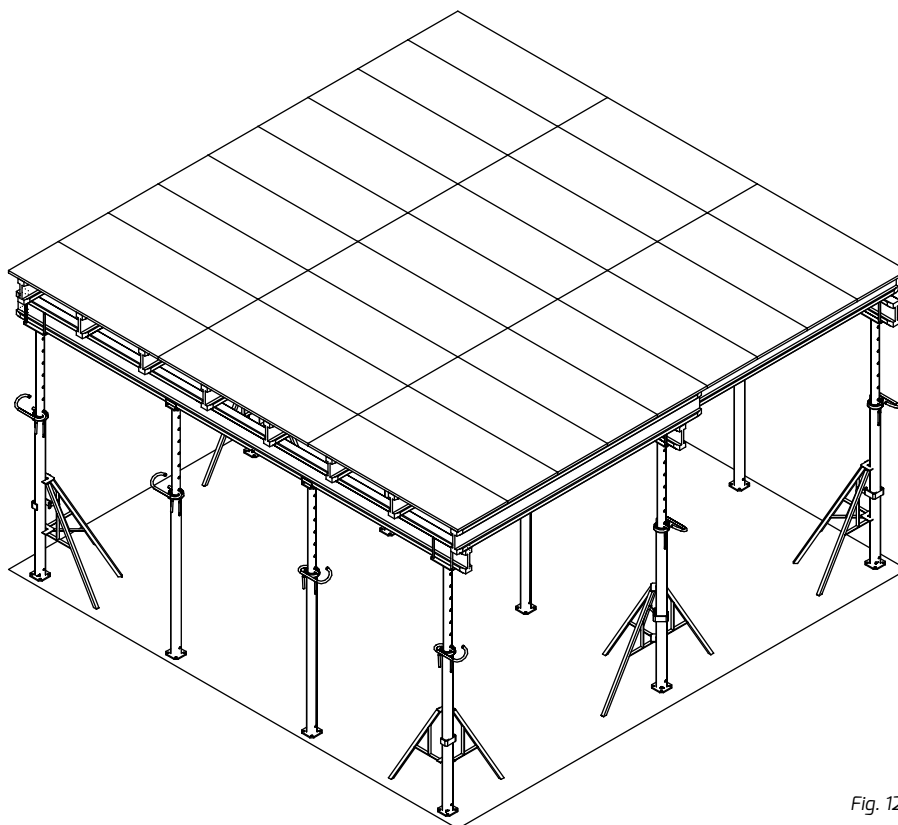

Fig. 12.12

9. Perform final levelling.

10. Before the reinforcing works the plywood should be coated with the antiadhesive liquid.



When erecting the multilevel formwork (binders, lintels) you should start from boarding of the lowest levels as well as installing the beam clamps on the transverse girders.

You should also pay attention to the correct right angles when positioning the formwork to avoid the need to unnecessarily cut the plywood when installing the upper sheathing.

12.1.3. Disassembly of the girder and plywood formwork

Depending on the concrete mixture composition used and the ambient temperature after approx. 7 days you can start to disassemble the ceiling formwork. Please remember that every other row should prop the ceiling up to the 28th day after concreting.

1. Unload the props one by one by rotating the G-hook or unscrewing the nuts with the L-hook.
2. Remove the intermediate props.
3. Lower the boarding by turning the nut by approx. 4 cm, turn the transverse girders and remove them.
4. Turn the other girders one by one and remove the formwork plywood.
5. Remove the longitudinal girders.
6. Fold the props, disconnect the tripod.
7. All elements should be sorted according to their dimensions and stored on the pallets.

NOTE: the Assembly instructions do not replace the EHS instructions on the construction site!

The construction manager is responsible for the assembly of the formwork and checking if it is correctly assembled!

12.2. General rules for the ceiling formwork disassembly

When disassembling the ceiling formwork you should follow the rules below:

- Ceiling formwork should be disassembled so that the concrete surfaces of the ceiling erected and the elements are not scraped or damaged.
- Ceiling formwork that prop the reinforced concrete elements that do not transfer the loads generated by the structure can be removed when concrete reaches its strength that ensures the durability of the surfaces and edges of the concreted structures.
- Ceiling formwork should be disassembled gradually so that a higher number of props is not disassembled at one time. It must be performed in the sequence that ensures that the structure is not stressed.
- When concreting and disassembling the multi-level ceilings it is not acceptable to disassemble the props of the ceiling of the level which is directly under the ceiling concreted at this time.
- The props of the formwork of the next multilevel ceilings which is located below can be removed only partially under all binders and beams but the other props must be left at a distance of $\leq 3,0$ m from each other.
- Formwork of the other multilevel ceilings that are positioned lower can be completely disassembled when concrete reaches (on these ceilings) the strength assumed in the design.
- The complete installation is possible after the actual concrete strength has been specified based on the samples stored in the conditions most similar to curing of the structure concrete.
 - The higher the ratio of load that acts on the given structure part right after the formwork is removed to the total load the given facility part is calculated and designed for, the longer the formwork should be used.
 - When the Portland and metallurgical concrete is taken care of correctly and at the ambient temperature of 15°C you can assume the following ceiling board installation dates: boards, span of up to 2.5 m – at least 5 days or when the half of 28-day concrete strength is achieved; ceilings, span up to 6 m – at least 10-12 days after 70% of the 28-day concrete strength is achieved; larger span ceilings – 28 days.

The tables below indicate the estimated average resistance increase after t days. The values obtained may be provided only for reference.

Estimated Increase in Average Concrete Pressure Resistance in Relation to 28-Day Resistance per PN-EN 1992-1-1 at Curing Temperature of 20°C			
Concrete curing period (days)	Cement classes		
	R	N	S
1	$0.42 * f_{cm,28}$	$0.34 * f_{cm,28}$	$0.20 * f_{cm,28}$
2	$0.58 * f_{cm,28}$	$0.50 * f_{cm,28}$	$0.35 * f_{cm,28}$
3	$0.66 * f_{cm,28}$	$0.60 * f_{cm,28}$	$0.46 * f_{cm,28}$
4	$0.72 * f_{cm,28}$	$0.66 * f_{cm,28}$	$0.54 * f_{cm,28}$
5	$0.76 * f_{cm,28}$	$0.71 * f_{cm,28}$	$0.59 * f_{cm,28}$
6	$0.79 * f_{cm,28}$	$0.75 * f_{cm,28}$	$0.64 * f_{cm,28}$
7	$0.82 * f_{cm,28}$	$0.78 * f_{cm,28}$	$0.68 * f_{cm,28}$
8	$0.84 * f_{cm,28}$	$0.80 * f_{cm,28}$	$0.72 * f_{cm,28}$
9	$0.86 * f_{cm,28}$	$0.83 * f_{cm,28}$	$0.75 * f_{cm,28}$
10	$0.87 * f_{cm,28}$	$0.85 * f_{cm,28}$	$0.77 * f_{cm,28}$

$f_{cm,28}$ - average 28-day resistance depending on the concrete class [MPa]

Estimated Increase in Average Concrete Pressure Resistance in Relation to Average 28-day Resistance of Concrete Based on R Class Cement Cured at 20, 15, 10 and 5°C

Concrete curing period [days]	R Class cement			
	20°C	15°C	10°C	5°C
1	$0.42 * f_{cm,28}$	$0.35 * f_{cm,28}$	$0.28 * f_{cm,28}$	$0.21 * f_{cm,28}$
2	$0.58 * f_{cm,28}$	$0.48 * f_{cm,28}$	$0.39 * f_{cm,28}$	$0.29 * f_{cm,28}$
3	$0.66 * f_{cm,28}$	$0.55 * f_{cm,28}$	$0.44 * f_{cm,28}$	$0.33 * f_{cm,28}$
4	$0.72 * f_{cm,28}$	$0.60 * f_{cm,28}$	$0.48 * f_{cm,28}$	$0.36 * f_{cm,28}$
5	$0.76 * f_{cm,28}$	$0.63 * f_{cm,28}$	$0.51 * f_{cm,28}$	$0.38 * f_{cm,28}$
6	$0.79 * f_{cm,28}$	$0.66 * f_{cm,28}$	$0.53 * f_{cm,28}$	$0.40 * f_{cm,28}$
7	$0.82 * f_{cm,28}$	$0.68 * f_{cm,28}$	$0.55 * f_{cm,28}$	$0.41 * f_{cm,28}$
8	$0.84 * f_{cm,28}$	$0.70 * f_{cm,28}$	$0.56 * f_{cm,28}$	$0.42 * f_{cm,28}$
9	$0.86 * f_{cm,28}$	$0.71 * f_{cm,28}$	$0.58 * f_{cm,28}$	$0.43 * f_{cm,28}$
10	$0.87 * f_{cm,28}$	$0.73 * f_{cm,28}$	$0.59 * f_{cm,28}$	$0.44 * f_{cm,28}$

$f_{cm,28}$ -average 28-day resistance depending on the concrete class [MPa]



Ceiling formwork disassembly must be accompanied by the appropriately qualified persons.

12.3. Props and girders spacing selection criteria

The ceiling formwork which is correctly designed allows to reduce the assembly time and ensures safety during concreting.

The equipment necessary to make the ceiling prop can be selected with the EuroSchal computer software or in an analytical manner presented below.

NOTE: the Assembly instructions do not replace the EHS instructions on the construction site!

The construction manager is responsible for the assembly of the formwork and checking if it is correctly assembled!

Permissible prop load capacity (kN) for the given prop height											
Weight (kg)	15.6	17.5	25.0	17.0	23.0	23.8	31.6	34.6	36.4	15.4	18.4
Index	A0006300	A0006350	A0006410	A0004300	A0004350	A0004400	A0004450	A0004500	A0004550	A0121300C	A0121350C
Support working height (m)	5.50								20.0		
	5.40								21.5		
	5.30								22.5		
	5.20								24.0		
	5.10								25.0		
	5.00								20.0	26.0	
	4.90								21.0	27.0	
	4.80								22.0	28.5	
	4.70								23.0	30.0	
	4.60								24.5	31.5	
	4.50							20.0	26.0	33.5	
	4.40							20.5	27.0	35.0	
	4.30							21.0	28.5	35.0	
	4.20							21.5	30.5	35.0	
	4.10			20.0				22.5	32.0	35.0	
	4.00			20.5			20.0	23.0	34.0	35.0	
	3.90			21.5			22.0	24.5	35.0	35.0	
	3.80			23.5			23.5	25.0	35.0	35.0	
	3.70			25.0			25.0	26.5	35.0	35.0	
	3.60			26.5			26.0	27.0	35.0	35.0	
	3.50		14.5	28.5		20.0	28.0	28.5	35.0	35.0	15.0
	3.40		15.5	30.5		22.0	29.5	31.5	35.0	35.0	17.0
	3.30		17.0	33.0		24.0	31.0	33.0	35.0	35.0	19.0
	3.20		18.5	35.0		25.0	31.5	35.0	35.0	35.0	21.0
	3.10		20.0	35.0		27.5	32.5	35.0	35.0	35.0	23.0
	3.00	18.5	21.5	35.0	20.0	29.0	35.0	35.0	35.0	35.0	18.0
	2.90	20.5	23.0	35.0	21.5	30.0	35.0	35.0	35.0		20.0
	2.80	23.0	24.0	35.0	23.0	31.0	35.0	35.0	35.0		21.5
	2.70	25.5z	25.5	35.0	25.0	32.0	35.0	35.0	35.0		23.0
	2.60	27.5	27.0	35.0	26.0	34.0	35.0	35.0			25.0
2.50	30.0	28.5	35.0	27.0	35.0	35.0	35.0			26.5	
2.40	32.0	30.0	35.0	28.0	35.0	35.0				28.0	
2.30	34.5	31.5	35.0	29.0	35.0	35.0				30.0	
2.20	34.5	33.0		30.5	35.0					31.5	
2.10	34.5	34.5		32.0	35.0					33.0	
2.00	34.5	36.0		35.0	35.0					35.0	
1.90	34.5			35.0						35.0	
1.80	34.5			35.0						35.0	
1.75	34.5			35.0						35.0	

The minimum prop load capacity is 20 kN in the whole height range

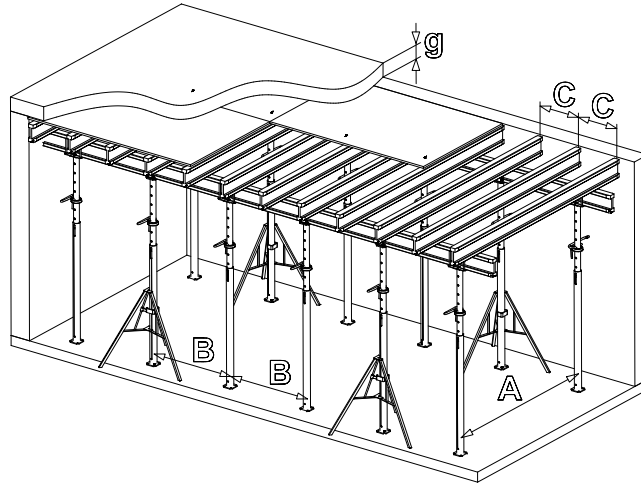

Fig. 12.13

		g – concrete thickness														
		14 cm	16 cm	18 cm	20 cm	22 cm	24 cm	26 cm	28 cm	30 cm	40 cm	50 cm	60 cm	70 cm	80 cm	
A [m] – longitudinal girders spacing																
B [m] – ceiling props spacing																
Q [kN] – total load kN/prop																
C – transverse girders spacing	0.4 m	A	3.30	3.20	3.10	3.00	3.00	3.00	2.80	2.80	2.70	2.50	2.30	2.20	1.90	1.70
		B	1.20	1.15	1.10	1.05	0.95	0.90	0.90	0.85	0.80	0.65	0.60	0.50	0.50	0.50
		Q	21.34	21.75	21.93	21.89	21.29	21.57	21.45	21.49	20.76	20.69	21.87	20.87	20.99	21.43
	0.5 m	A	3.10	3.00	2.90	2.80	2.70	2.70	2.60	2.60	2.50	2.30	2.10	2.00	1.90	1.70
		B	1.30	1.20	1.15	1.10	1.05	1.00	0.95	0.90	0.90	0.75	0.65	0.55	0.50	0.50
		Q	21.72	21.28	21.44	21.41	21.18	21.57	21.02	21.13	21.62	21.96	21.64	20.87	20.99	21.43
	0.625 m	A	2.80	2.70	2.70	2.60	2.50	2.50	2.40	2.40	2.30	2.10	2.00	1.90		
		B	1.45	1.35	1.25	1.20	1.15	1.10	1.05	1.00	0.95	0.80	0.65	0.60		
		Q	21.88	21.54	21.70	21.68	21.48	21.97	21.45	21.67	21.00	21.39	20.61	21.63		
	0.75 m	A	2.70	2.60	2.50	2.50	2.40	2.30	2.30	2.20	2.20	2.00	1.90			
		B	1.50	1.40	1.35	1.25	1.20	1.15	1.10	1.10	1.00	0.85	0.70			
		Q	21.83	21.51	21.70	21.72	21.51	21.13	21.53	21.85	21.14	21.64	21.08			
q [kN/m ²]			5.39	5.91	6.43	6.95	7.47	7.99	8.51	9.03	9.61	12.73	15.85	18.97	22.09	25.21

The A and B set-up values are maximum values. You can use the A and B values which are smaller than those specified in the table.

$$Q = q \cdot A \cdot B \quad q = w_s + w_b + w_d \quad w_s = 0.25 \text{ kN/m}^2 \quad w_b = 0.26 \text{ kN/m}^2 \cdot g \quad w_d = 0.2 \cdot w_b \quad \text{but } \geq 1.5 \text{ kN/m}^2 \text{ and } \leq 5.0 \text{ kN/m}^2$$

w_s – constant load

w_b – concrete load

w_d – instantaneous load

Wooden formwork girder, height $h = 200 \text{ mm}$ (H-20):

- permissible shearing force - 11 kN (max. reaction on the prop - 22.0 kN),

- permissible bending moment - 5.0 kNm

Waterproof plywood, smooth on both sides, #21 mm: modulus of elasticity $E_{90} = 7000 \text{ MPa}$

Plywood #21 permissible q load values qd [kN/m ²]		
C – transverse girders spacing	0.4 m	34.3
	0.5 m	26.5
	0.625 m	21.0
	0.75 m	16.0

NOTE: When using the props whose load capacity is smaller than 22 kN their optimal spacing should be determined in an analytical manner according to the relation below:

$$B_0 \leq \frac{Q_z}{[q \cdot Az]}$$

B_0 – maximum ceiling props spacing determined in an analytical manner;

Q_z – permissible load capacity of the prop used with the given expansion of this prop (prop load capacity table)

q – surface load resulting from the g concrete thickness (table above)

Az – assumed maximum longitudinal girders spacing, where $Az < A$

NOTE: the Assembly instructions do not replace the EHS instructions on the construction site!

The construction manager is responsible for the assembly of the formwork and checking if it is correctly assembled!

12.4. Alternative methods of shoring of the girder and plywood ceiling formwork

The ceiling formwork can also be propped with the shoring towers built of the ROTAX Plus scaffolding system elements. They are installed in the bay measuring 0.73 x 0.73 and 1.09 x 1.09. The shoring towers can be connected with each other in any manner by using the ROTAX Plus system elements and the standard pipes, and couplings. It is possible to install the system steel brackets (0.36 m, 0.73 m, 1.09 m) which are used for shoring the working platforms. All connections are made through the stand hole discs.

S10 shoring towers are another type of the elements used for shoring the ceiling formwork. They consist of the steel frames with the spacing of 1.0 x 1.0 m and the height adjusted in 50 cm increments. The height is smoothly adjusted by changing the expansion of the feet and adjustable heads. The tower stiffness in both perpendicular directions is ensured by the rule of rotating the basic frames by 90° and the vertical bracing installed with the special catches. It should be also remembered that the vertical bracings connect the tower structure to make an inseparable element which is particularly important as regards the vertical transport with the construction cranes. All elements of the S10 shoring tower are hot dip galvanised. To increase the stiffness of the structure that props the ceiling the single sets of the S10 and Rotax Plus towers can be connected with each other by using the horizontal elements (e.g. standard pipes and normal couplings) and the skew elements (bracings made of the standard pipes and rotary couplings). The connection layout depends on the tower arrangement and their height and it should be determined for the individual cases.

For tower:	Position height [m]	Permissible load per stand [kN]	
		Without wind load	With wind load
Not fastened at the top	5.50	52.0	43.0
	7.50	51.6	41.0
	> 7.50	Requires structural analysis	Requires structural analysis
Fastened at the top	5.50	53.0	52.4
	7.50	53.0	51.0
	12.50	52.4	48.0
	20.00	50.4	Please consult the producer

The shoring towers are used when installing the formwork for the monolithic construction structures and to prop the prefabricated construction props during the assembly. Moreover, the towers are used for erecting the shoring structures for the working platforms, protective platforms and other load bearing structures.

Below is an example presenting the ceiling propped with the S10 shoring towers and the shoring towers made of the ROTAX Plus scaffolding system elements.

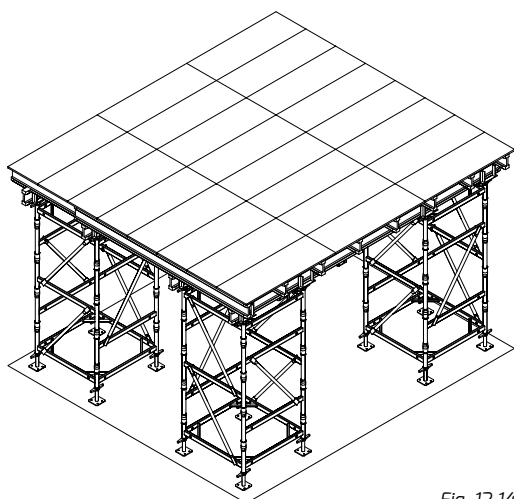

Fig. 12.14

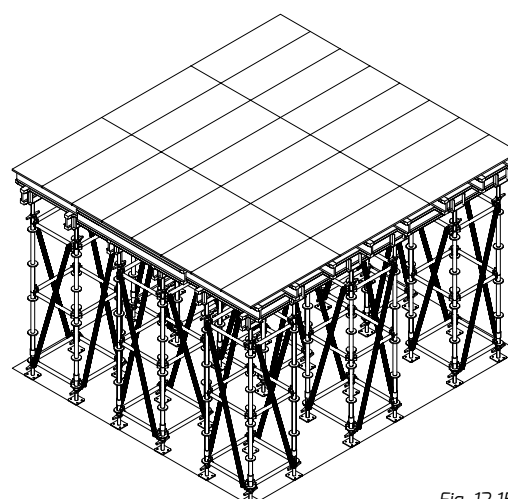

Fig. 12.15

13. SAMPLE BINDER FORMING

The binders may be formed in a few manners. Below are several examples.

- Binder formed with the beam clamp (A0026000), formwork plywood, formwork girders (A0010...) and the formwork props.

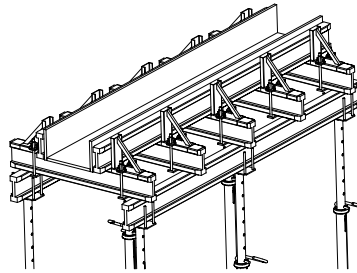

Fig. 13.1

- Binder formed with the beam clamp (A0026000), formwork plywood, square timbers and the formwork props.

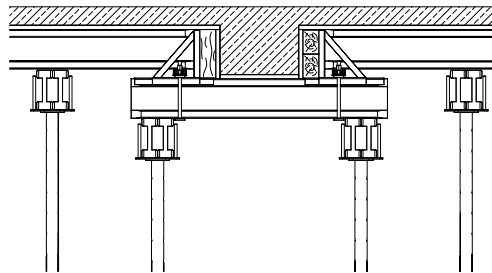

Fig. 13.2

- Binder formed with the edge catch (A0910001), formwork plywood, formwork girders (A0010...), formwork bowstrings (A0815...), flange nuts (A2510...) and the formwork props.

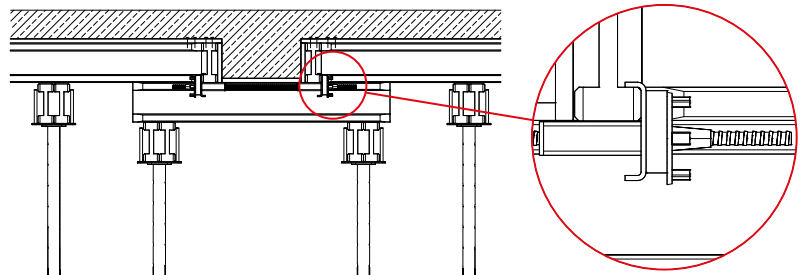

Fig. 13.3

- Binder formed with the shuttering boards (A02... or A04...), formwork bowstrings (A0815...), flange nuts (A2510...), square timbers, formwork girders (A0010...) and the formwork props.

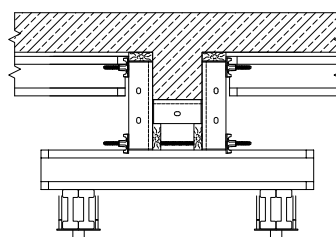

Fig. 13.4

When forming the binders or lintels on the building external edges where the props must be positioned on the level edge the structure should be anchored to the ceiling with the stays. A stay protects the structure against tilting of the boarding outwards. The structure should be anchored to the ceiling with the expandable anchors or the concreted steel grips.

NOTE: the Assembly instructions do not replace the EHS instructions on the construction site!

The construction manager is responsible for the assembly of the formwork and checking if it is correctly assembled!

14. ALUSTROP CEILING FORMWORK

The ALUstrop ceiling formwork produced by ALTRAD-MOSTOSTAL consists of aluminium boards and ceiling props. The aluminium board structure is featured by very light weight and durability. The frame is covered with the special water-proof plywood 10 mm thick. The shape of the aluminium sections as the board frame protects it against contamination by concrete leaking where these boards contact each other. The variety of the system boards makes it possible to adapt the set to each ceiling. And the gaps between the existing walls can be easily filled with the expandable board or filling plywood 21 mm thick. The plywood is installed on special girders (compensating, transverse) or square timbers.

The shuttering boards are propped by such elements as the construction props fitted with the shoring heads.

ALUstrop can be installed up to 3,5 m high without the need to use the special jacks. When the height is greater you should use the mobile scaffoldings. The maximum ceiling thickness is 50 cm.

The system includes also the elements that protect the employees against falling from the height.

Speed of the works completion is greatly influenced by the professional preparation in terms of organisation and logistics. When the task completed is correctly divided into the stages and the optimal props spacing is selected the outages on the construction site are avoided and the dynamics of the works completed is increased.

All components of the system are presented in the formwork elements catalogue.

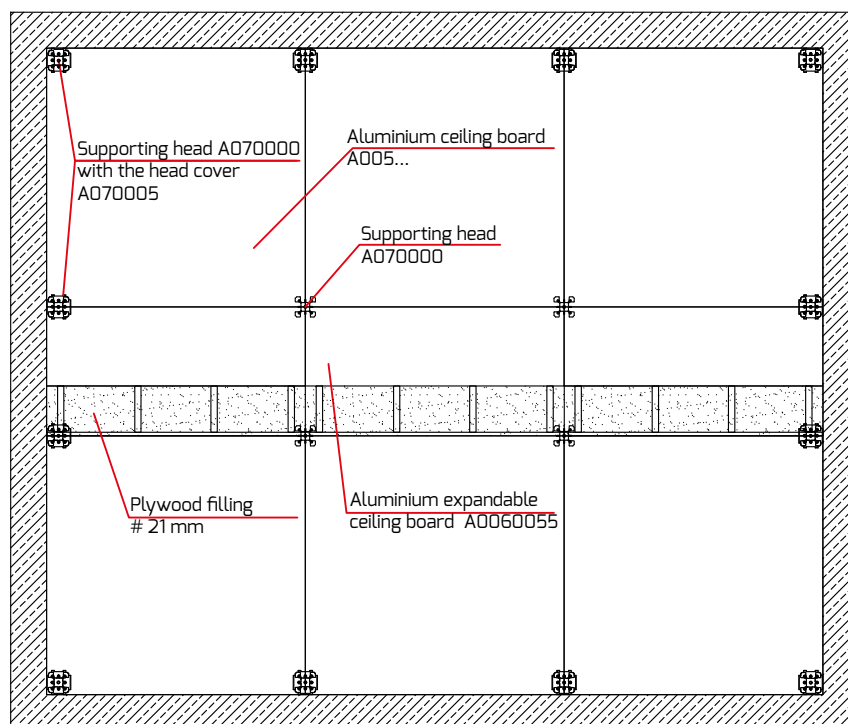

Fig. 14.1



Before the assembly the employees should be trained in the peculiarities of the ceiling formwork assembly and disassembly.

14.1. Permissible thickness of the ceiling erected with the ALUstrop formwork

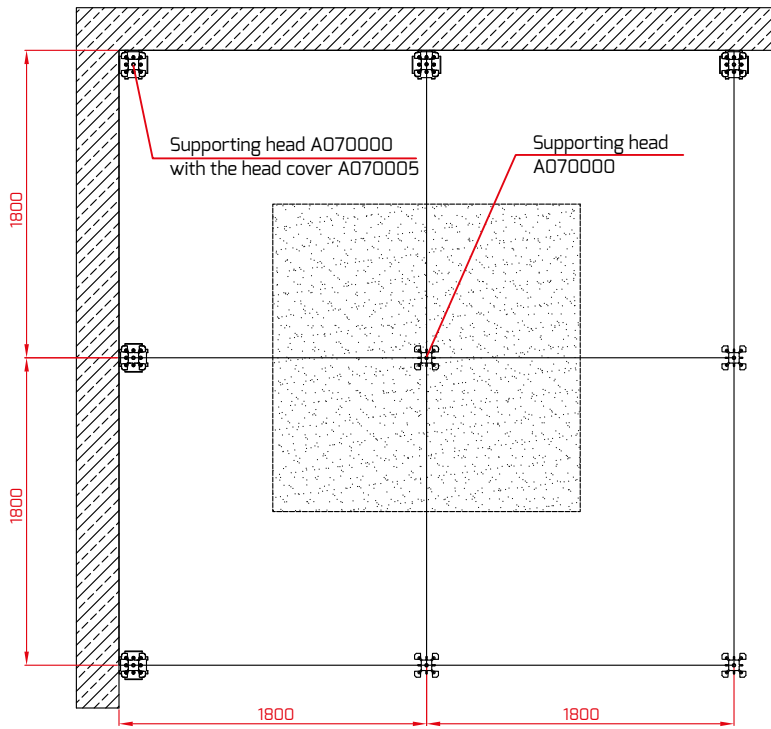

Fig. 14.2

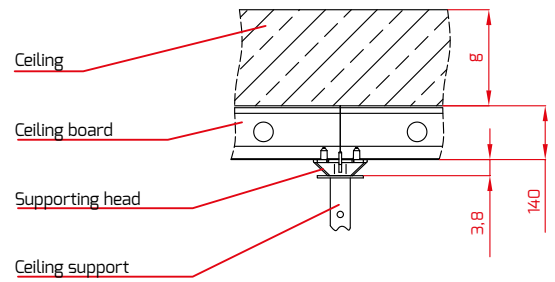

Fig. 14.3

Permissible forces in the props for the given ceiling thickness (maximum surface area affecting the prop $A = 3.24 \text{ m}^2$ – boards $1.8 \text{ m} \times 1.8 \text{ m}$)														
Ceiling thickness	g	[cm]	14	16	18	20	22	24	26	28	30	40*	45*	50*
Surface load	q	[kN/m ²]	5.3	5.8	6.4	6.9	7.4	7.9	8.4	9.0	9.5	12.7	14.2	15.8
Force in prop	Q	[kN]	17.2	18.9	20.6	22.3	24.0	25.7	27.3	29.0	30.9	20.5	23.0	25.6

* - with the intermediate prop

* Diagram – intermediate prop.

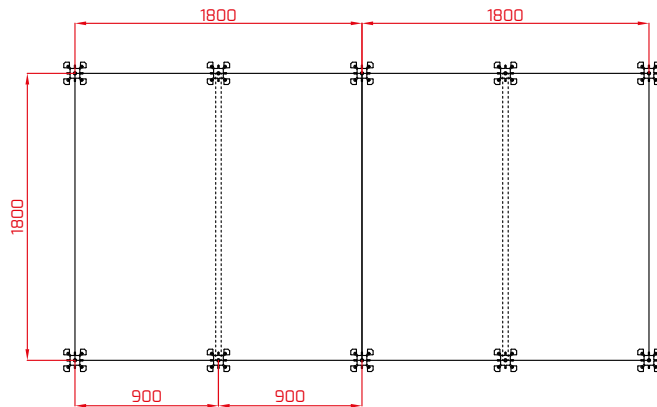

Fig. 14.4

Permissible forces in the props for the given ceiling thickness (maximum surface area affecting the prop $A_2 = 1.62 \text{ m}^2$ – boards $0.9 \text{ m} \times 1.8 \text{ m}$)														
Ceiling thickness	g	[cm]	14	16	18	20	22	24	26	28	30	40	45	50
Surface load	q	[kN/m ²]	5.3	5.8	6.4	6.9	7.4	7.9	8.4	9.0	9.5	12.7	14.2	15.8
Force in prop	Q	[kN]	8.6	9.5	10.3	11.1	12.0	12.8	13.7	14.5	15.5	20.5	23.0	25.6

NOTE: the Assembly instructions do not replace the EHS instructions on the construction site!

The construction manager is responsible for the assembly of the formwork and checking if it is correctly assembled!

$$Q = q \cdot A$$

$$q = w_s + w_b + w_d \quad w_s = 0,18 \text{ kN/m}^2 \quad w_b = 26 \text{ kN/m}^3 \cdot g \quad w_d = 0,2 \cdot w_b \quad \text{ale } \geq 1,5 \text{ kN/m}^2 \text{ i } \leq 5,0 \text{ kN/m}^2$$

w_s - permanent load w_b - concrete load w_d - instantaneous load

Maximum L filling width when using the plywood #21 mm thick when considering the permissible bending limit which cannot be exceeded (according to DIN 18202)															
Ceiling thickness	g	[cm]	14	16	18	20	22	24	26	28	30	35	40	45	50
For line 5 of DIN18202	L_1	[cm]	85	80	80	75	75	70	70	70	65	65	60	55	55
For line 6 of DIN18202	L_2	[cm]	70	70	65	65	60	60	55	55	55	50	45	45	40

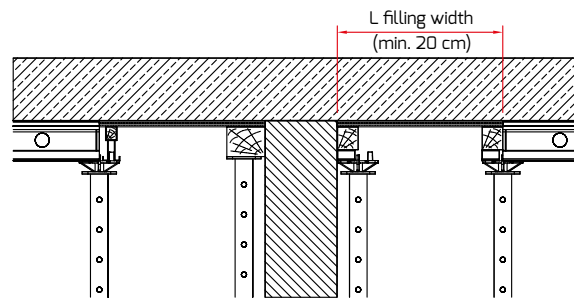

Fig. 14.5

14.2. ALUstrop ceiling formwork assembly

Before the assembly collect all elements in the formwork assembly zone. During the assembly you should mainly use the boards of the following dimensions: 180 x 180 cm. It ensures the reliable assembly and disassembly time reduction. Before using the boards all surfaces which will directly contact concrete have to be coated with the Separbet or Betomil antiadhesive liquid.

As regards rooms with large spans it is recommended to use the compensating strip between the ceiling shoring structural elements in the middle of its span. The strip should be made of plywood or square timber supported on the construction props. Using the compensating strip is very important when it is necessary to use the secondary props when the boarding is moved on the higher levels.

Distance between the compensating strips and between the compensating strip and the wall prop cannot exceed 3 m.

Distance of the props positioned along the compensating strip cannot exceed 1.5 m. For ceilings thicker than 30 cm it is recommended to reduce prop spacing.

1. Position the ceiling props fitted with the heads with the head covers in (A0070000) the board corners (A0070005). Below drawing shows two methods of assembling cross head on the ceiling support. First one is to fully insert cross head into the ceiling support and secure connection. Second one is to partly remove cross head from the ceiling support and secure connection using rod or bolt (all drawings in the Assembly Manual show the first method). Before the assembly of each prop you should pre-determine its basic height by using the G-hook lock inserted in the appropriate system hole of the upper and mobile pipe part. To precisely adjust the prop height you should use the nut which should be appropriately rotated. Then to protect the props against the possible falling you should use the tripods. The recommended ratio of the tripods installed to the number of props is 1:3. The props fitted with the head and the head cover (A0070005) should be used in the corners of the facilities erected. Figures 14.7, 14.8 and 14.9 show various application concepts.

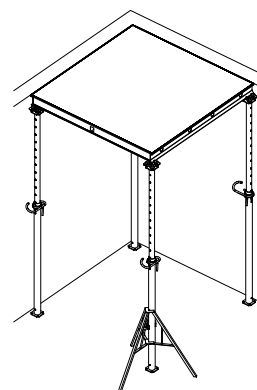

Fig. 14.6

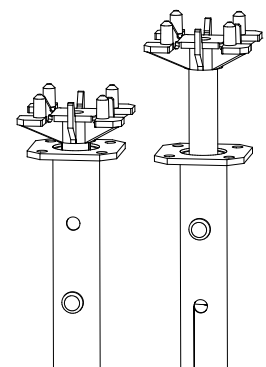

Fig. 14.6a

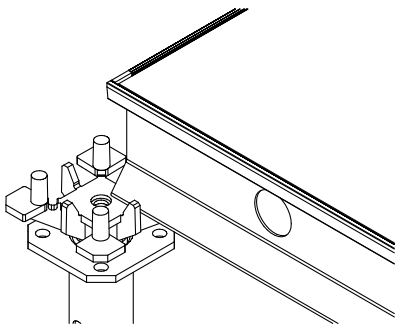

Fig. 14.7 – Prop - shoring head located where four boards contact each other

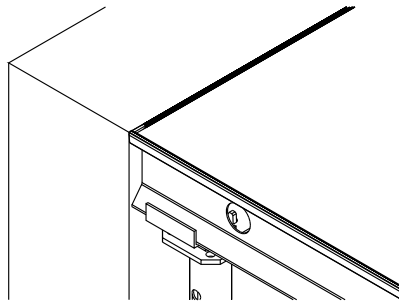

Fig. 14.8 – Prop - shoring head with the head cover located in the wall corner

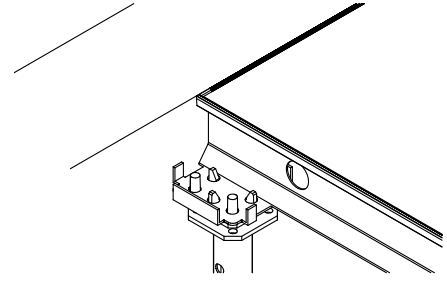

Fig. 14.9 – Prop - shoring head with the head cover located at the building wall

2. The assembly should be continued by installing the other boards according to the prepared plan. The boards should be hung at an angle using the heads (fig. 14.10) of the existing structure and then they should be lifted to the level where the ceiling is installed and propped with the props (fig. 14.11). You can lift boards using the props or mounting rod assembly (A0078005).

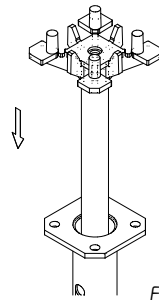

Fig. 14.10

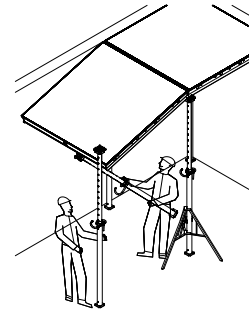

Fig. 14.11

3. On each edge of the ceiling installed which is not fitted with the railing you should install a barrier that protects the employees against falling from the height. To do this you should use the head with the post socket (fig. 14.12 and 14.15) and the working platform posts (fig. 14.14) and the toeboard grips (fig. 14.16).

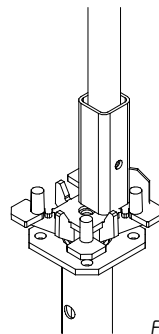

Fig. 14.12

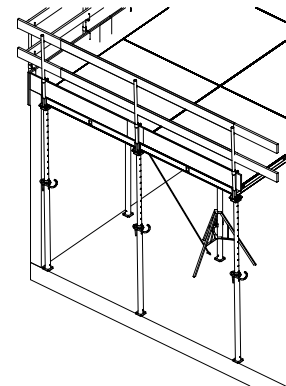

Fig. 14.13

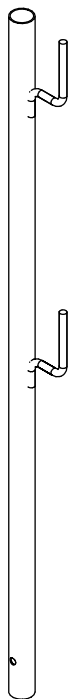

Fig. 14.14

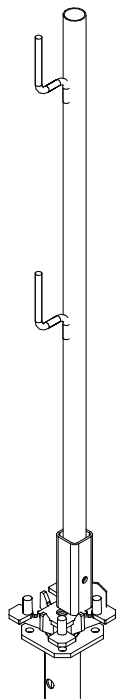

Fig. 14.15

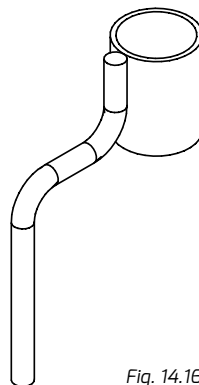

Fig. 14.16

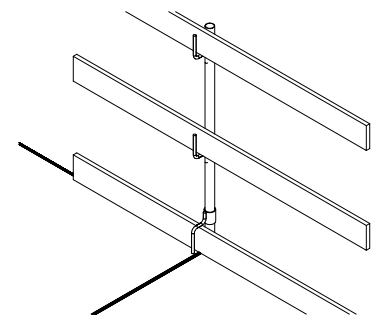

Fig. 14.17

NOTE: the Assembly instructions do not replace the EHS instructions on the construction site!

The construction manager is responsible for the assembly of the formwork and checking if it is correctly assembled!

4. When the board outline protrudes beyond the ceiling border you should install the railings by using the railing posts (A003...) (fig. 14.18). Fasten (with nails) the wooden square timber 14x14x30 cm to the bottom post arm so that the post can be installed by clamping its movable parts on the formwork plywood surfaces. The system also includes the corner post which allows for the installation of the planks in the ceiling formwork corner.

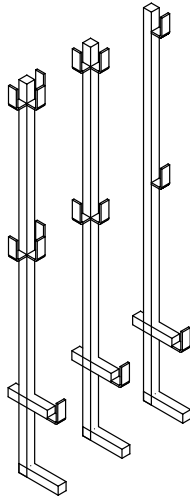

Fig. 14.18

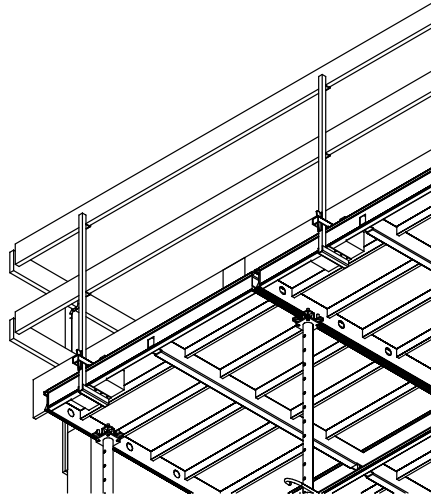

Fig. 14.19

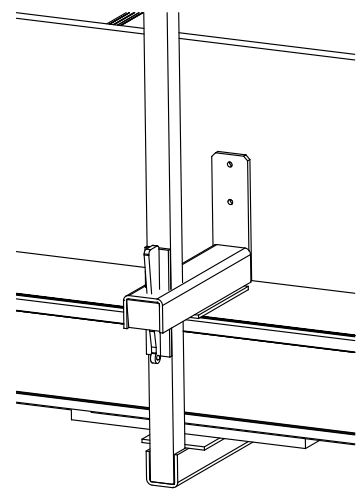

Fig. 14.19a

5. The outermost boards should be connected with the standard pipe $\varnothing 48.3$ mm (E4405...) installed through the holes in the framing section. The shuttering board should be anchored to the ceiling with the stays. A stay protect the shuttering boards against moving outwards. When anchoring the boards to the ceiling you should use the expandable anchors or concreted steel grips.

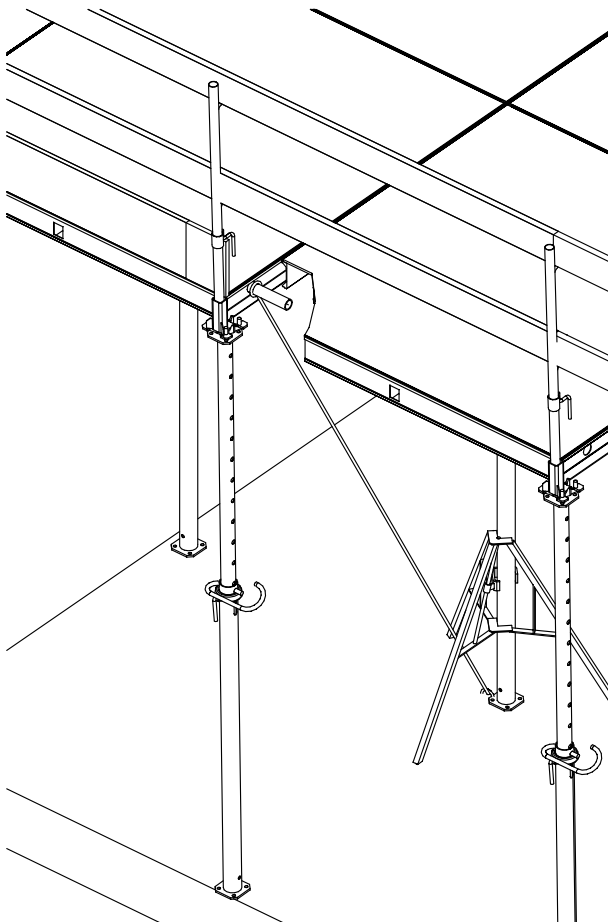

Fig. 14.20

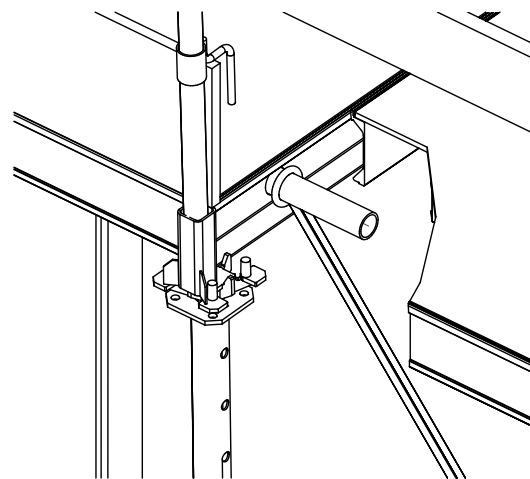

Fig. 14.20a



The boards positioned on the brackets (protruding more than 10 cm beyond the outermost prop axis) should be unloaded with the stays located at the opposite side of the outermost prop at a distance not greater than the bracket protrusion.

The stay connects the pipe $\varnothing 48,3$ mm installed through the framing section holes fixed on the board with the anchor installed in the ceiling (fig. 14.20).

When the ceiling is 50 cm thick the board 90x180 cm may protrude approximately 90 cm beyond the outermost prop axis (half of 180 cm). In this case when concreting you should remember about the direction in which the concrete mixture should be poured. The mixture should be laid from the middle of the ceiling and only when the entire ceiling surface is evenly loaded i.e. at the next stages you can lay concrete on the protruding board parts.

6. The ALUstrop ceiling formwork allows for the boarding of the surfaces whose dimensions are the multiple of 15 cm. The system also includes the expandable shuttering board (A0060055) which can be used to fill the space of 55 - 90 cm (fig. 14.21). The possible gap which may be created should be filled with the formwork plywood 21 mm thick.

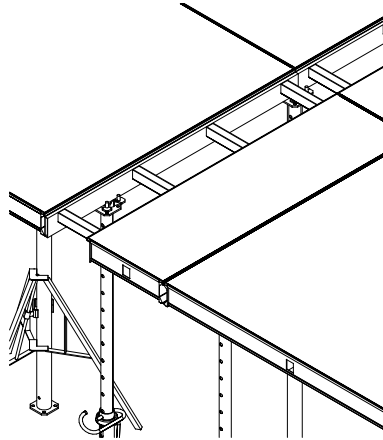

Fig. 14.21

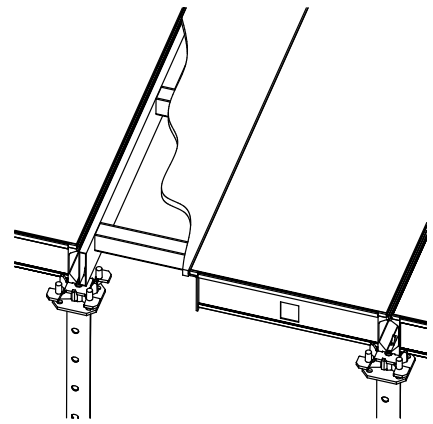

Fig. 14.21a

7. The expandable shuttering board may be replaced with the other board (larger than the width of the space which is not filled) and the compensating girders (A0080...) 180 or 90 cm long. Plywood 21 mm thick should be installed on the girders (fig. 14.22 and 14.23). You should then complete the additional construction props.

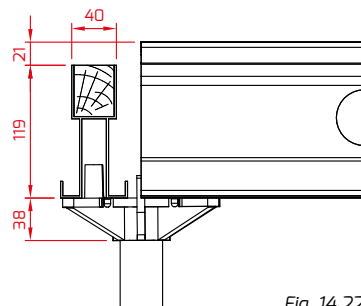

Fig. 14.22

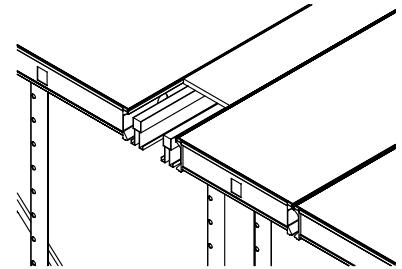

Fig. 14.23

8. To fill the gap in a different manner you should use the wooden square timbers 80 mm high positioned on the spacing head superstructures (A0075000) (fig. 14.24 and 14.25).

The props positioned on the ceiling edge should be protected against falling.

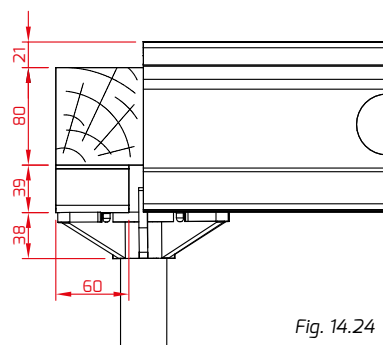

Fig. 14.24

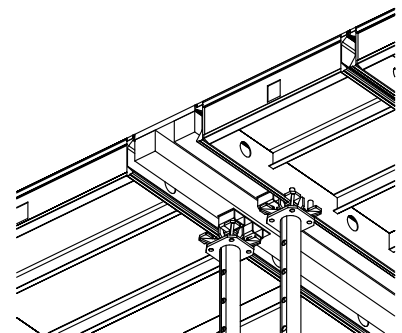

Fig. 14.25

NOTE: the Assembly instructions do not replace the EHS instructions on the construction site!

The construction manager is responsible for the assembly of the formwork and checking if it is correctly assembled!

9. When the distance between the girders is larger than the permissible limit (which depends on the ceiling thickness and the permissible possible deformation - see table 3) then you should additionally prop the formwork plywood in the middle of its span. It can be propped with the construction props and the wooden square timber (fig. 14.26).

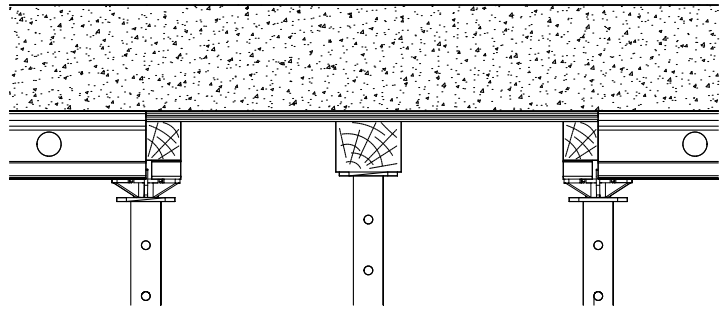

Fig. 14.26

10. When boarding the ceiling the formwork within the posts and other elements inserted in the ceiling should be made of the compensating girders 0.90 or 1.80 m and the transverse girders (A0081090) (fig. 14.27 and 14.28). By using these elements you can make a grate which can be covered with the plywood 21 mm thick and appropriately cut.

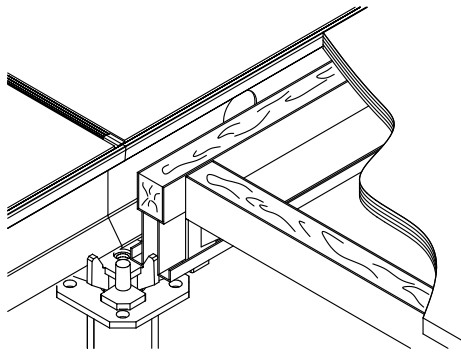

Fig. 14.27

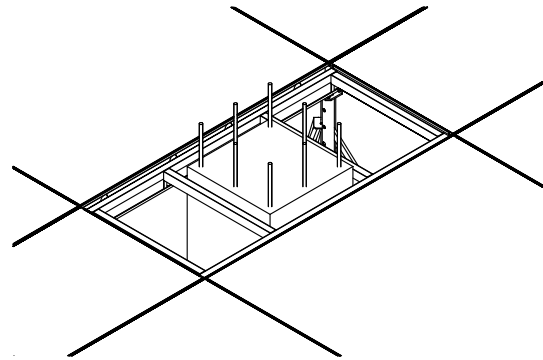

Fig. 14.28

11. When the binder has to be made you can use the wall shuttering boards and the connecting elements. The boards can be propped with the conventional wooden girders and construction props. When the beam clamps are used the shuttering boards will be positioned vertically (fig. 14.29).

Chapter 13 of this manual presents other binder forming examples.

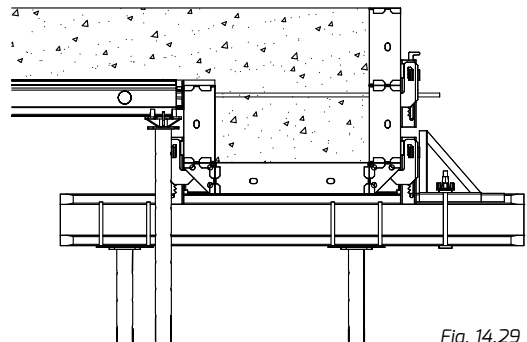

Fig. 14.29

12. To build a formwork for the outermost ceiling and ring edges on the existing walls you should use the ring support (A0030000). The support is anchored to the existing wall and the wooden plank which is max. 40 mm thick is pressed to it. Where possible, it is recommended to install the anchors through the whole wall thickness using the formwork braces (A0815...) and flange nuts (A2510...). The support interacts with the working platform post (A0970002).

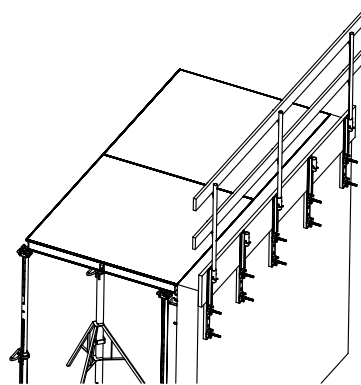

Fig. 14.30

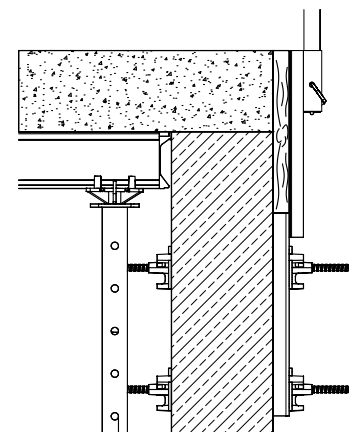

Fig. 14.31

14.3. ALUstrop ceiling formwork disassembly

Ceiling formwork disassembly should start from the removal of supplementary inserts or slide-away ceiling boards. It will make the removal of other ceiling boards easier.

The individual boards should be removed in the reverse order of their installation:

- loosen adjusting nuts of the ceiling supports so that the ceiling board plywood is “released” from the concrete ceiling plane;
- remove the tripods;
- lower the support;
- remove the ceiling board.

When the equipment must be quickly repositioned on the higher level you must leave the auxiliary supports. If possible, the auxiliary supports should be positioned where the auxiliary supports of the lower level are installed. It is recommended to use the compensating strip as an auxiliary support.

During disassembly of boards do not allow their uncontrolled fall or rotation, which occurs when the board is supported on the cross heads only on one edge (the other two ceiling supports are already disassembled). Producer is not responsible for damages caused by the user’s fault

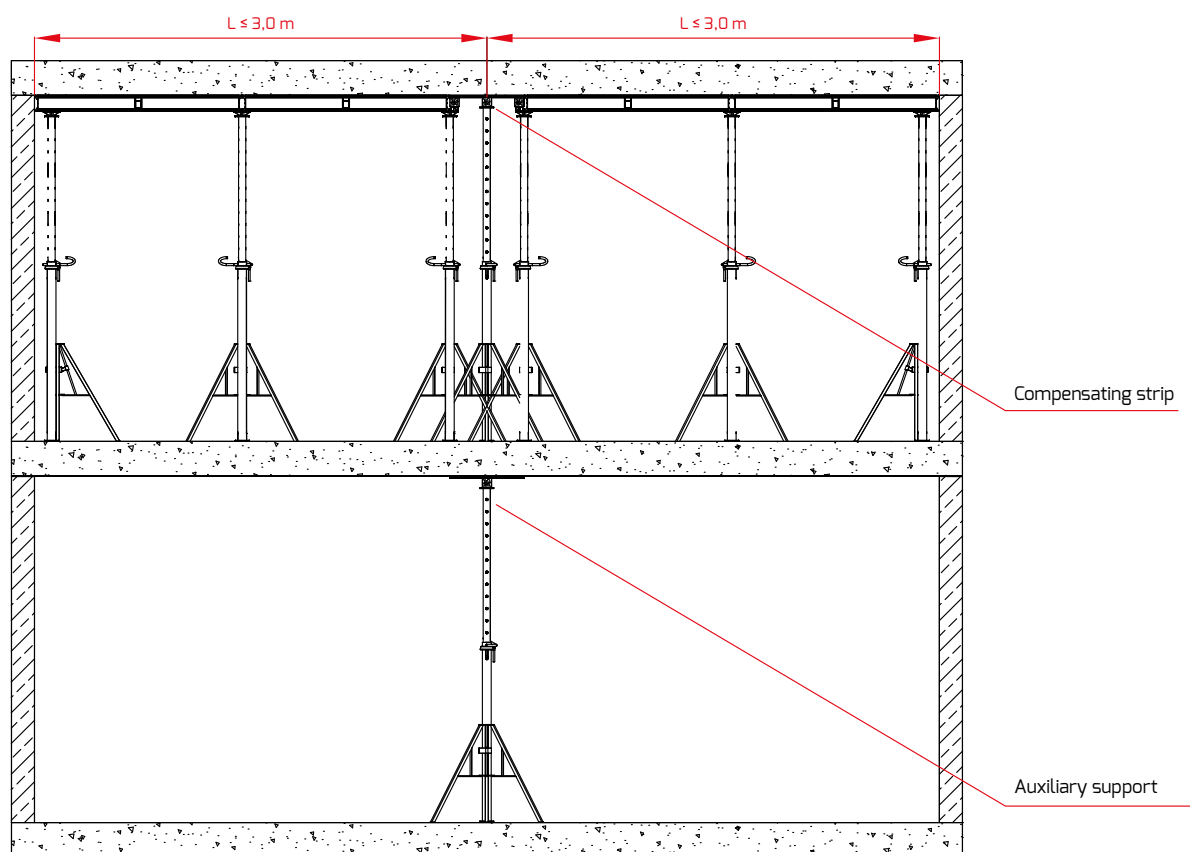

Fig. 14.32

The general rules for the assembly of the ceiling formwork are presented in item 12.2 of this manual.



Ceiling formwork disassembly must be accompanied by the appropriately qualified persons.

NOTE: the Assembly instructions do not replace the EHS instructions on the construction site!

The construction manager is responsible for the assembly of the formwork and checking if it is correctly assembled!

14.4. Maintenance of the ALUstrop ceiling formwork components.

Keeping the shuttering boards clean has a decisive impact on their durability. Before each next use the plywood and the side sections should be coated with the antiadhesive liquid. It will significantly reduce the time needed to clean the boards after removing the ceiling formwork.

The structure of the section used which frames the plywood sheathing protects the board surface against contamination. The protruding section edges act as a "throating" and reduce the contamination.

The proper board operation limits the cleaning cycle range only to the small side surfaces.

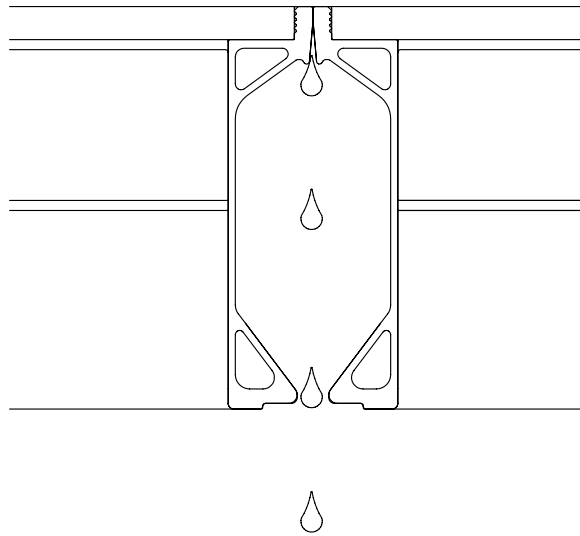

Fig. 14.33

Owing to the material the ceiling boards are made of you should carefully transport and disassemble the boards. Avoid hitting the boards with hard objects and throwing them from the height.



ALTRAD-MOSTOSTAL Spółka z o.o.
ul. Starzyńskiego 1, 08-110 Siedlce - Poland
Tel. +48 25 644 72 84 - Tel. +48 25 644 82 93 - Email: handlowy@altrad-mostostal.pl
www.altrad-mostostal.pl

05.2023

