

DESIGN TILES SPECIFICATION

CEWOOD Design tiles are suitable for installation on ceilings and walls, where they serve as both acoustic panels and decorative elements. They are available in a wide range of shapes and colours, making them adaptable to different design requirements. Tile dimensions are subject to defined limits, but the tiles can be produced in various shapes.

Dimensional limits

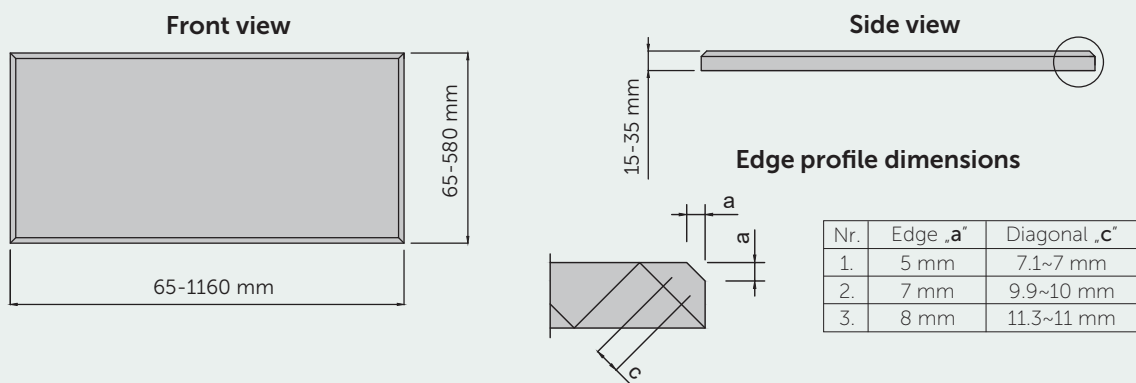

Technical specifications

Wood wool width	1.0 mm
Tile thickness	15 mm; 25 mm; 35 mm; other available upon request
Colours	natural painted, white, black, grey and any shade in RAL or NCS system upon request
Profiles	P5; P7; P8; other edge profiles upon request
Fire reaction class	B-s1, d0

Top-selling shapes

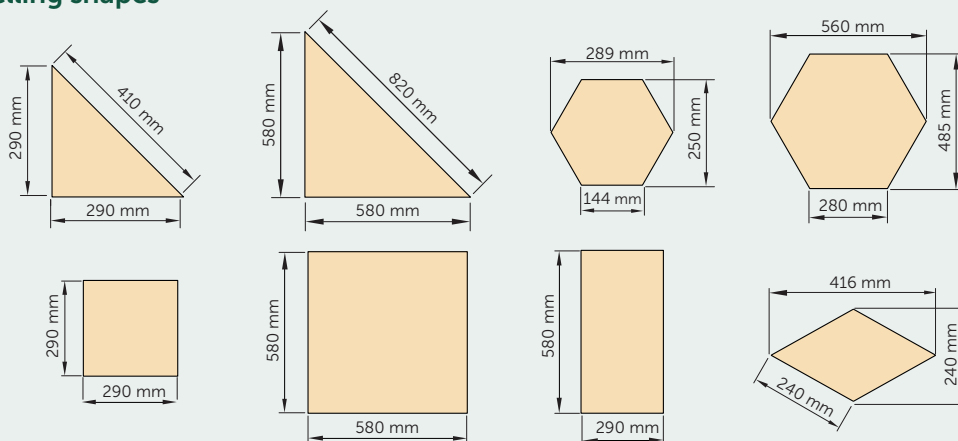

Design tiles are installed by gluing. Detailed instructions can be found in the "Downloads" section under the file "Glue selection instructions and surface preparation". For more massive panels, for example in the size of 580x580 mm, especially when mounted on ceilings, additional screw fixing is recommended. In this case, refer to the file "Screw installation guidelines for panels".