

CEWOOD INSPECTION HATCHES

CEWOOD manufactured inspection hatches are available at various sizes. They are built in elements into the ceiling panels without any additional frame. Hatches are designed for access to any kind of communications, that are located behind the ceilings. Panels with inspection hatches are mounted with the same guidelines as the standard acoustic ceiling panels. Hatch door is fully removable and reinsertable at any moment necessary. Visually, the hatches merge with the ceilings and form a smooth ceiling surface.



Technical properties

Wood wool width	1.0 mm; other wood wool upon request
Panel thickness	25 mm; 35 mm
Size (standard panels)	1200x600 mm; 600x600 mm
Size (for suspended ceiling)	595x595 mm; 1195x595 mm
Colours	natural painted, white, black, grey and any shade in RAL or NCS system upon request
Profiles	P0; P5; other edge profiles upon request
Fire reaction class	B-s1, d0

Maximum opening dimensions for hatches in CEWOOD panels

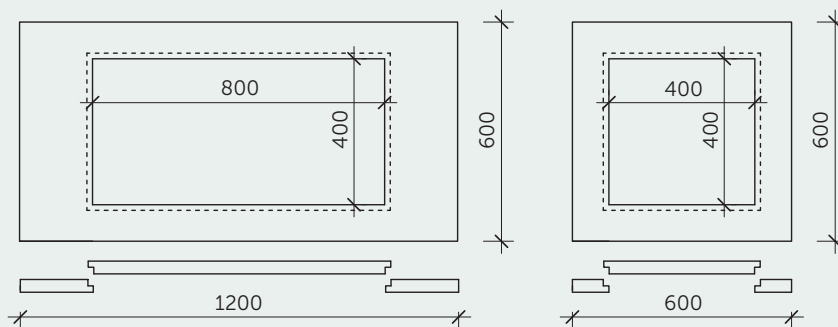

- ⓘ Inspection hatches can be integrated into both CEWOOD panels and Barcode panels and fixed with screws to a metal or wooden substructure, or into a T-profile grid. Panels with inspection hatches must be installed in accordance with the CEWOOD panel installation requirements.