

Inserting-bags made of combined materials
Bth-3L-05-315x245 R (T-Tap REV)

Product Description

Application – for food product storage. Dimensions, capacity, weight of the bags, and maximum allowed deviations from the specified parameters must correspond to the drawing and graphic representation.

Product name:
 Inserting-bags made of combined materials
 Bth-3L-05-315x245 R (T-Tap REV)

Inserting-bags application:
 liquid product

Additional inserting-bags processing: -

Fitment orientation: 6 o'clock

Manufacturer: TECHNOLOGIA JSC

Graphic presentation:

Volume, (l): 3

Size A, (mm): 315

Size B, (mm): 245

Size C, (mm): 50

Size D, (mm): 50

Size V, (mm): 15

Size F, (mm): -

Tolerance, (mm) ±5

Graphic Representation

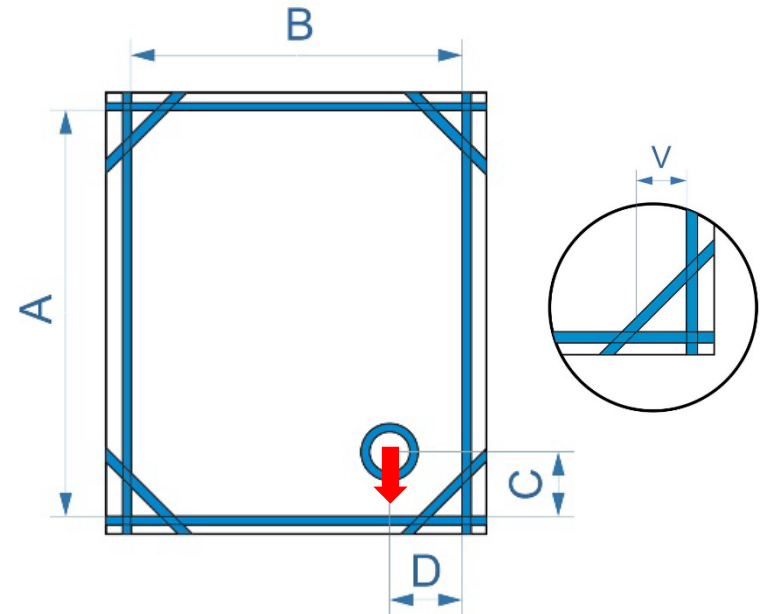

Marking

Marking applied onto each bag contains the following information: company logo, type of the bag, capacity, bags dimensions, batch number, production date and time, logo "food contact" and Mobius loop with a code of material.

Storage and transportation conditions

Empty inserting-bags should be kept in ventilated premises without foreign odour and direct sunlight, at a distance of more than 1 m from heating devices, at a temperature from -5 °C to +40 °C with relative air humidity of less than 80%

Barrier properties of the inserting bags

Level of oxygen penetration according to the specification - < 1,5 cm³/m²/day, the average statistical value - 0,85 cm³/m²/day (at a temperature of 25 ° C and a relative humidity of 65%).
 Lever of water vapor penetration level - < 4 g/m²/day (at a temperature of 38 ° C and a relative humidity of 90%).

Mechanical Characteristics

Data	Minimum value
Weld strength, (N/m)	333,3
Hermeticity, (Pa)	392
Weld, (mm)	4-8

Fitment

Type of fitment:	T-Tap REV
Material:	PP / PE / TPE
Color:	Natural / Red / White
Type of spout:	HST-Tap
Material:	PE
Color:	Natural

T-Tap REV



HST-Tap

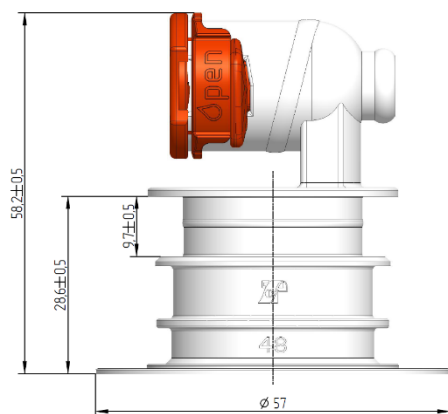

DIMENSIONS FOR REFERENCE,
INDICATED FOR ADJUSTMENT OF THE FILLING MACHINE

Materials



A External layer

Material:	EVOH
Color:	Transparent
Thickness:	70 mcm

B Internal layer

Material:	PE
Color:	Transparent
Thickness:	50 mcm

Filling Conditions

Product temperature from 4°C to 90°C.

Warranty Period

The guaranteed shelf-life of the inserting-bags is 12 months from the production date.

Approved

Customer

Full name: _____

Date: _____

Signature: _____

Manufacturer

Full name: _____

Date: _____

Signature: _____

Packing

The bags are packed in a plastic bag, fits in a corrugated cardboard box.
The boxes, sealed with tape, are stacked on wooden pallets.
Each pallet is wrapped in stretch film in height.

Size of cardboard box, (mm)	800 x 600 x 340
Number of bags per carton, (pcs)	600
Number of cardboard boxes per pallet, (pcs)	12
Number of bags per pallet, (pcs)	7 200
Pallet size, (mm)	1200 x 800 x 2 200

TECHNOLOGIA JSC

147-A, Peremohy ave., 40020, Sumy, Ukraine

Tel./fax: +38 0542 70 15 45

baginbox@technologia.com.ua

technologia.com.ua

