

Approval body for construction products
and types of construction

Bautechnisches Prüfamt

An institution established by the Federal and
Laender Governments



European Technical
Assessment

ETA-16/0889
of 22 May 2017

English translation prepared by DIBt - Original version in German language

General Part

Technical Assessment Body issuing the
European Technical Assessment:

Deutsches Institut für Bautechnik

Trade name of the construction product

SIHGA concrete screw BeziFix Anker

Product family
to which the construction product belongs

Concrete screw for use in concrete

Manufacturer

SIHGA® GmbH
Gewerbepark Kleinreith 4
4694 OHLSDORF
ÖSTERREICH

Manufacturing plant

Herstellwerk 1

This European Technical Assessment
contains

12 pages including 3 annexes which form an integral part
of this assessment

This European Technical Assessment is
issued in accordance with Regulation (EU)
No 305/2011, on the basis of

European Assessment Document (EAD)
330232-00-0601

The European Technical Assessment is issued by the Technical Assessment Body in its official language. Translations of this European Technical Assessment in other languages shall fully correspond to the original issued document and shall be identified as such.

Communication of this European Technical Assessment, including transmission by electronic means, shall be in full. However, partial reproduction may only be made with the written consent of the issuing Technical Assessment Body. Any partial reproduction shall be identified as such.

This European Technical Assessment may be withdrawn by the issuing Technical Assessment Body, in particular pursuant to information by the Commission in accordance with Article 25(3) of Regulation (EU) No 305/2011.

Specific Part

1 Technical description of the product

The SIGHA concrete screw BeziFix Anker is an anchor in size 7.5, 10.5 and 12 mm made of galvanised steel. The anchor is screwed into a predrilled cylindrical drill hole. The special thread of the anchor cuts an internal thread into the member while setting. The anchorage is characterised by mechanical interlock in the special thread.

The product description is given in Annex A.

2 Specification of the intended use in accordance with the applicable European Assessment Document

The performances given in Section 3 are only valid if the anchor is used in compliance with the specifications and conditions given in Annex B.

The verifications and assessment methods on which this European Technical Assessment is based lead to the assumption of a working life of the anchor of at least 50 years. The indications given on the working life cannot be interpreted as a guarantee given by the producer, but are to be regarded only as a means for choosing the right products in relation to the expected economically reasonable working life of the works.

3 Performance of the product and references to the methods used for its assessment

3.1 Mechanical resistance and stability (BWR 1)

Essential characteristic	Performance
Characteristic resistance under static and quasi-static loading	See Annex C 1
Displacements under tension and shear loads	See Annex C 2

3.2 Safety in case of fire (BWR 2)

Essential characteristic	Performance
Reaction to fire	Anchorage satisfy requirements for Class A1
Resistance to fire	No performance assessed

3.3 Safety in use (BWR 4)

The essential characteristics regarding Safety in use are included under the Basic Works Requirement Mechanical resistance and stability.

4 Assessment and verification of constancy of performance (AVCP) system applied, with reference to its legal base

In accordance with European Assessment Documents EAD No. 330232-00-0601 the applicable European legal act is: [96/582/EC].

The system to be applied is: 1

5 Technical details necessary for the implementation of the AVCP system, as provided for in the applicable European Assessment Document

Technical details necessary for the implementation of the AVCP system are laid down in the control plan deposited at Deutsches Institut für Bautechnik.

Issued in Berlin on 22 May 2017 by Deutsches Institut für Bautechnik

Andreas Kummerow
Head of Department

beglaubigt:
Baderschneider

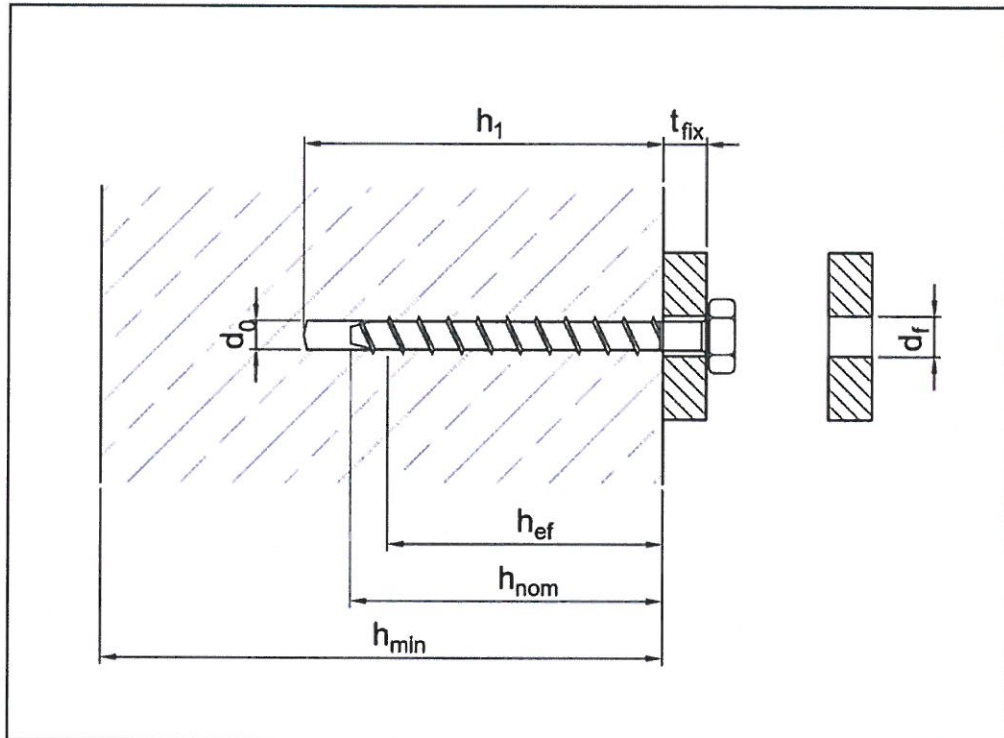

BeziFix Anker hexagon head and hexagon head with flange: sizes 7,5, 10,5 and 12,5

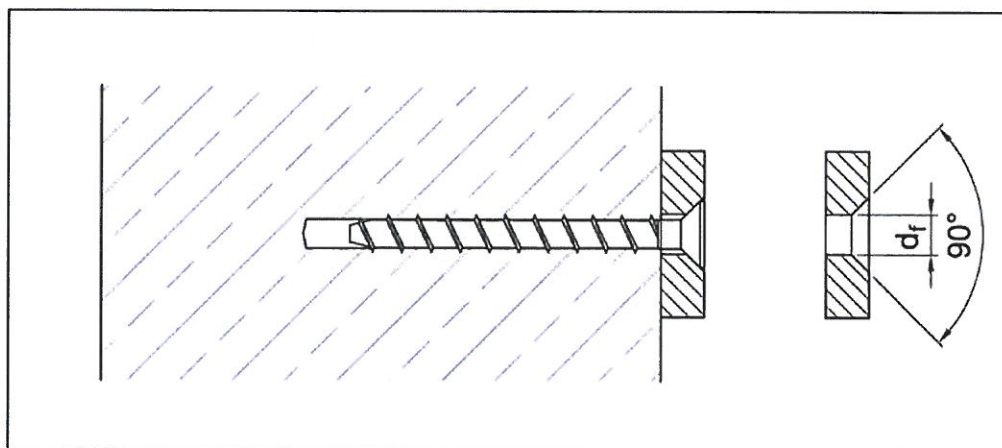

BeziFix Anker countersunk head: size 7,5

SIHGA concrete screw BeziFix Anker

Product description
Installed condition

Annex A 1

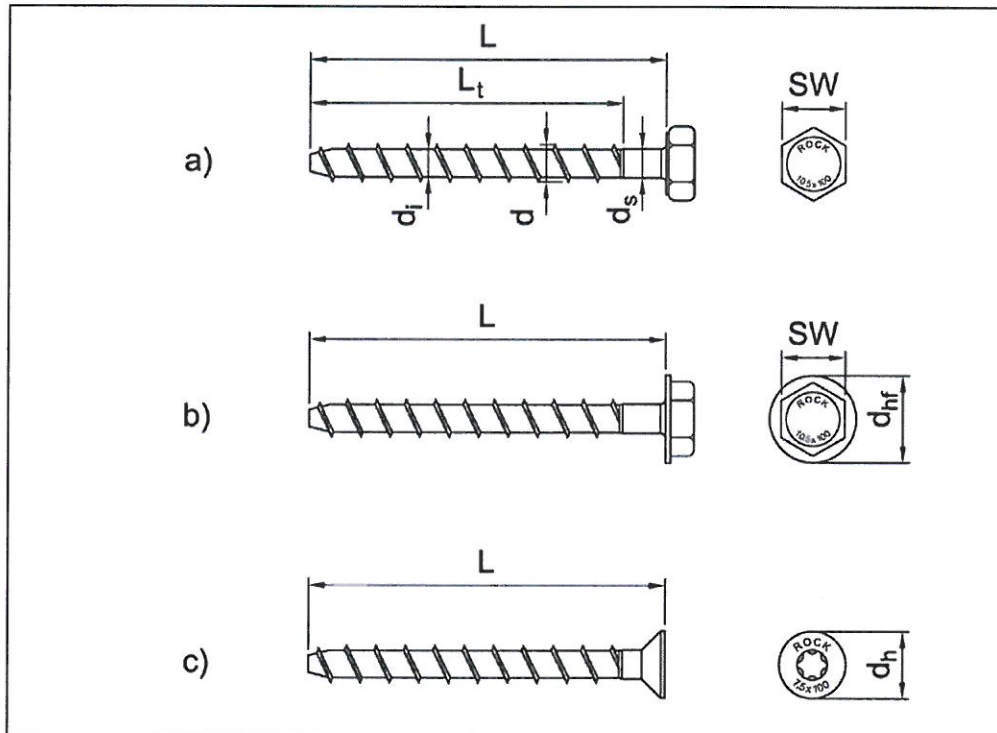

Screw types: a) BeziFix Anker hexagon head 7,5, 10,5 and 12,5.
b) BeziFix Anker hexagon head with flange 7,5, 10,5 and 12,5.
c) BeziFix Anker countersunk head 7,5.
Head marking: "Rock" and size x screw length.

Table A2: Dimensions and material

SIHGA concrete screw BeziFix Anker			Nominal size		
			Ø 7,5 mm	Ø 10,5 mm	Ø 12,5 mm
Outer thread diameter	d	[mm]	7,5	10,5	12,5
Inner thread diameter	d _i	[mm]	5,4	7,6	9,4
Shaft diameter	d _s	[mm]	5,85	7,90	9,85
Stressed section	A _t	[mm ²]	22,90	45,36	69,70
Wrench size	SW	[mm]	SW13	SW15	SW17
Flange diameter	d _{hf}	[mm]	16,5	17,5	22,0
Head diameter countersunk head	d _h	[mm]	14,0	n/a	n/a
Screw anchor length	L	[mm]	60 ≤ L ≤ 100	80 ≤ L ≤ 160	80 ≤ L ≤ 320
Thread length	L _t	[mm]	55	75	75 ^{a)} /95
Material	-	-	carbon steel, galvanized		
Characteristic yield strength	f _{y,k}	[N/mm ²]	900	900	900
Characteristic ultimate tensile strength	f _{u,k}	[N/mm ²]	1000	1000	1000

^{a)} L_t = 75 for L = 80. For all other screw anchor lengths L_t = 95.

SIHGA concrete screw BeziFix Anker

Product description
Material and screw types

Annex A 2

Specifications of the intended use

Anchorage subject to:

- Static and quasi-static loads: all sizes.

Base materials:

- Reinforced or unreinforced normal weight concrete according to EN 206-1:2000.
- Strength classes C20/25 to C50/60 according to EN 206-1:2000.
- Non-cracked and cracked concrete: all sizes.

Use conditions (Environmental conditions):

- Structures subject to dry internal conditions.

Design:

- Anchorages are designed under the responsibility of an engineer experienced in anchorages and concrete work.
- Verifiable calculation notes and drawings are prepared taking account of the loads to be anchored. The position of the anchor is indicated on the design drawings.
- Anchorages under static or quasi-static actions are designed in accordance with EN 1992-4:2017.
- The design of anchorages under shear load according to EN 1992-4:2017, Section 6.2.2 applies for all specified diameters d_f of clearance hole in the fixture in Annex B3, Table B3.1.

Installation:

- Hole drilling for all sizes by hammer drilling only.
- Anchor installation by using an impact screw driver with a maximum output T_{max} according to manufacturer specification of 250 Nm (BeziFix Anker 7,5) or 450 Nm (BeziFix Anker 10,5 and 12,5).
- Anchor installation carried out by appropriately qualified personnel and under the supervision of the person responsible for technical matters of the site.
- In case of aborted hole: new drilling at a minimum distance of twice the depth of the aborted hole. A smaller distance may be used if the aborted hole is filled with high strength mortar and if the aborted hole is not placed in the direction of the load application in case it is loaded laterally or by oblique tension.
- The anchor may be used only once.
- The fixture is fully pressed onto the surface of the concrete member without any intermediate layer.
- The head of the anchor is fully supported on the fixture and is not damaged.

SIHGA concrete screw BeziFix Anker

**Intended use
Specifications**

Annex B 1

Installation instructions

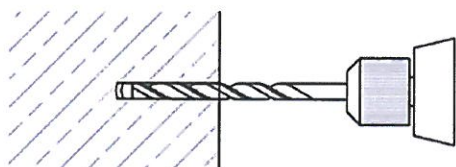

1. Drilling the hole by hammer drilling

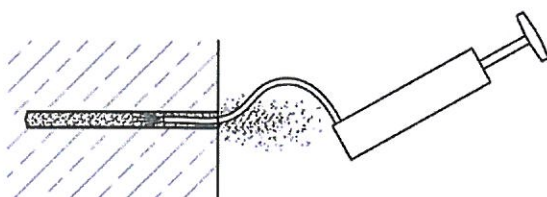

2. Cleaning the hole, e.g. by blowing

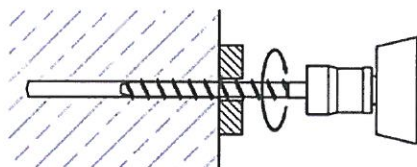

3. Installing the concrete screw through the fixture using an impact screw driver

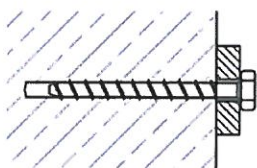

4. Fixture is fully pressed onto the surface of the concrete member without intermediate layer
Screw head is fully supported on the fixture and is not damaged

SIHGA concrete screw BeziFix Anker

Intended use
Installation instructions

Annex B 2

Installation parameters

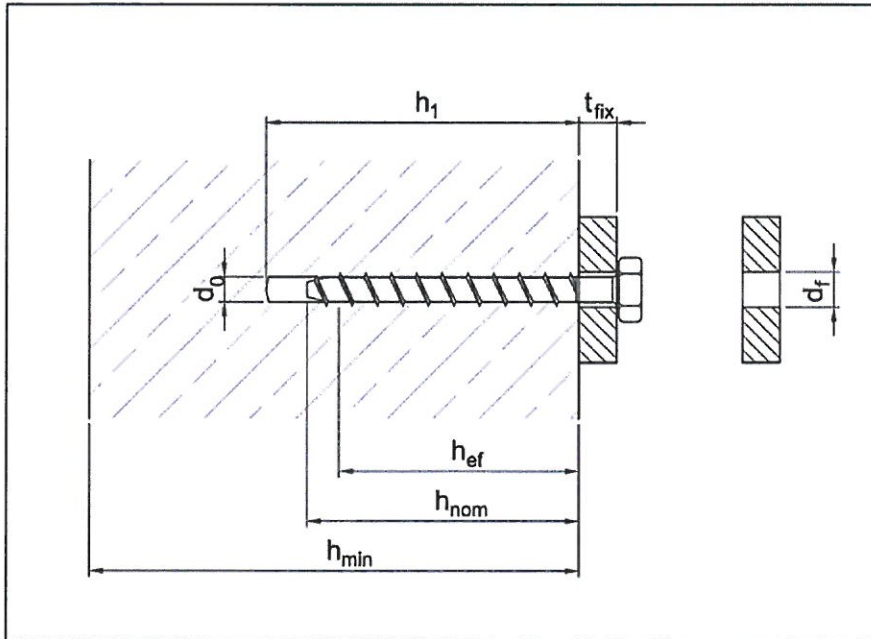

Table B3.1: Installation parameters

SIHGA concrete screw BeziFix Anker			Nominal size		
			Ø 7,5 mm	Ø 10,5 mm	Ø 12,5 mm
Nominal drill diameter	d_0	[mm]	6	9	10
Max. cutting diameter of the drill bit	$d_{cut,max}$	[mm]	6,40	9,45	12,45
Min. depth of drill hole	$h_1 \geq$	[mm]	70	90	110
Embedment depth	h_{nom}	[mm]	55	75	95
Effective anchorage depth	h_{ef}	[mm]	41	55	71
Diameter of clearance hole in the fixture	$d_f \leq$	[mm]	9,0	12,0	14,0
Wrench size of concrete screw	SW	[mm]	13	15	17
Drive countersunk head	TX	-	TX40	n/a	n/a
Recommended installation tool: impact screw driver max. output according to manufacturer specification	T_{max}	Nm	250	450	450

Table B3.2: Minimum thickness of concrete member, minimum spacings and edge distances

SIHGA concrete screw BeziFix Anker			Nominal size			
			Ø 7,5 mm	Ø 10,5 mm	Ø 12,5 mm	
Minimum thickness of concrete member	h_{min}	[mm]	100	160	200	
cracked and non-cracked concrete	Minimum spacing	s_{min}	[mm]	40	55	65
	Minimum edge distance	c_{min}	[mm]	40	55	65

SIHGA concrete screw BeziFix Anker

Intended use

Installation parameters, minimum thickness of concrete member, minimum spacings and edge distances

Annex B 3

Installation parameters

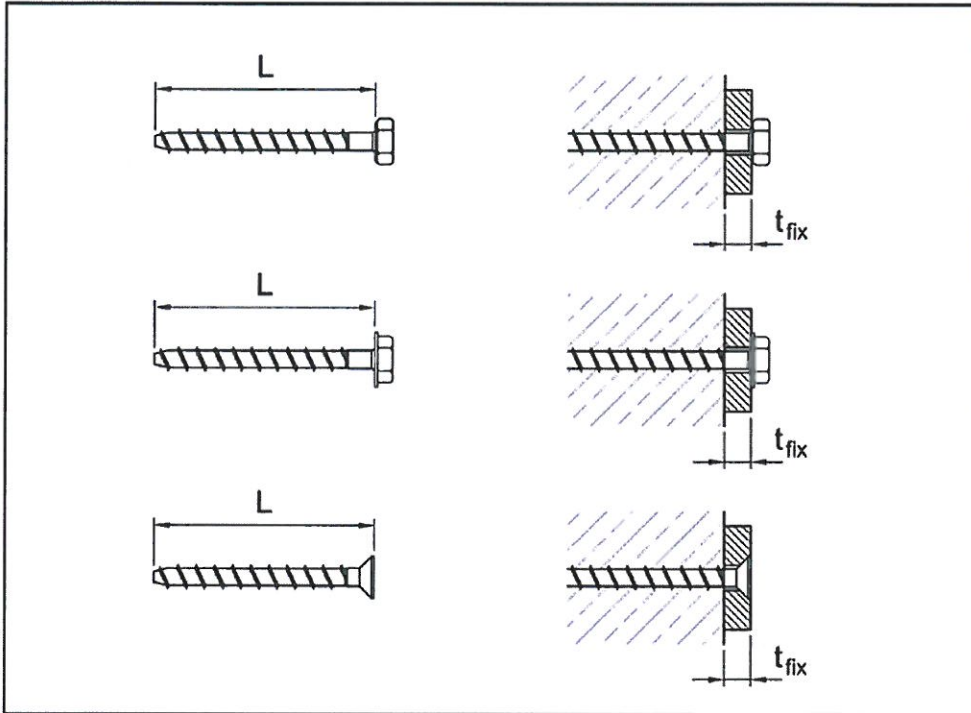

Table B4: Screw length and maximum thickness of fixture $t_{fix,max}$

SIHGA concrete screw BeziFix Anker	Nominal size		
	Ø 7,5 mm	Ø 10,5 mm	Ø 12,5 mm
Screw length L [mm]	Max. thickness of fixture $t_{fix,max}$ [mm]		
60	5	-	-
80	25	5	5
100	45	25	5
120	-	45	25
140	-	65	45
160	-	85	65
180	-	-	85
200	-	-	105
240	-	-	145
280	-	-	185
300	-	-	205

SIHGA concrete screw BeziFix Anker

Intended use
Installation parameters

Annex B 4

Table C1: Characteristic values for static and quasi-static loading

SIHGA concrete screw BeziFix Anker			Nominal size		
			Ø 7,5 mm	Ø 10,5 mm	Ø 12,5 mm
Steel failure under tensile and shear loading					
Characteristic resistance	$N_{Rk,s}$	[kN]	23	45	69
Partial safety factor	$\gamma_{Ms,N}$	-	1,4		
Characteristic resistance	$V_{Rk,s}$	[kN]	7	13	34
Ductility factor	k_7	-	0,8		
Partial safety factor	$\gamma_{Ms,V}$	-	1,5		
Characteristic resistance	$M^0_{Rk,s}$	[Nm]	19	51	98
Partial safety factor	$\gamma_{Ms,M}$	-	1,5		
Pull-out failure in concrete					
Characteristic resistance in cracked concrete C20/25	$N_{Rk,p}$	[kN]	3	3	12
Characteristic resistance in non-cracked concrete C20/25	$N_{Rk,p}$	[kN]	6	6	24
Increasing factor for concrete	C30/37	ψ_c	-	1	1,12
	C40/50			1	1,21
	C50/60			1	1,35
Concrete cone and splitting failure					
Effective anchorage depth	h_{ef}	[mm]	41	55	71
Factor k_1	Cracked	$k_{cr,N}$	-	7,7	
	Non-cracked	$k_{ucr,N}$	-	11,0	
Concrete cone failure	Edge distance	$c_{cr,N}$	[mm]	$1,5 \times h_{ef}$	
	Spacing	$s_{cr,N}$	[mm]	$3 \times h_{ef}$	
Splitting failure	Edge distance	$c_{cr,sp}$	[mm]	100	140
	Spacing	$s_{cr,sp}$	[mm]	200	280
Installation safety factor	γ_{inst}	-	1,4	1,2	1,2
Concrete pry-out failure					
Factor	k_8	-	1,0	1,0	2,0
Concrete edge failure					
Effective length of anchor	$l_f = h_{ef}$	[mm]	41	55	71
Effective diameter of anchor	d_{nom}	[mm]	6	9	10

SIHGA concrete screw BeziFix Anker

Performances

Characteristic values for static and quasi-static loading

Annex C 1

Table C2.1: Displacement under tensile loading

SIHGA concrete screw BeziFix Anker				Nominal size		
				Ø 7,5 mm	Ø 10,5 mm	Ø 12,5 mm
Cracked concrete C20/25 to C50/60	Tension load	N	[kN]	1,43	1,43	5,71
	Displacement	δ_{N0}	[mm]	0,23	0,55	1,00
		$\delta_{N\infty}$	[mm]	0,92	0,47	0,45
Non-cracked concrete C20/25 to C50/60	Tension load	N	[kN]	2,86	2,86	11,90
	Displacement	δ_{N0}	[mm]	0,42	0,39	1,44
		$\delta_{N\infty}$	[mm]	0,44	0,75	0,82

Table C2.2: Displacement under shear loading

SIHGA concrete screw BeziFix Anker				Nominal size		
				Ø 7,5 mm	Ø 10,5 mm	Ø 12,5 mm
Cracked and non- cracked concrete C20/25 to C50/60	Shear load	V	[kN]	2,86	5,71	14,29
	Displacement	δ_{V0}	[mm]	1,26	1,90	2,57
		$\delta_{V\infty}$	[mm]	1,89	2,85	3,86

SIHGA concrete screw BeziFix Anker

Performances
Displacements

Annex C 2