

TECHNICAL DATA E-PRO TRANSPORT TROLLEYS

Refrigerated transport trolley

The E-Pro transport trolley system offers solutions for the transport and short-term storage of foods before distribution or regeneration. The system includes refrigerated, heated and neutral models of different sizes, which are compatible with Gastronorm food containers. The materials and technical and hygienic features of the transport trolleys are designed to meet the highest requirements of professional kitchens.



GENERAL

- Products are designed for the short-term storage and transporting of cold food
- Large 150mm rubber-coated wheels guarantee good mobility
- The plastic impact shield around the unit protects it from dents
- The watertight interior has bevelled and easy-to-clean inside corners
- Maintains food temperature cold for a long time also without power supply and with the refrigerating machine switched off

PERFORMANCE

- The technical features of products are designed to meet the requirements of cold storage and transport in +30°C ambient temperature. The capacity is verified by laboratory experiments
- The thermostat control includes a digital temperature display
- The temperature can be set between +2...+15°C
- The ventilated refrigeration guarantees even temperature distribution

TECHNICAL FEATURES

- Door opening angle 270°
- The units have 32mm thick walls, insulating material polyurethane
- Fitted with a durable 2m spiral cable
- Removable and water washable condensating air filter
- The locking latch with chain and cotter pin keeps the door closed during transport
- The refrigerating machine provides efficient refrigeration
- CFC and HCFC free
- The refrigerant is R404
- All E-Pro units are CE marked



Refrigerated transport trolley, TTC serie

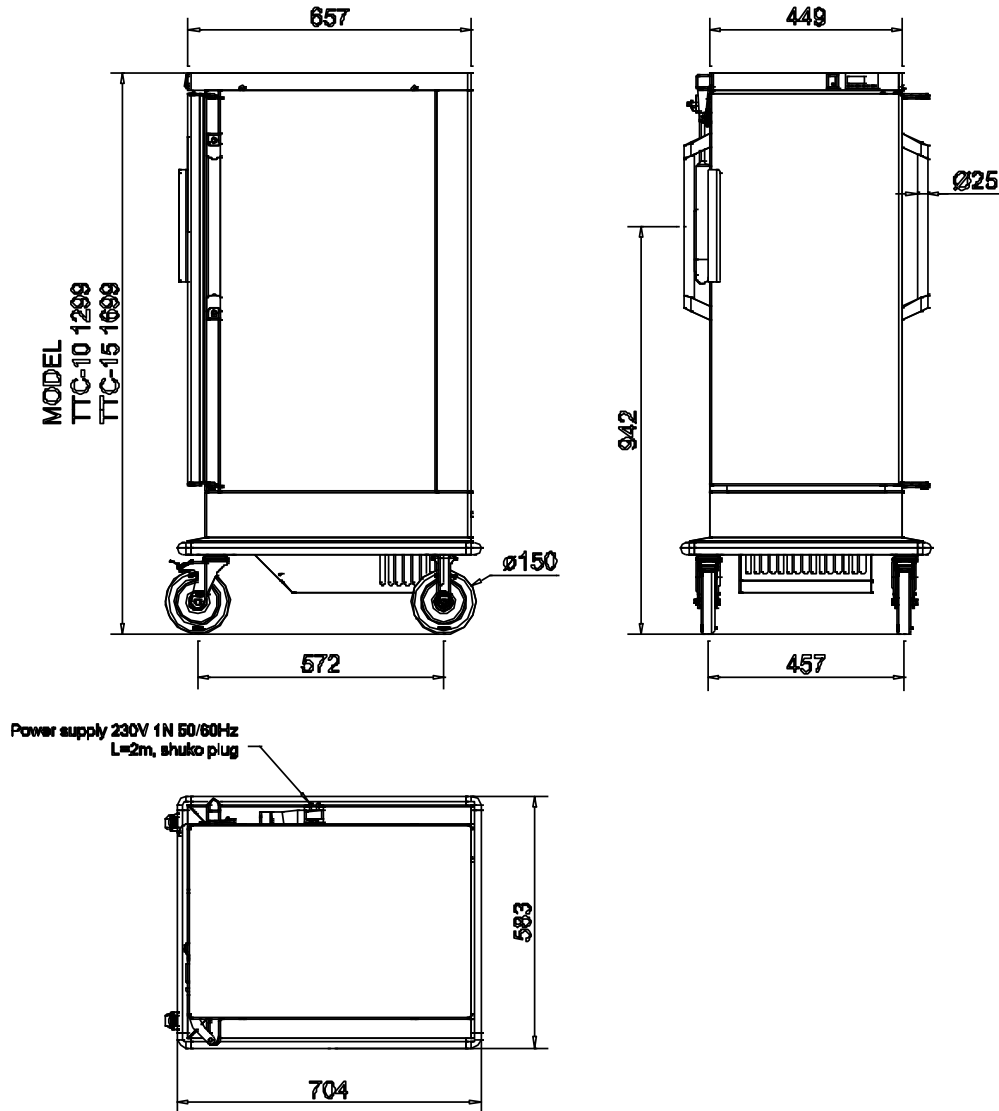

TECHNICAL DATA		
Model	TTC-10	TTC-15
External dimensions w x d x h mm	583x704x1299	583x704x1699
Temperature range °C	+2...+15	+2...+15
Guide bars no.	10	15
Guide bar distance mm	80	80
Capacity for GN 1/1 65 containers no.	10	15
Wheels	Ø150mm, 2 fixed, 2 rotating wheels with brakes	Ø150mm, 2 fixed, 2 rotating wheels with brakes
Electrical connection V, Hz	230 1N 50/60	230 1N 50/60
Connected load kW	0,42	0,42
Enclosure class	IP44	IP44
Type of refrigerant, g	R404, 190	R404, 195
Net weight kg	72	78
Dimensions mm	0,8	1,1
Unit dimensions mm		
width	600	600
depth	720	720
height	1500	1900

Due to continuous product development we reserve the right to technical changes without notice.

