

TECHNICAL DATA E-PRO COLD UNITS

Refrigerated drawers and cabinets for drinks



The E-Pro range of cold units includes various types of refrigerated units and worktops. Thanks to the flexible modular construction, they are easy to combine to create a customised food service system that best suits personal requirements. All units are made of stainless steel and comply with the hygiene standards for professional kitchens.



GENERAL

- Products are designed for the storage of cold beverages
- All surfaces are made of stainless steel
- Ø63.5mm adjustable feet, with a height adjustment range of -40/+20mm
- GN- and bottle basket sized cupboards and drawers
- Removable slide rails and PVC plastic magnetic gaskets
- The refrigerated wells have hygienic rounded corners
- Central locking with masterkeying option

PERFORMANCE

- The technical features of products are designed to meet the requirements of cold storage in +30 °C ambient temperature. The capacity is verified by laboratory experiments
- The temperature can be adjusted between +5 and +15°C
- The thermostat control includes a digital temperature display
- The ventilated refrigeration module guarantees even temperature distribution
- Two refrigeration machine options

TECHNICAL FEATURES

- The units have 42mm thick walls, insulating material polyurethane
- CFC and HCFC free
- Refrigerant is R134a
- The refrigeration module is removable without tools and comes with automatic defrost and evaporation of defrost water
- The refrigeration module features an automatic alarm of air-intake filters dirtiness option
- HACCP option available for all models
- All E-Pro cold units are CE marked



Refrigerated drawers and cabinets for drinks, CD

serie **EP E-Pro**

- Temperature range: **+5...+15°C** (maximum ambient temperature of +30 °C in cold storage)
- Refrigerator modules: **C1, C2, CH1**
- Unit modules: **1, 2**

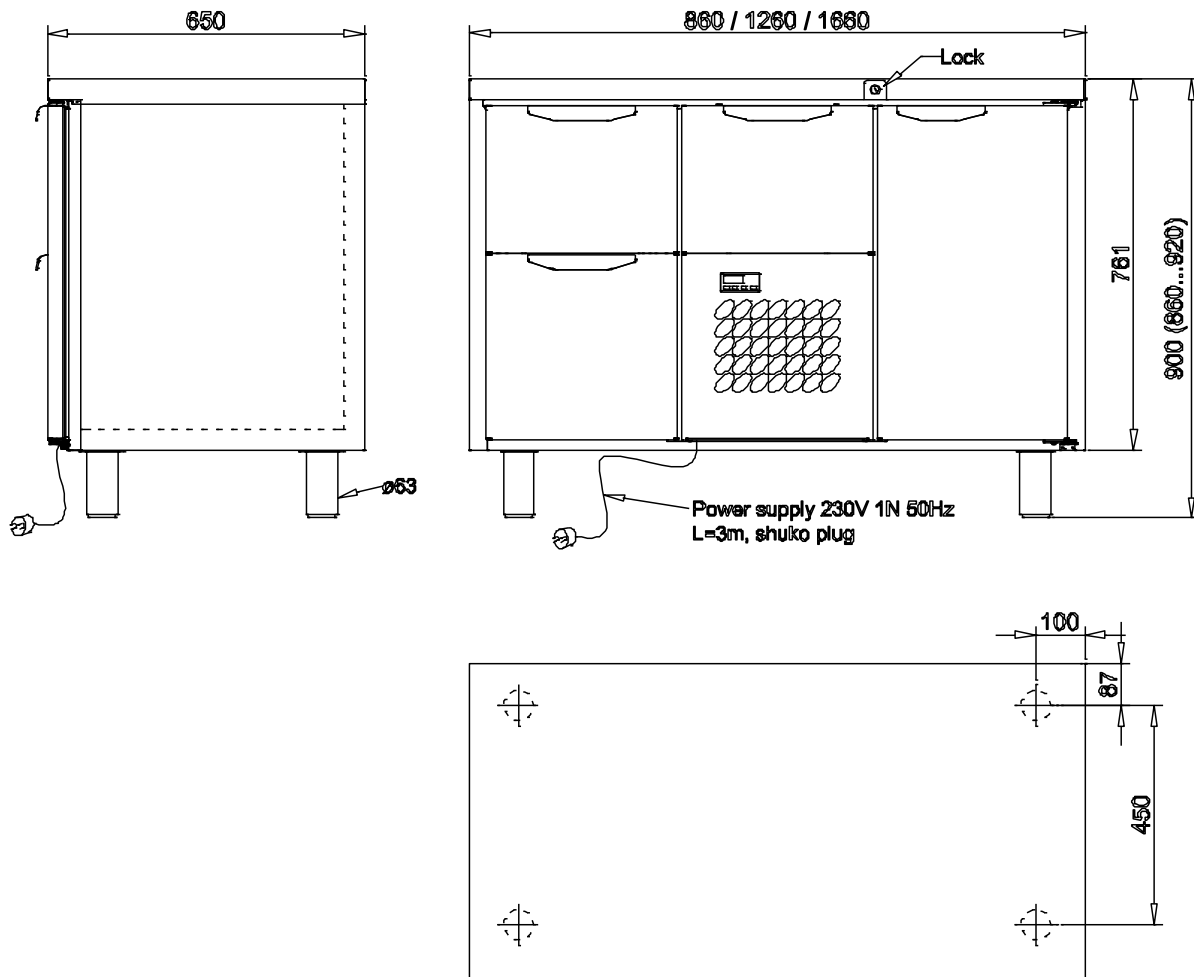

TECHNICAL DATA						
Model	CD-2-C1	CD-2-C2	CD-2-C1-2	CD-2-C2-2	CD-2-C1-2-2	CD-2-CH1-2-2
External dimensions w x d x h mm	860x650x900	860x650x900	1260x650x900	1260x650x900	1660x650x900	1660x650x900
Temperature range °C	+5...+15	+5...+15	+5...+15	+5...+15	+5...+15	+5...+15
Internal volume dm ³	242	242	392	392	542	542
Type of refrigerant g	R134a, 300	R134a, 300	R134a, 300	R134a, 300	R134a, 300	R134a, 300
Electrical connection V, Hz	230 1N, 50	230 1N, 50	230 1N, 50	230 1N, 50	230 1N, 50	230 1N, 50
Connected load W	350	350	350	350	350	750
Enclosure class	IP44	IP44	IP44	IP44	IP44	IP44
Net weight kg	94	94	123	123	153	161
HACCP option	included	included	included	included	included	included
Unit volume m ³	0,7	0,7	1,0	1,0	1,3	1,3
Unit dimensions mm						
height	1050	1050	1050	1050	1050	1050
depth	750	750	750	750	750	750
width	900	900	1300	1300	1700	1700

Due to continuous product development we reserve the right to technical changes without notice.



Refrigerated cabinets for drinks, CDB2 serie



- Temperature range: **+5...+15°C** (maximum ambient temperature of +30 °C in cold storage)
- Refrigerator modules 1260mm wide model: **C1, CH1**
- Refrigerator modules 1660mm wide model: **CH1**
- Unit modules: **1**

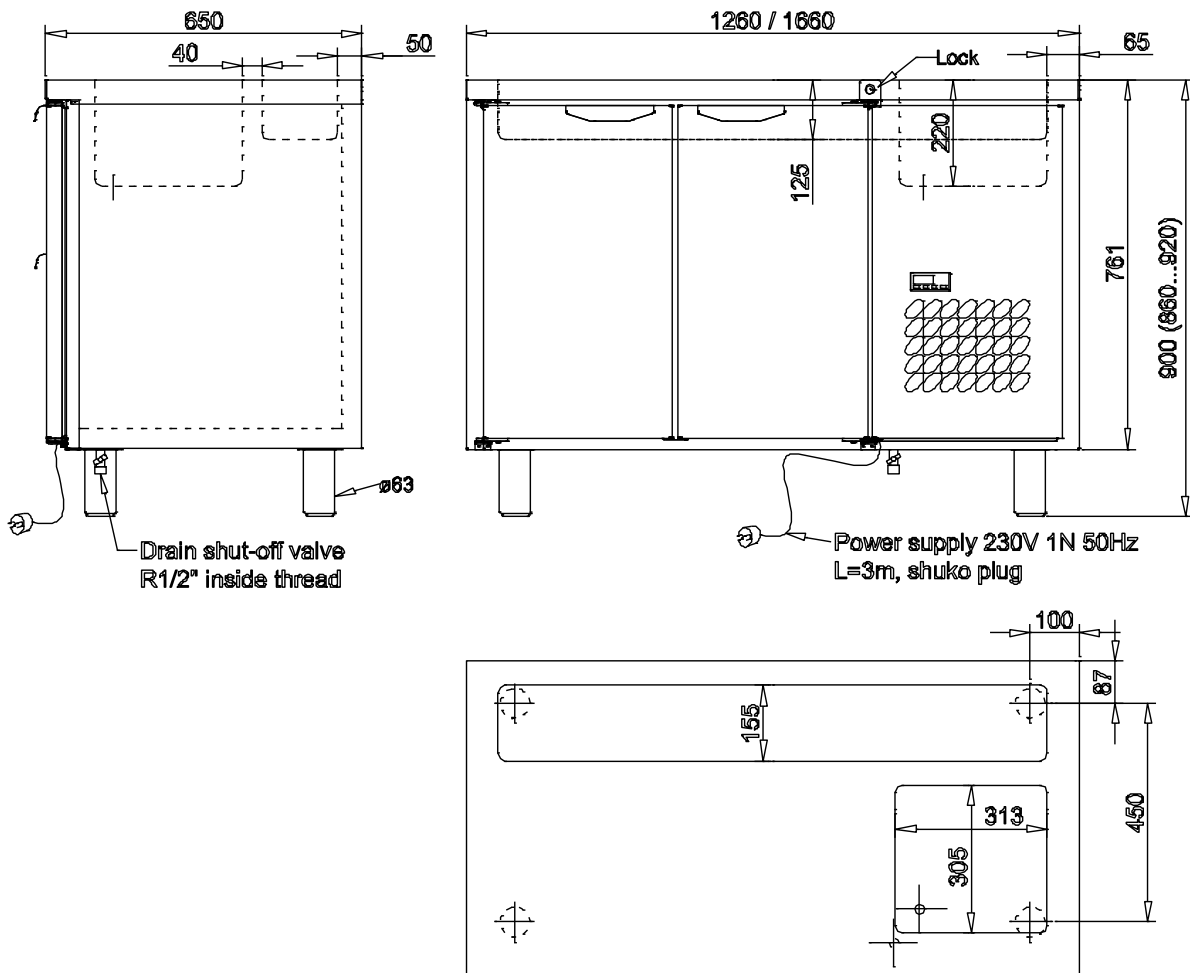

TECHNICAL DATA		
Model	CDB2-1-1-C1	CDB2-1-1-1-CH1
External dimensions w x d x h mm	1260x650x900	1660x650x900
Temperature range °C	+5...+15	+5...+15
Net volume dm ³	392	542
Type of refrigerant g	R134a, 300	R134a, 300
Electrical connection V, Hz	230 1N, 50	230 1N, 50
Connected load W	350	750
Enclosure class	IP44	IP44
Net weight kg	115	153
HACCP option	included	included
Unit volume m ³	1,0	1,3
Unit dimensions mm		
height	1050	1050
depth	750	750
width	1300	1700

Due to continuous product development we reserve the right to technical changes without notice.





Refrigerator modules

- C1** Refrigerator module 350W without drawer, temperature range +5...+15°C
- C2** Refrigerator module 350W with a drawer sized for a bottle basket, temperature range +5...+15°C
- CH1** Refrigerator module 750W without drawer, temperature range +5...+15°C

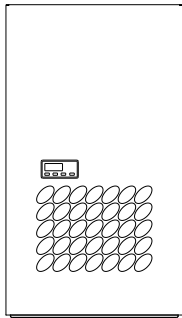

C1

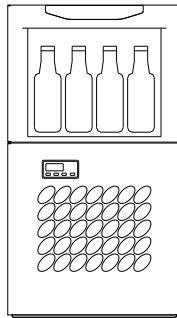

C2

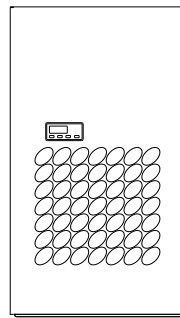

CH1

Unit modules

- 1** Cupboard with a closed door, two removable shelves and seven pairs of removable shelf brackets
- 2** 2 drawers for bottle baskets. S/s bottle boxes are included.

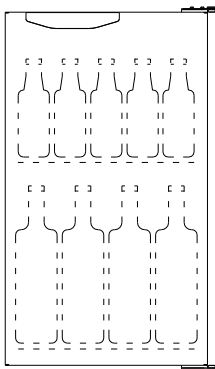

1

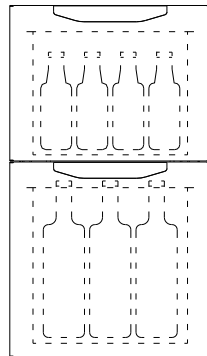

2

