

TECHNICAL DATA E-PRO DROP-IN UNITS

Drop-in refrigerated display

The E-Pro drop-in unit range offers all the equipment needed for a complete and effective self-service line. The top quality units, sized to take GN containers, are compact in size and come equipped with a separate digital control panel.



GENERAL

- E-Pro's drop-in refrigerated display units are designed for food service use and maintaining cold food temperature
- The hygienic wells come with rounded corners, and the exposed surfaces have a seamless finish
- The separate control panel has a connector and is easy to install
- The display units include fluorescent lamps as a standard feature

PERFORMANCE

- The digital control panel features an on/off switch and a temperature display
- The temperature in the well can be adjusted between +2 and +15°C, so that the temperature in the display case remains between +5 and +18°C
- As a standard feature, the package contains divider bars for GN 1/1 containers
- The refrigerated display well size is compatible with GN 1/1 containers
- The ventilated refrigeration guarantees even temperature distribution

TECHNICAL FEATURES

- The wells are lined with 30mm polyurethane insulation
- The units are fitted with a 3m and the control panel with a 1.5m power cord
- The material of the display unit is acrylic plastic for easy maintenance, and the top is made of stainless steel
- CFC and HCFC free
- Refrigerant R404a
- HACCP connection is optionally available
- All E-Pro drop-in units are CE marked



Drop-in refrigerated display

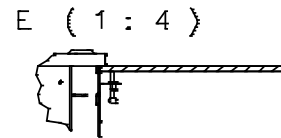
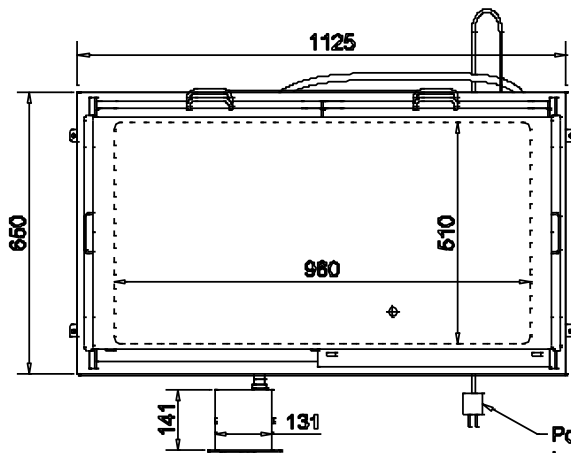
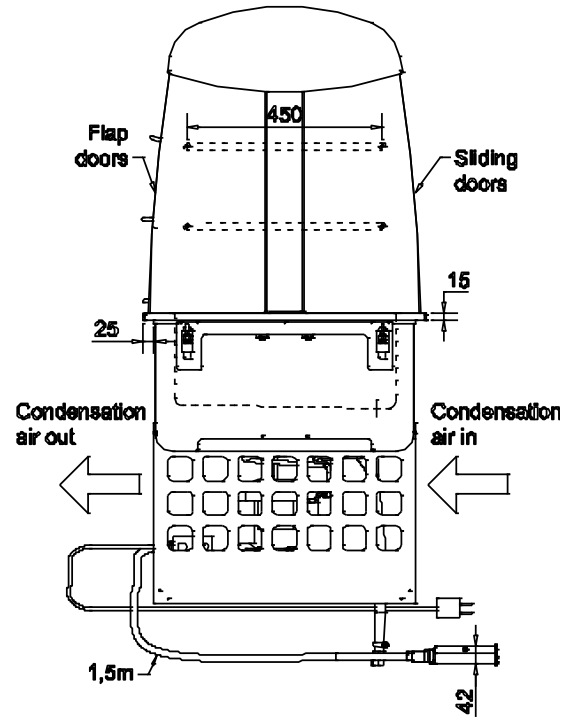
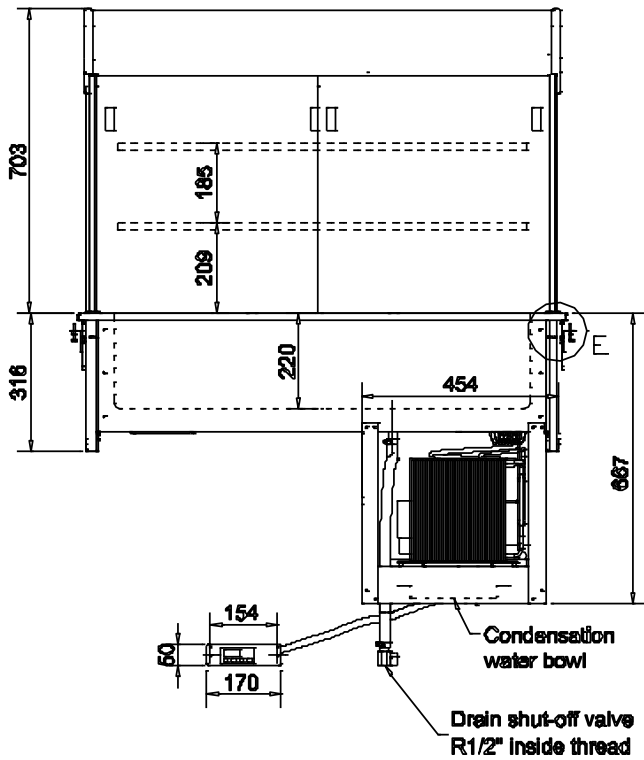

MODEL D-I 11 D CUT-OUT ON TABLE TOP mm 1110 x 634

Power supply 230V 1N 50/60Hz L=3m, shuko plug

TECHNICAL DATA	
Model	D-I 11 D
External dimensions w x d x h	1125x650x1370
Temperature range well °C (display case)	+2...+15 (+5...+18)
Electrical connection V, Hz	230 1N, 50/60
Connected load kW	0,9
Enclosure class	IP44
Type of refrigerant g	R404a, 300
HACCP option	included
Net weight kg	79
Unit volume m ³	1,0
Unit dimensions mm	
height	1500
depth	800
width	1250

Due to continuous product development we reserve the right to technical changes without notice.

