

RAAMIL



KUDUMINE



PÕLEMINE



Tiia Artla

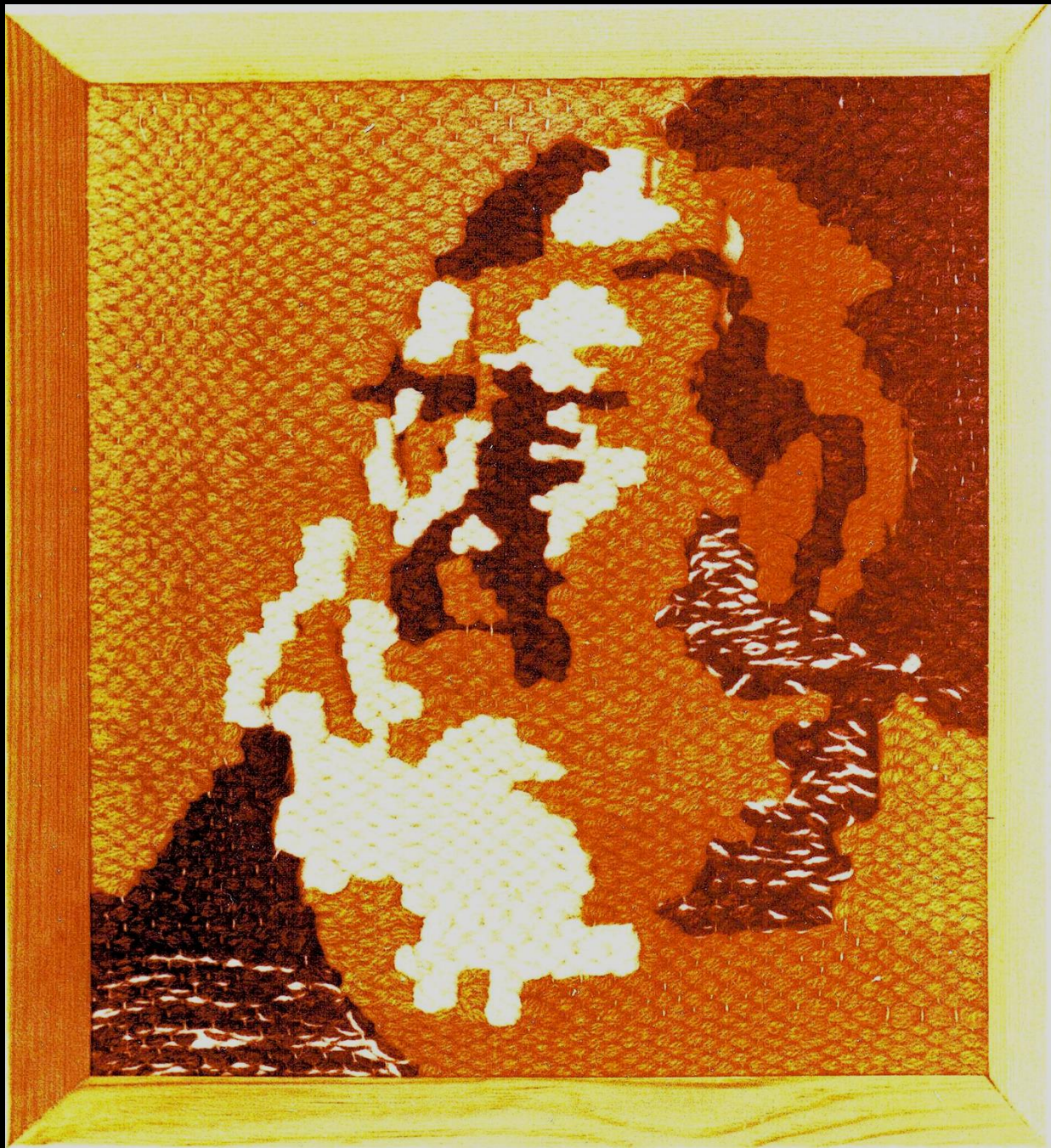

Tiia

Artla

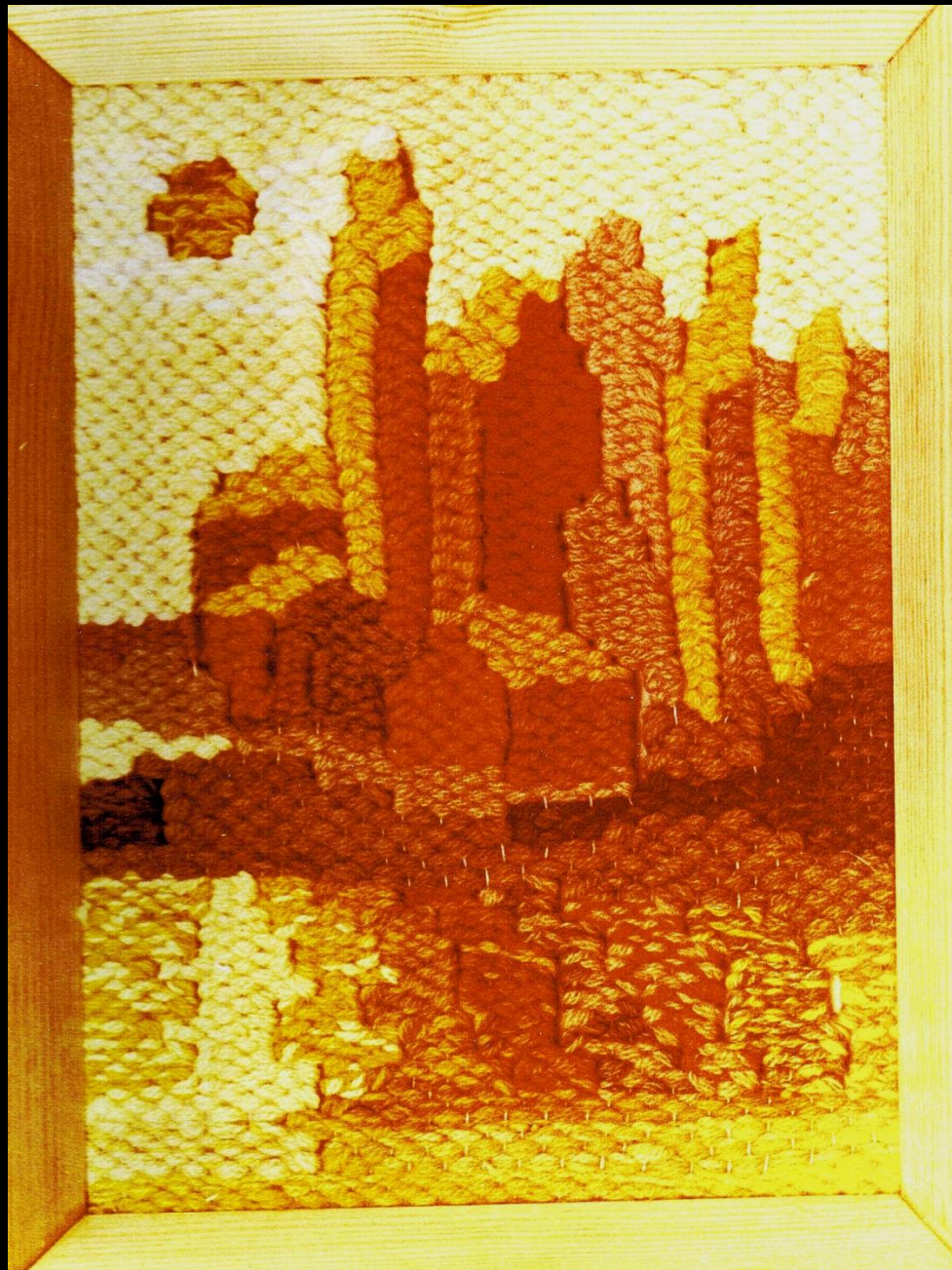

Tiia

Artla









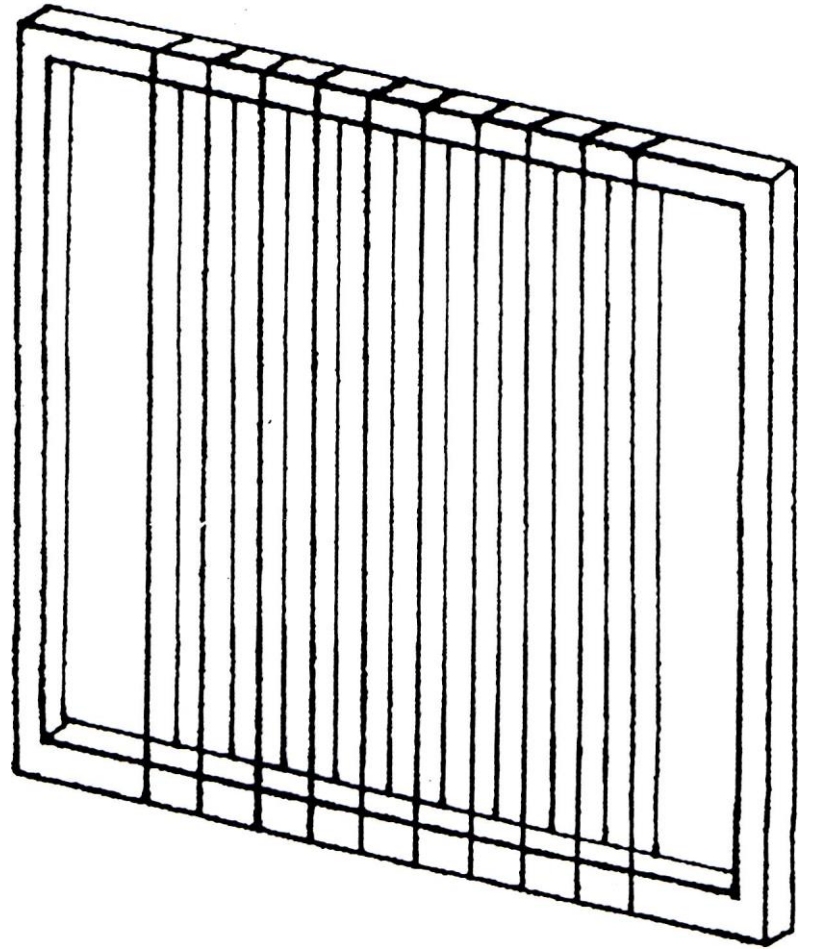
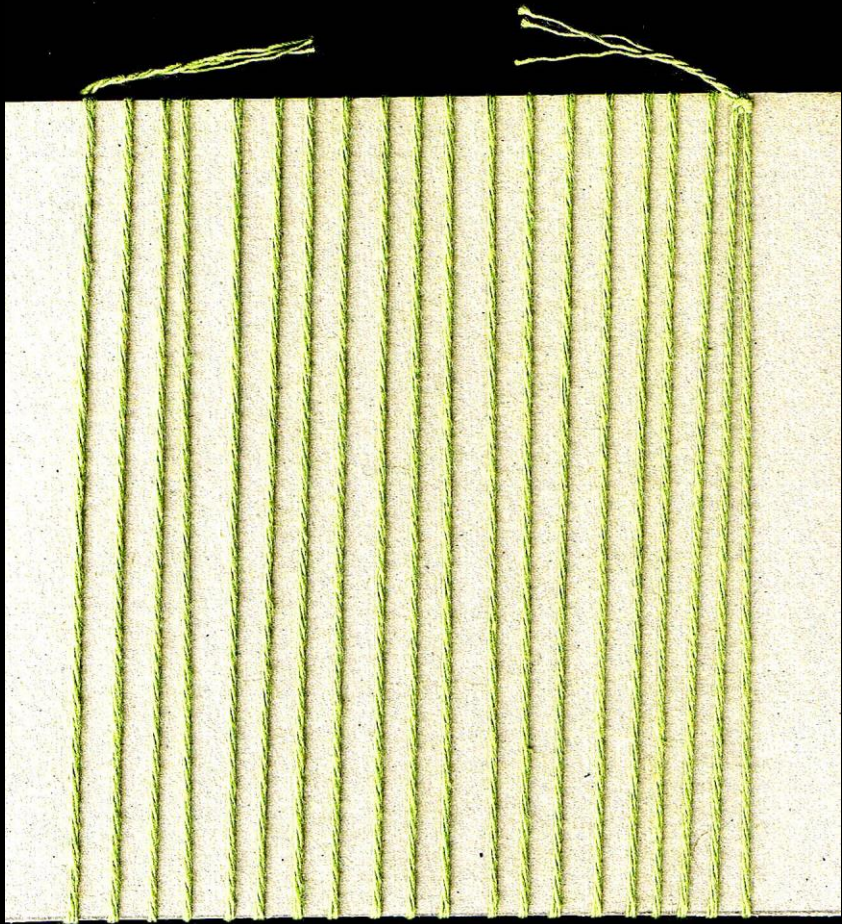

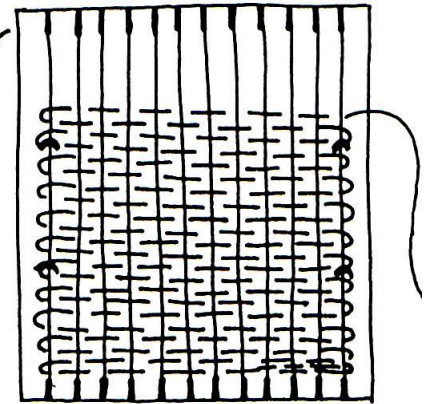
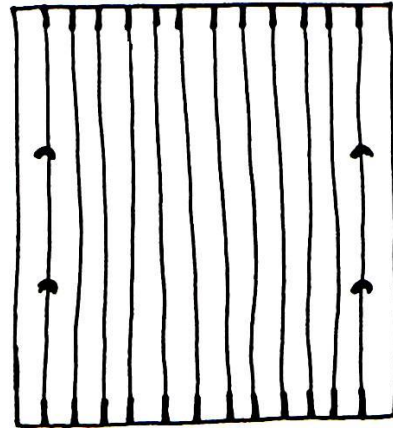
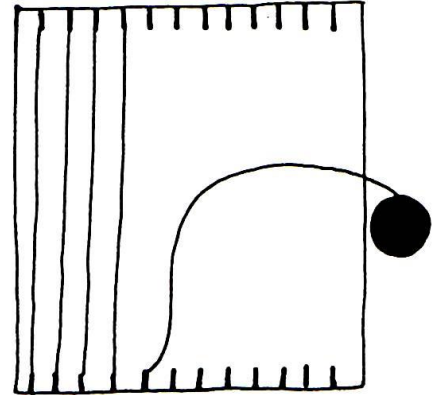
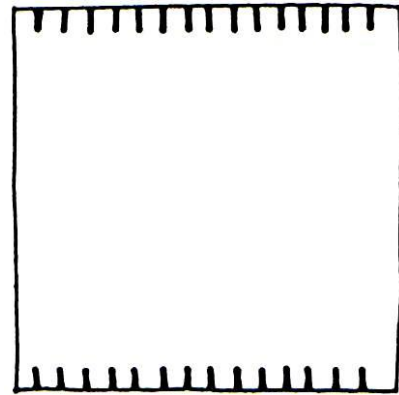
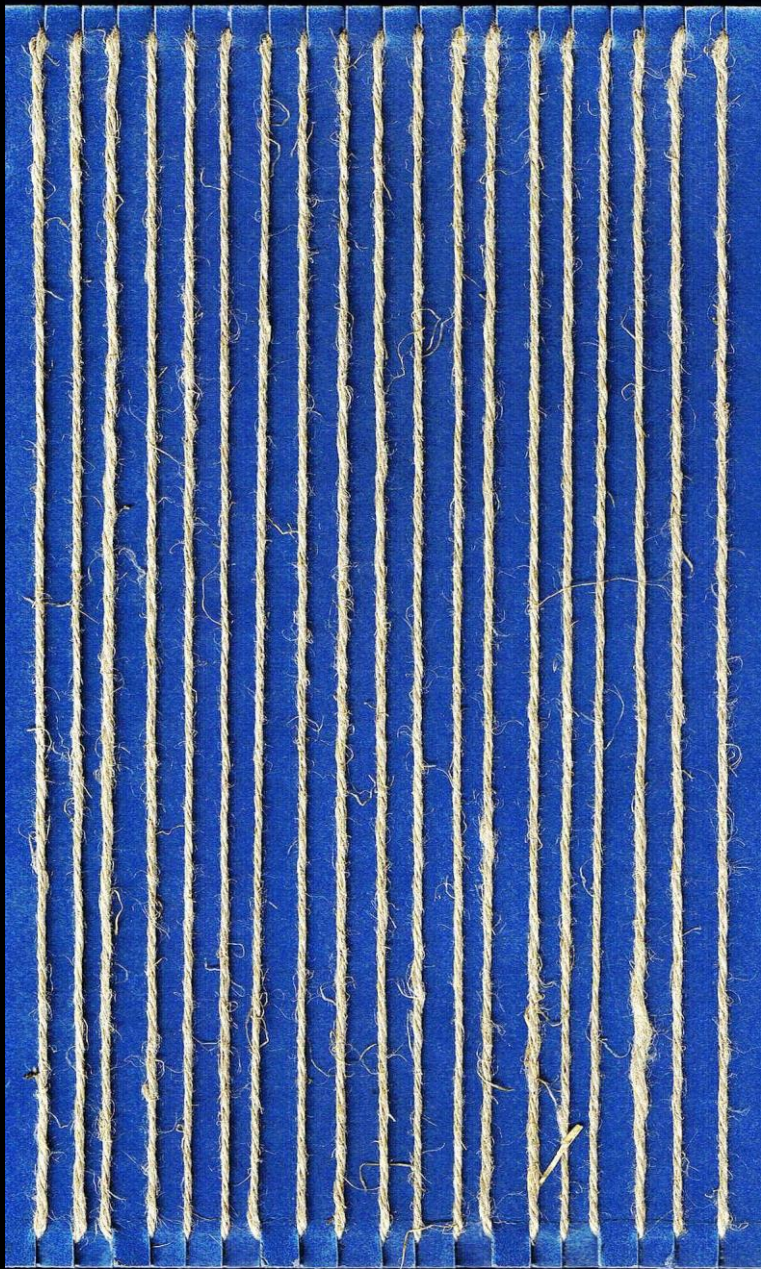

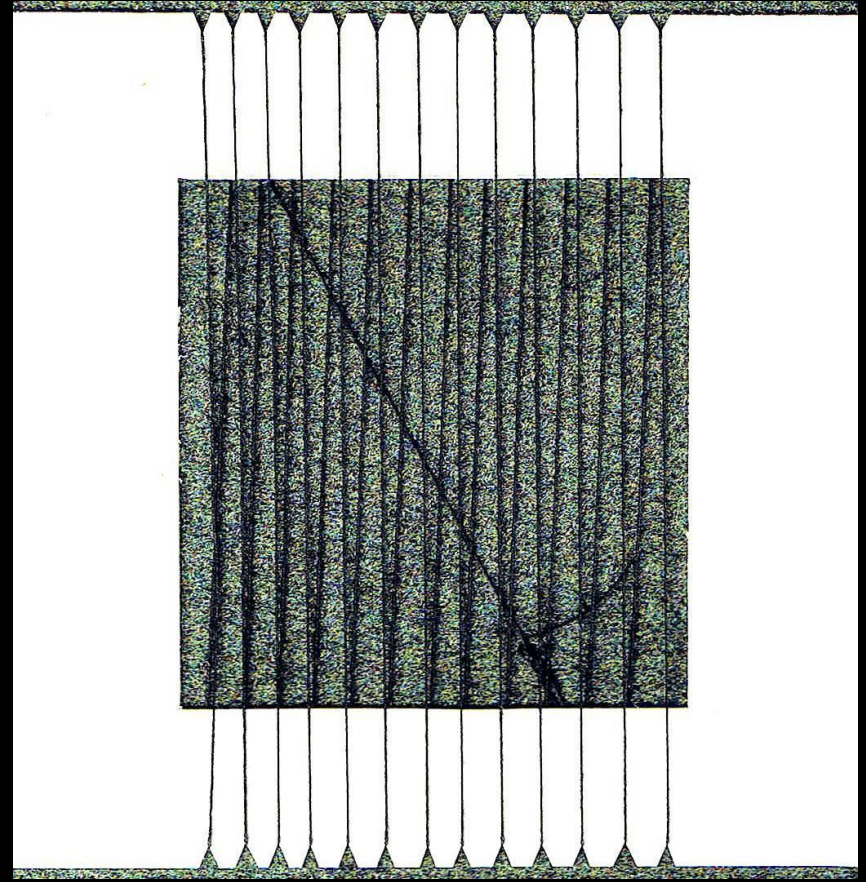
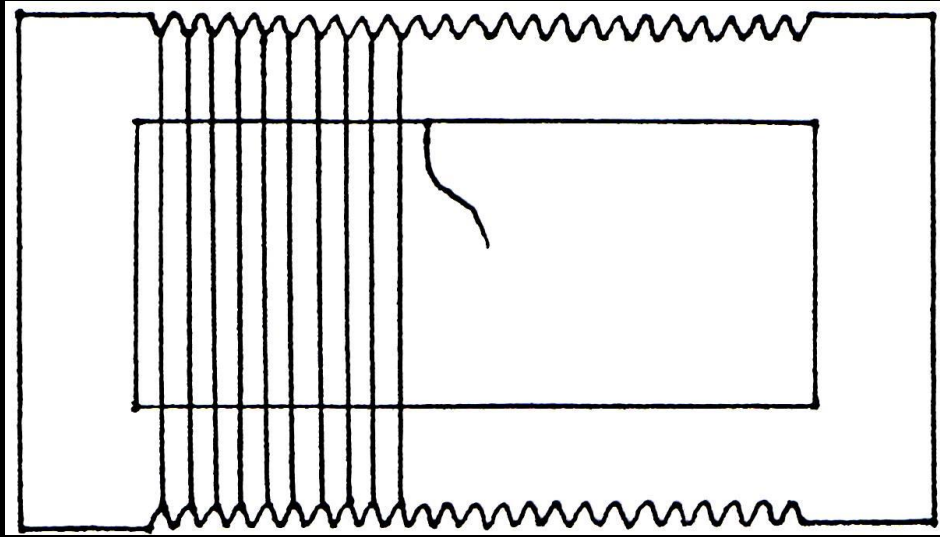

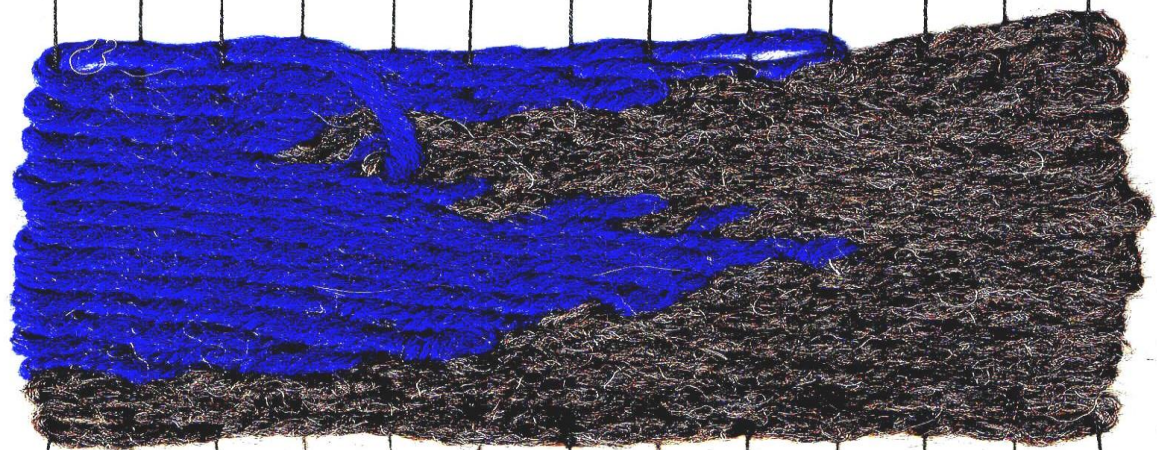

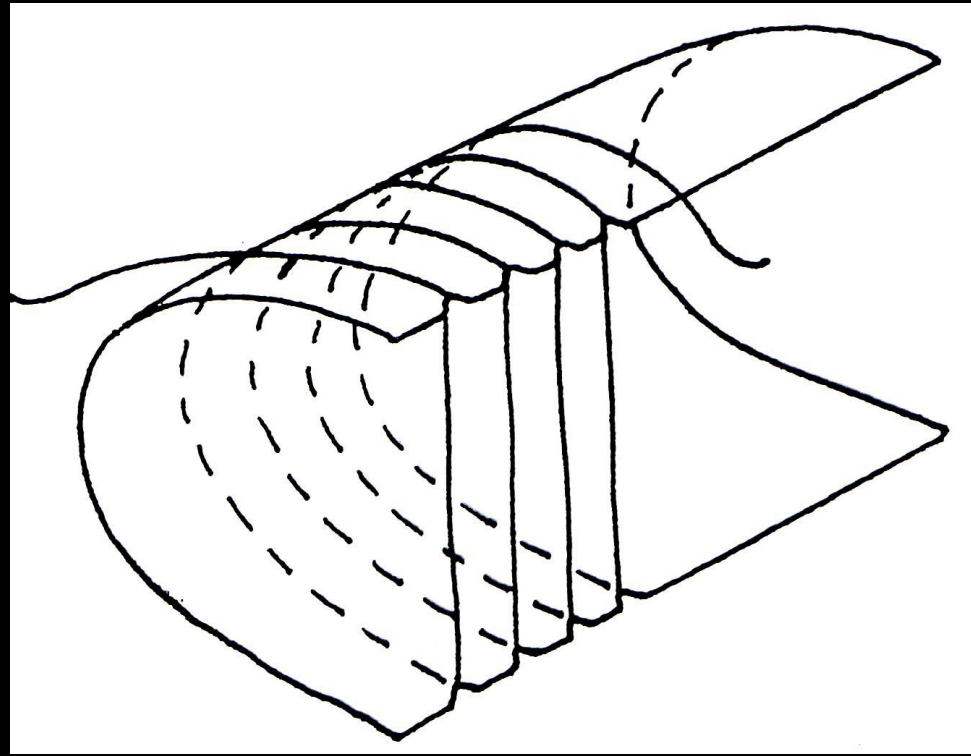
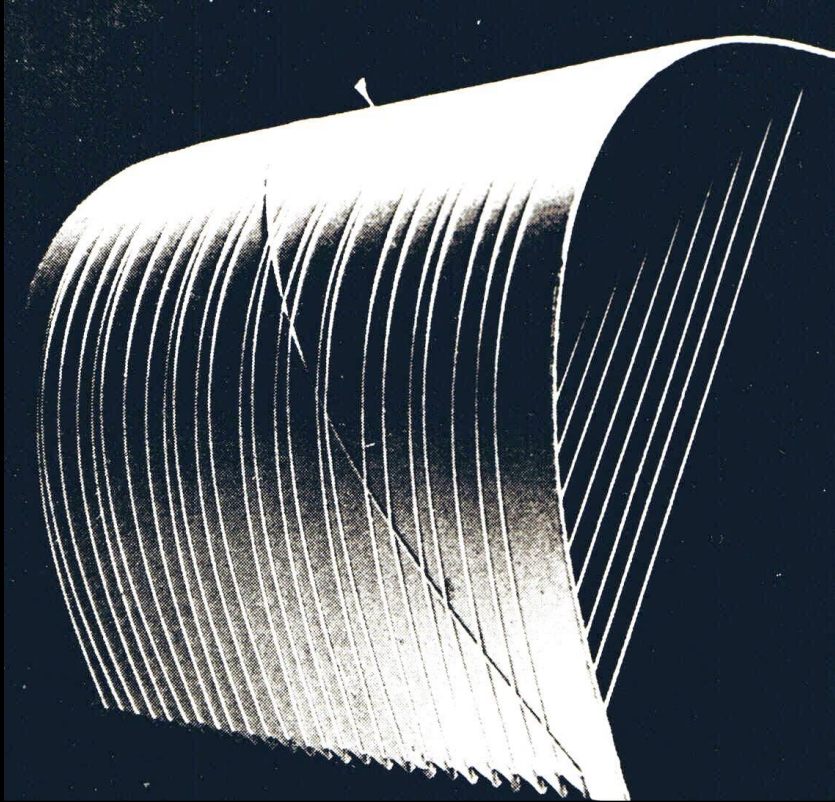





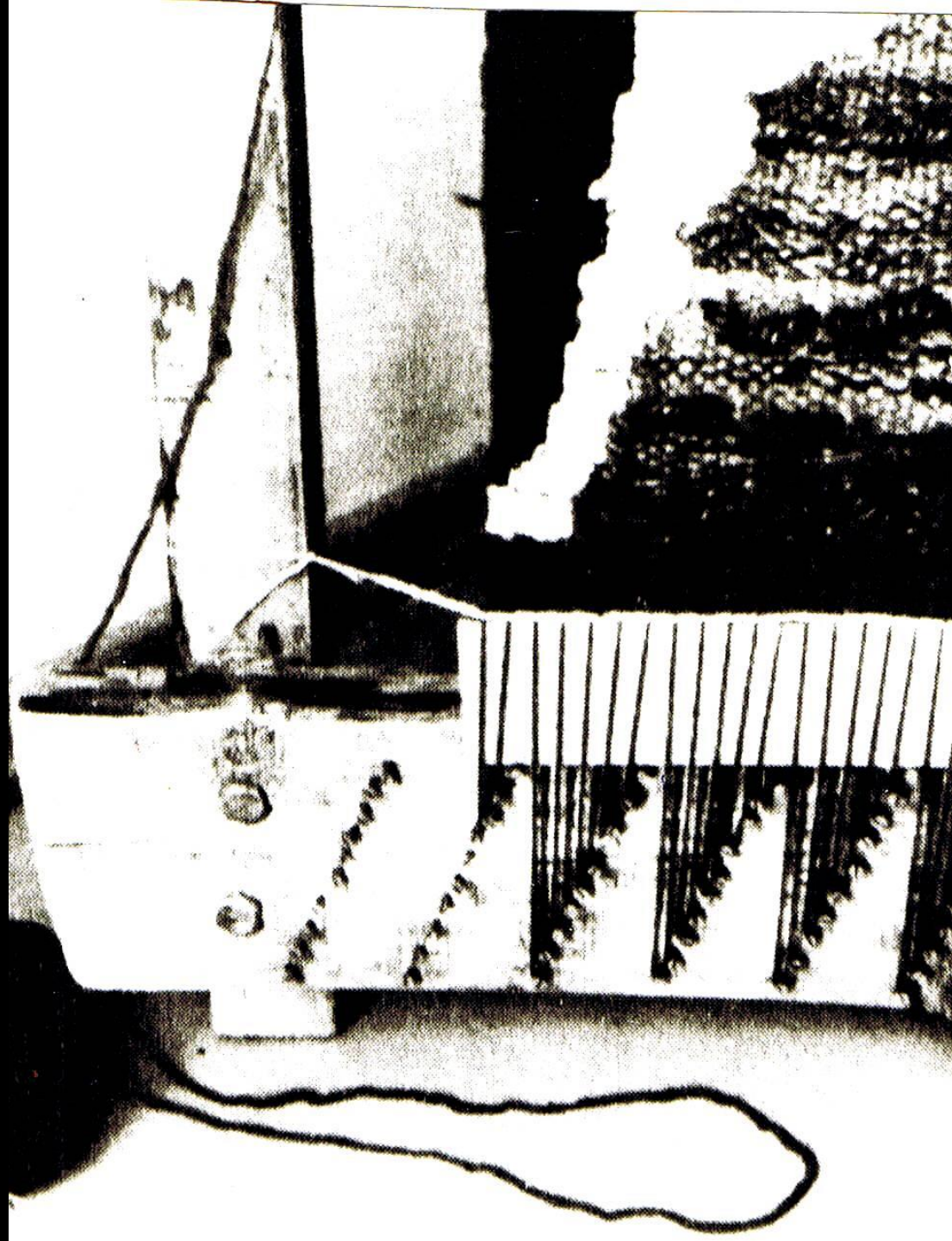
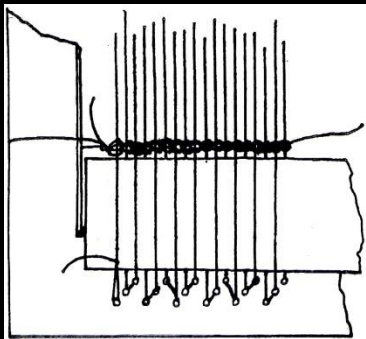
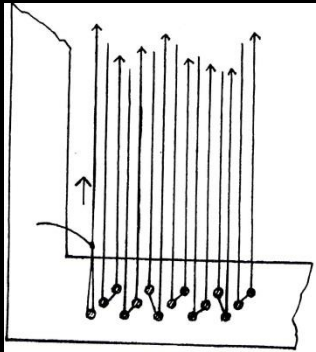
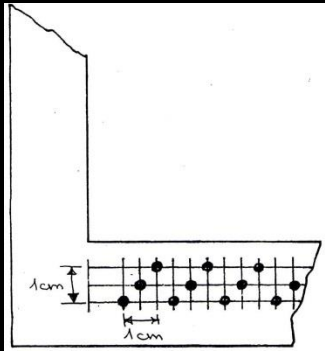

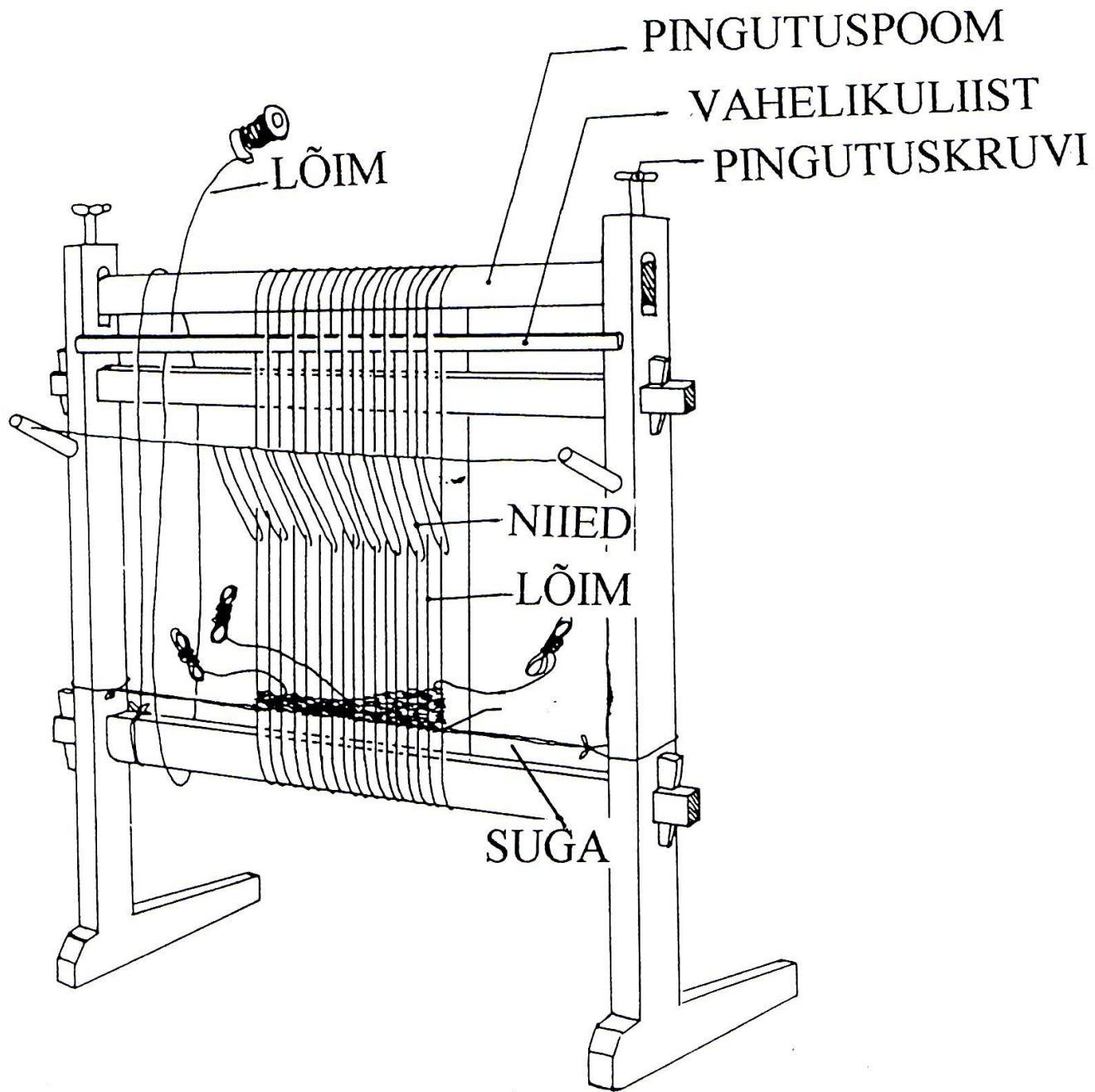

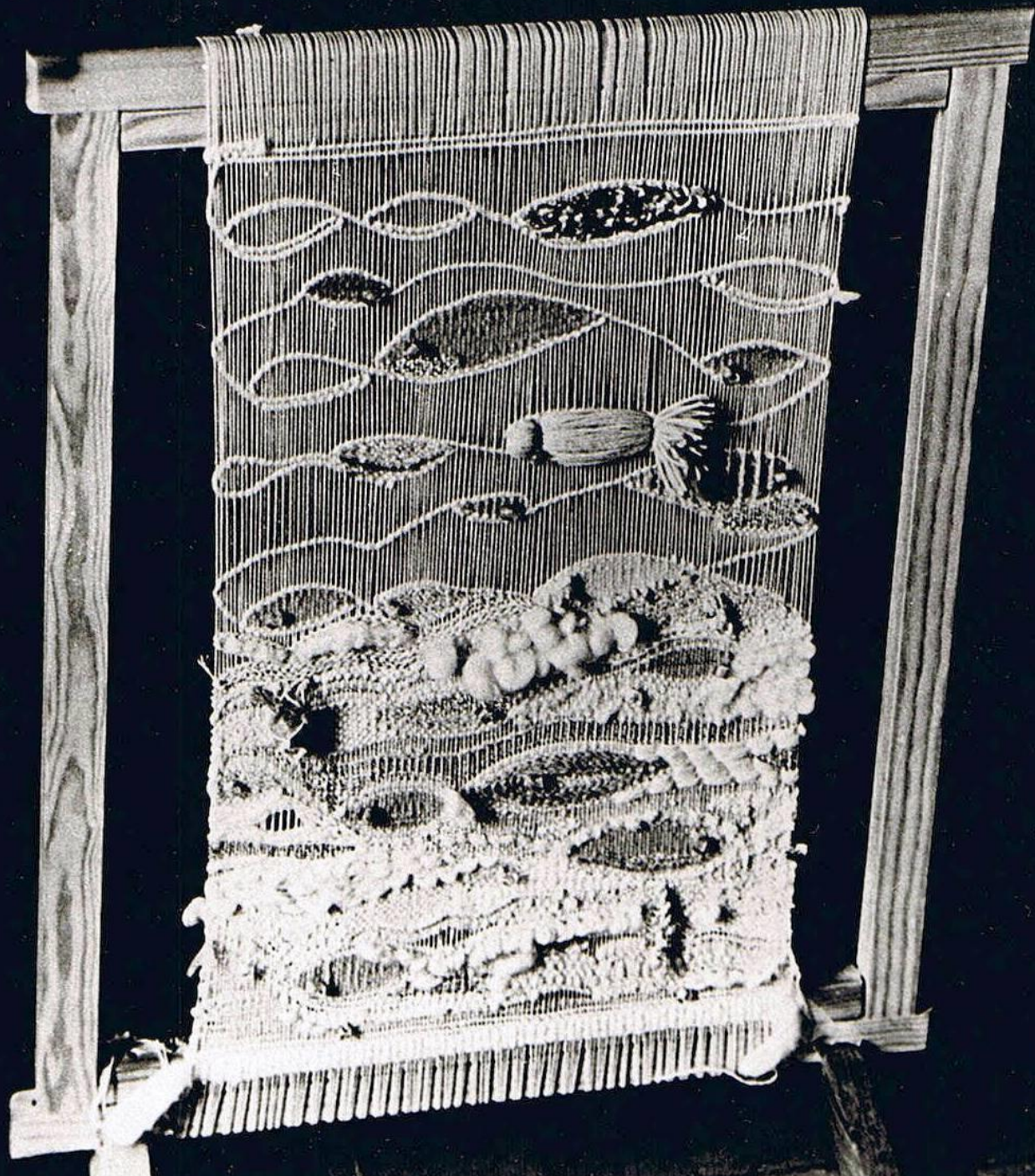

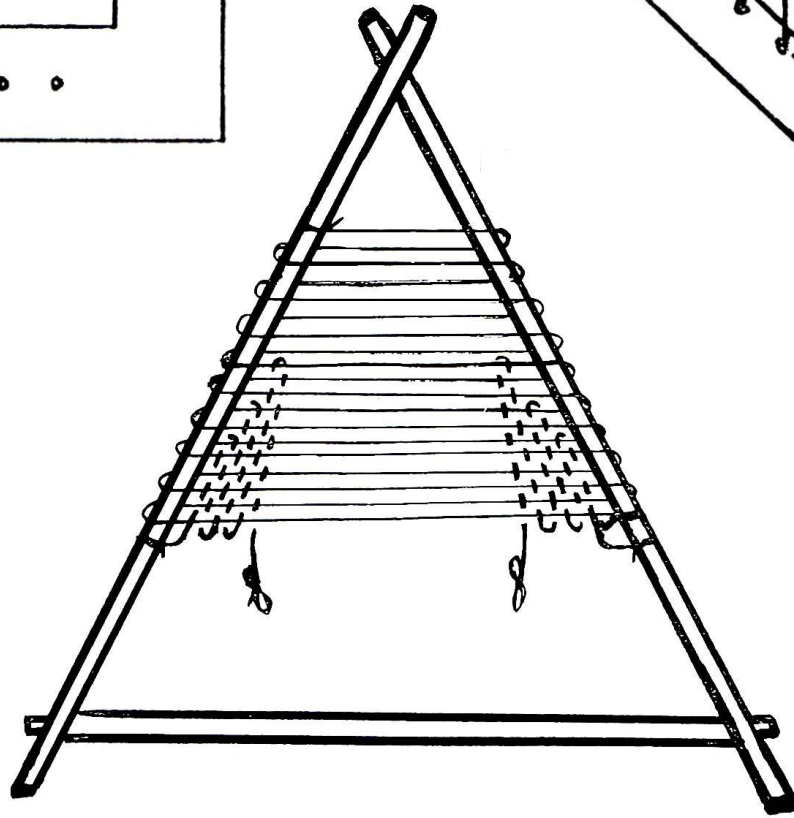
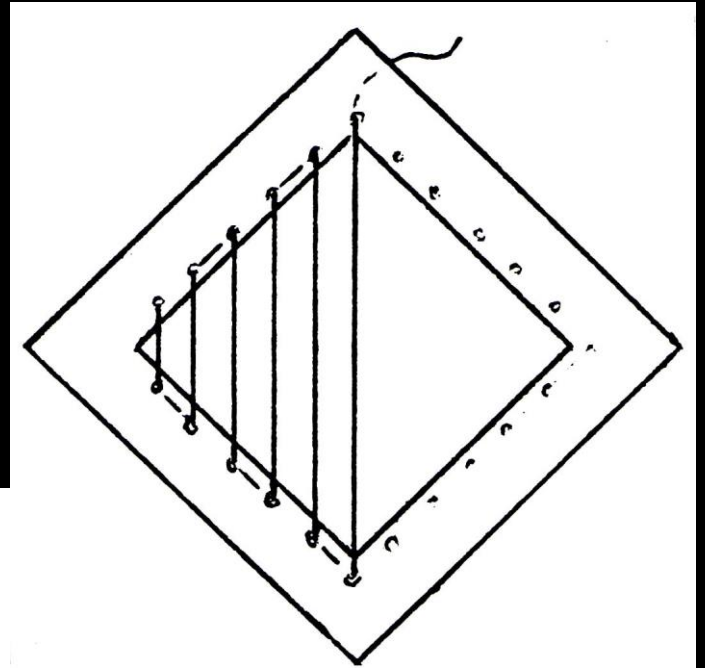
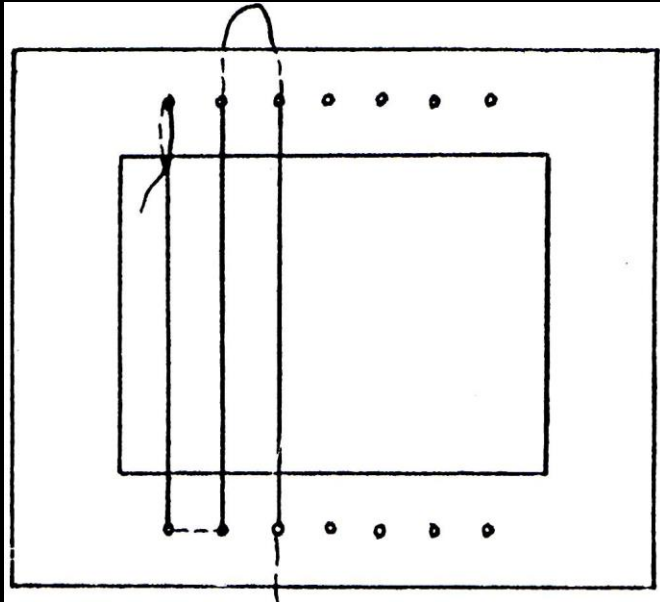



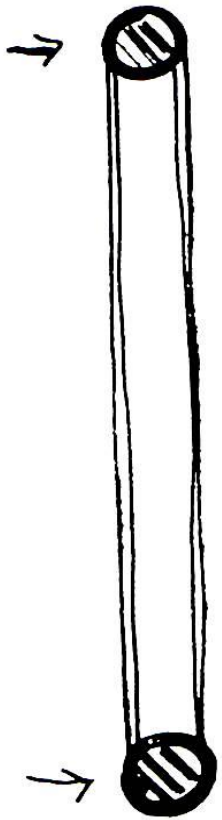
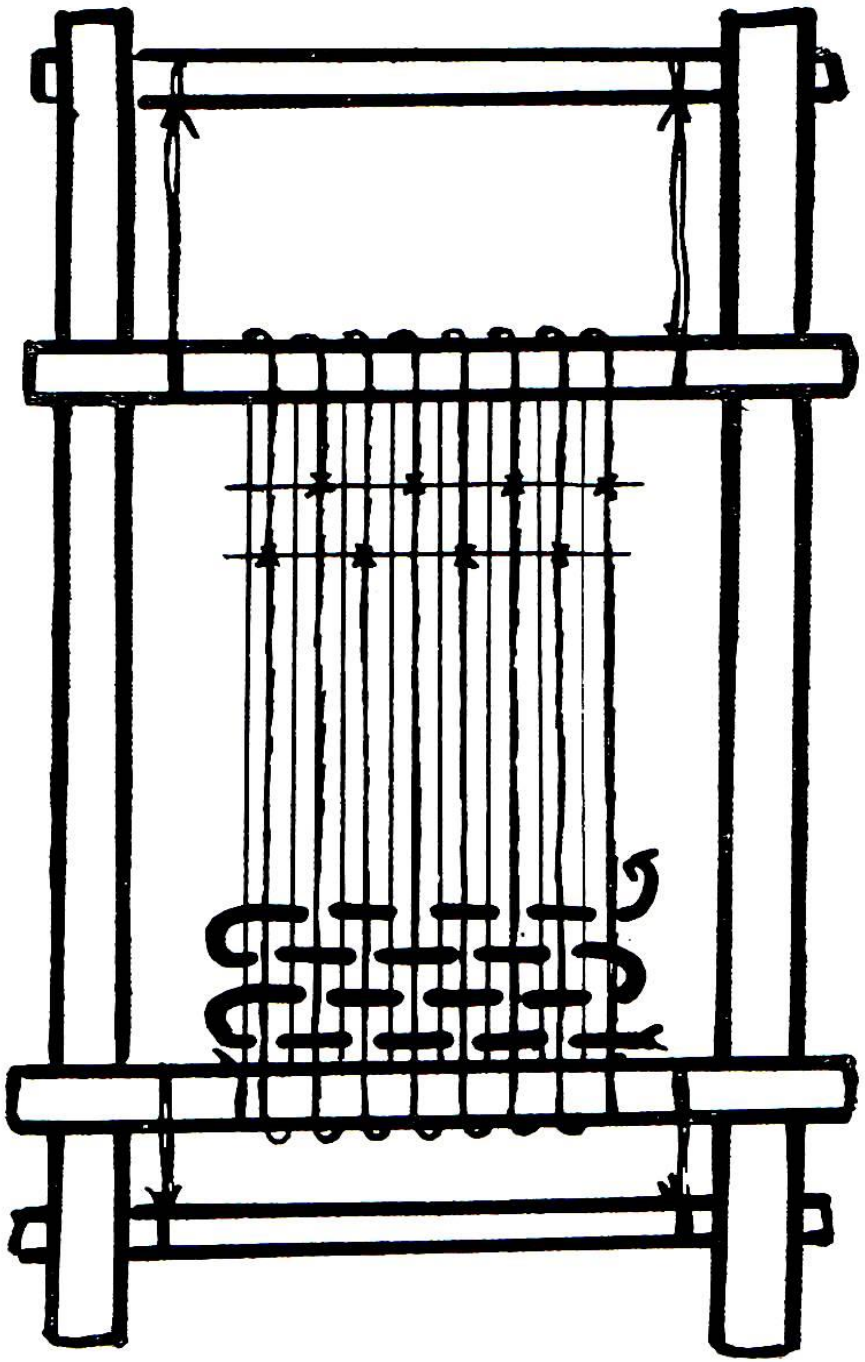

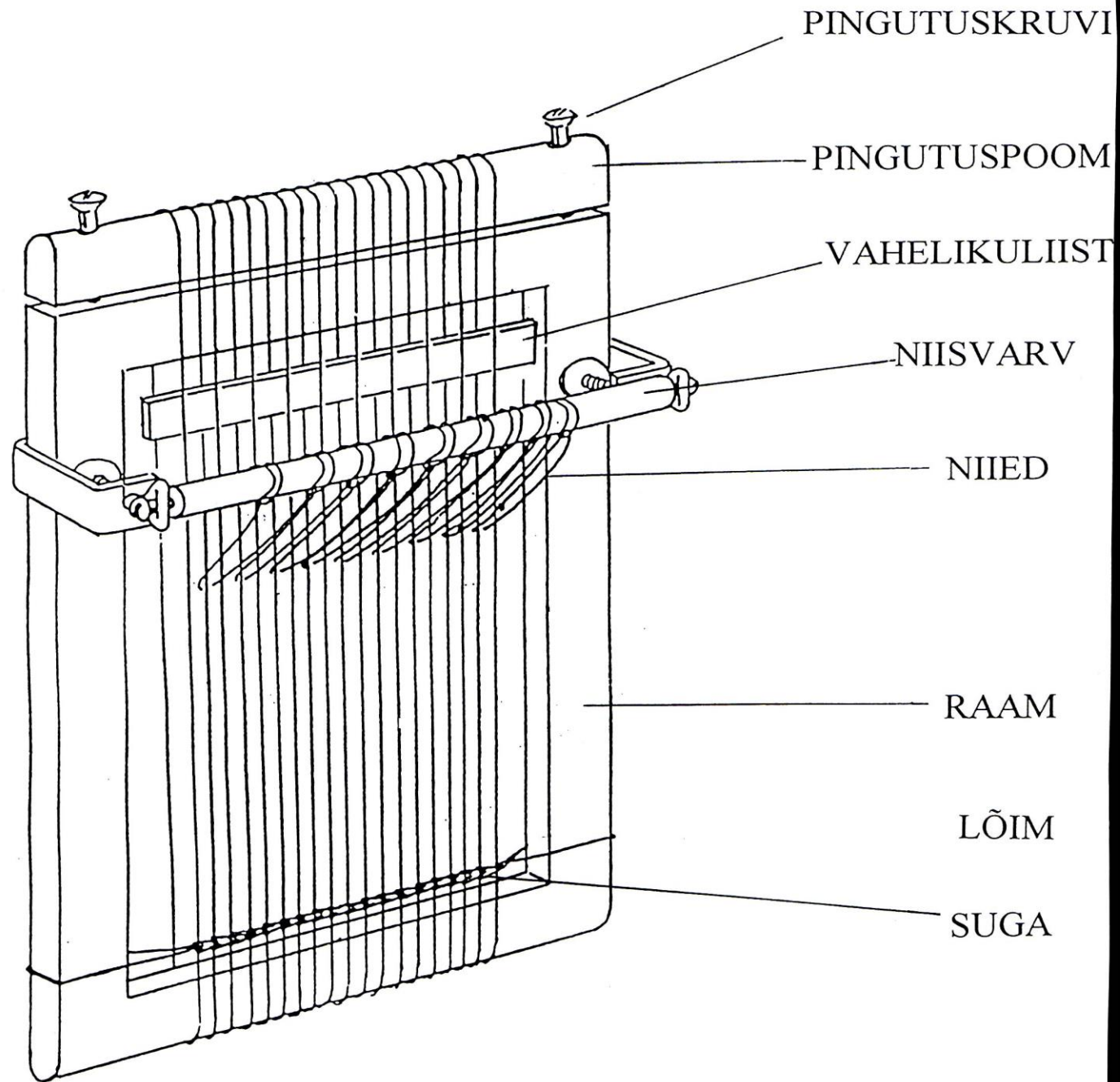

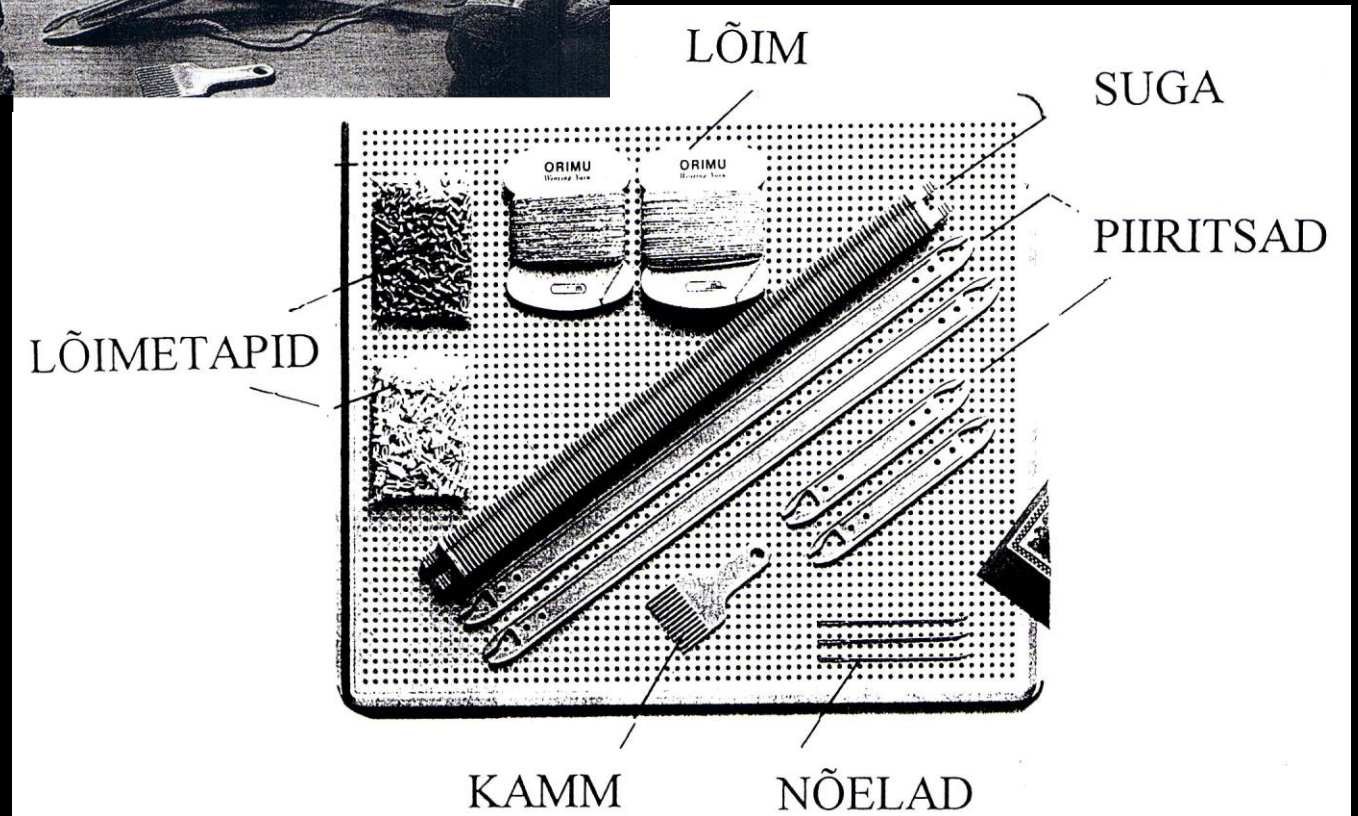
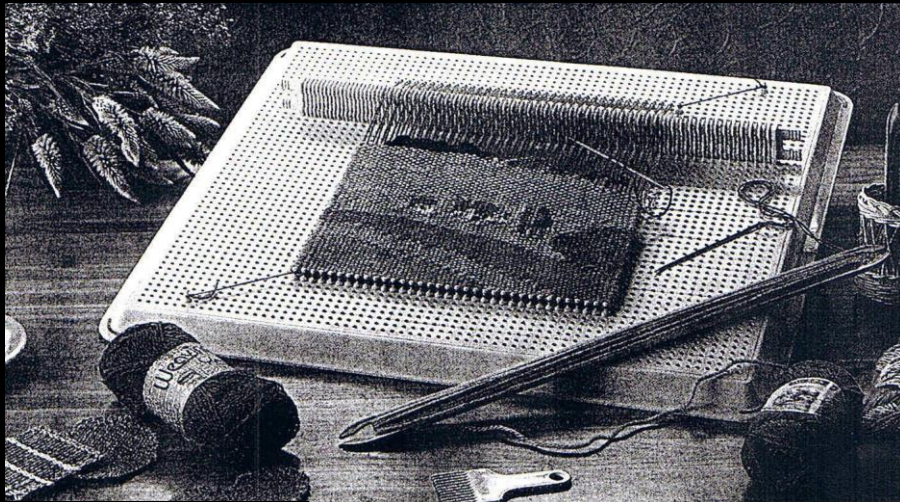

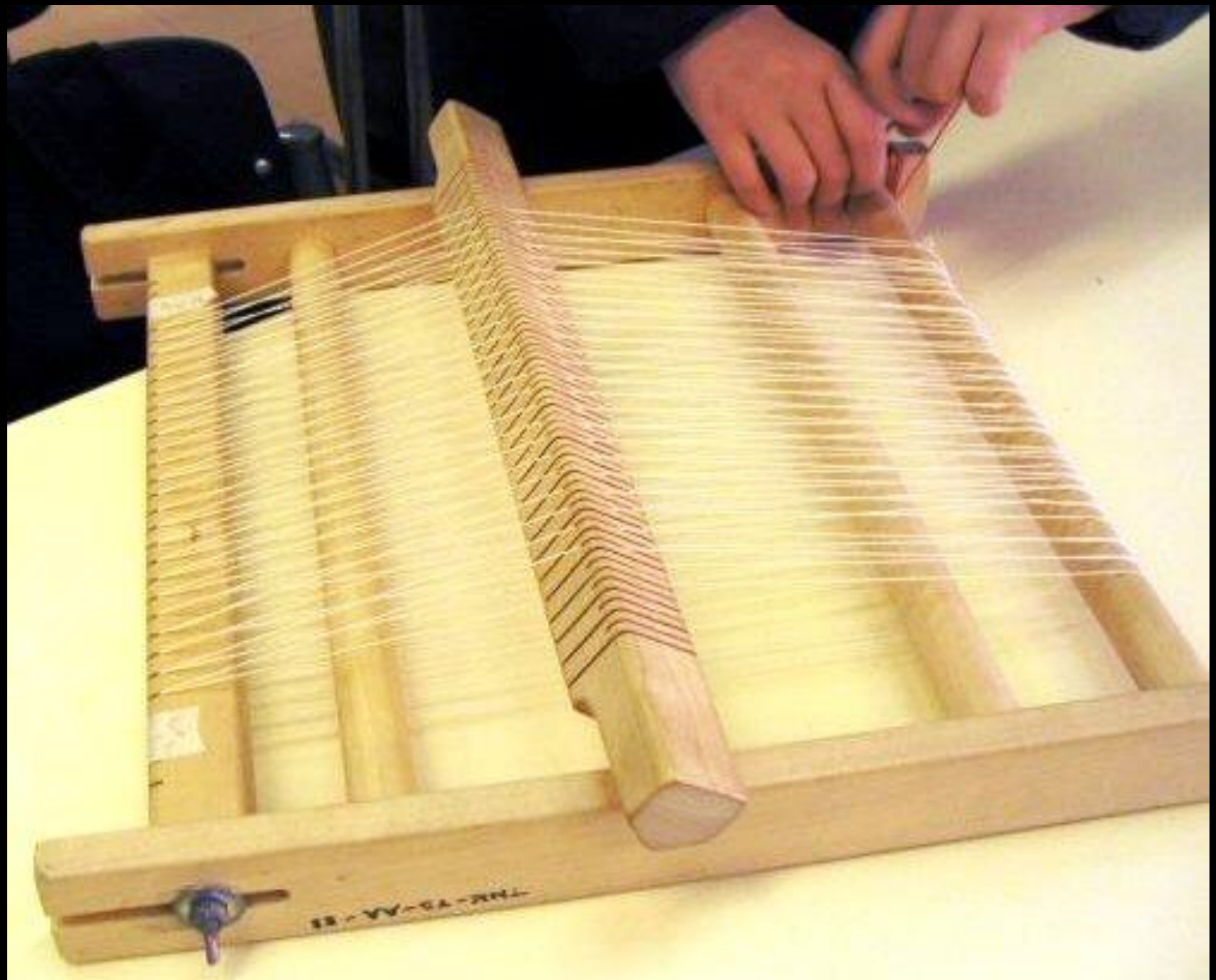

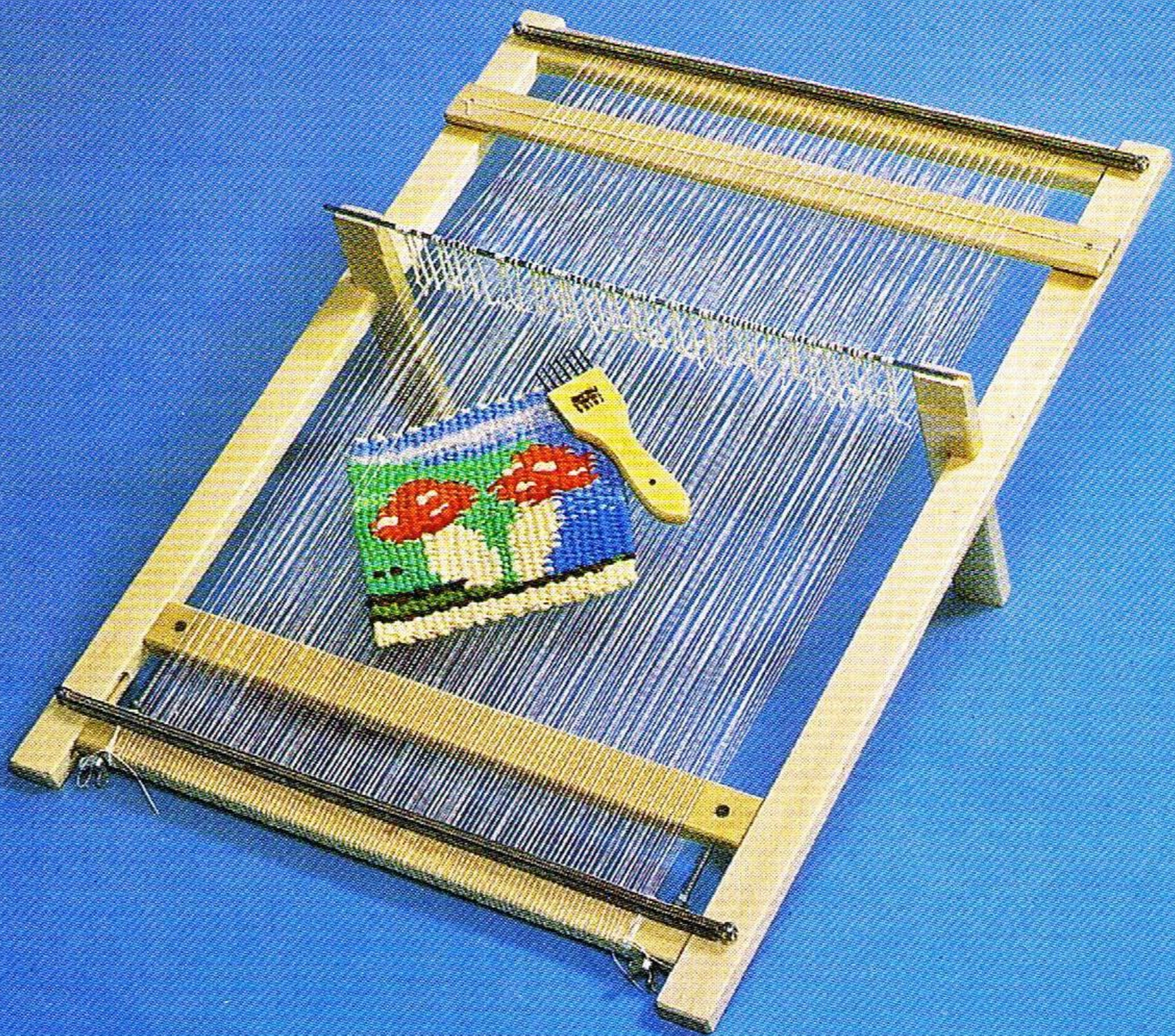

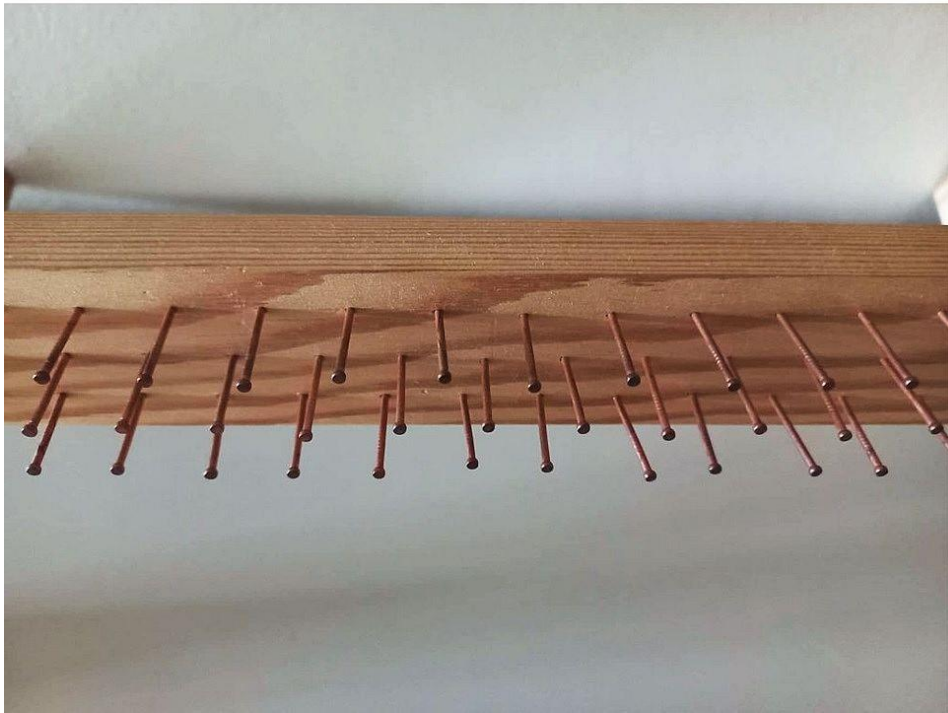

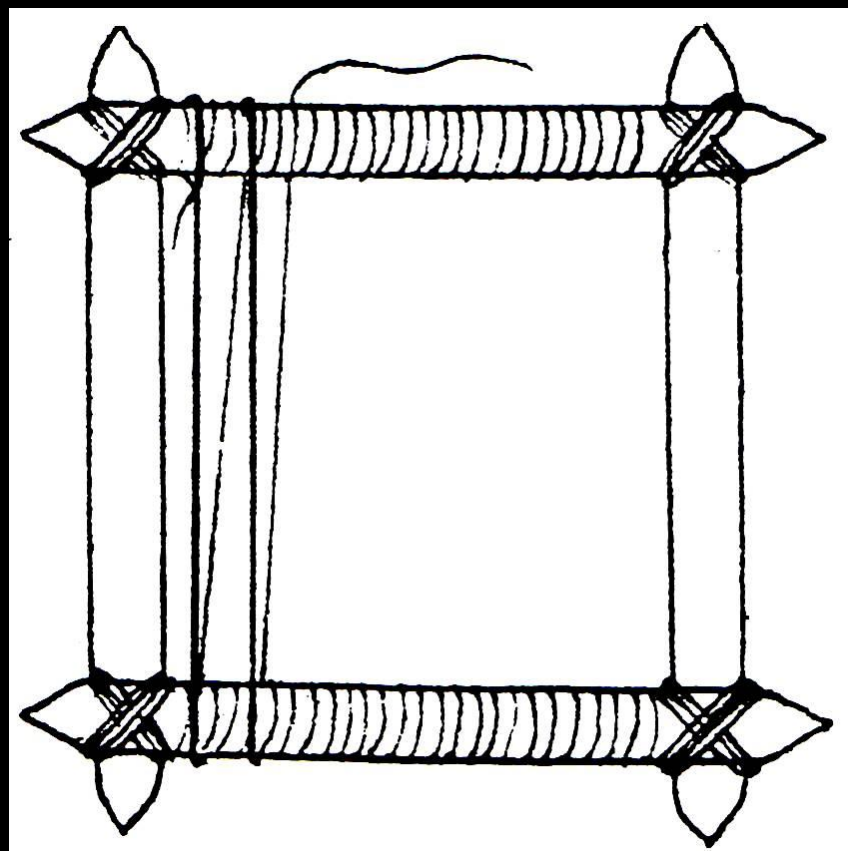
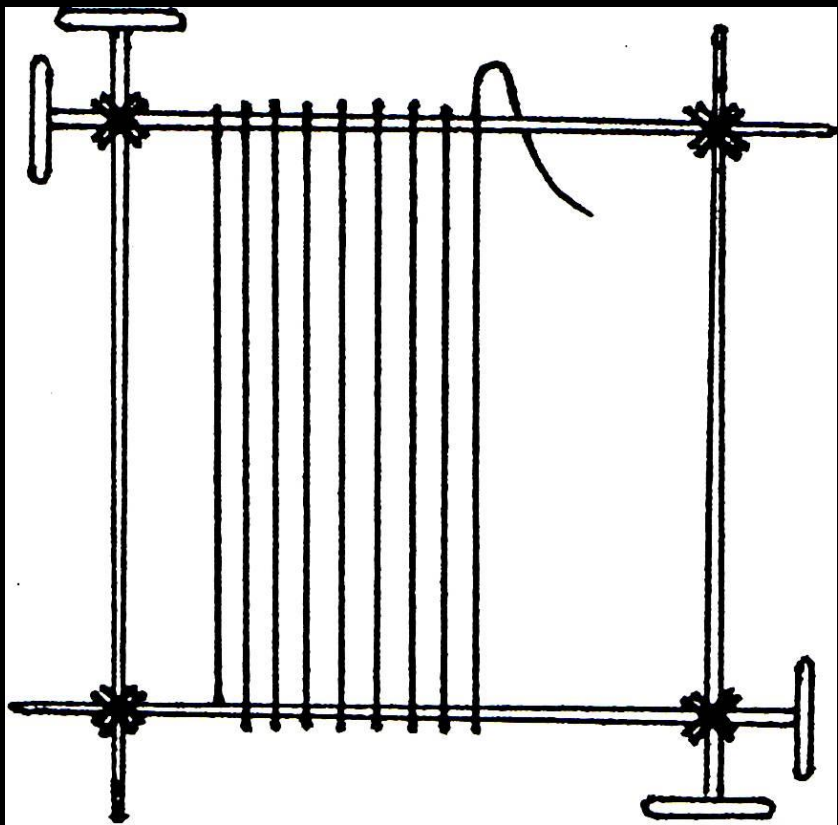
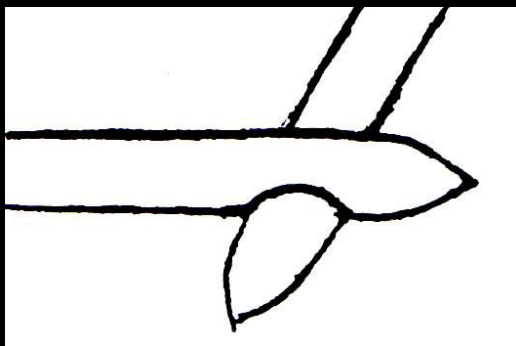

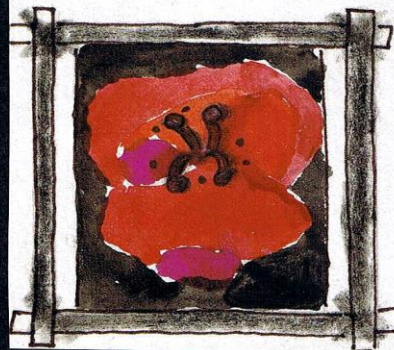
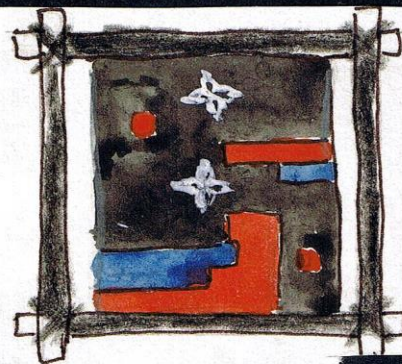
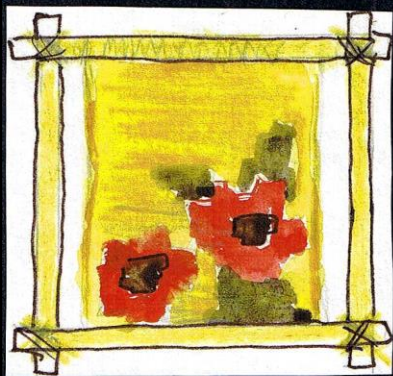

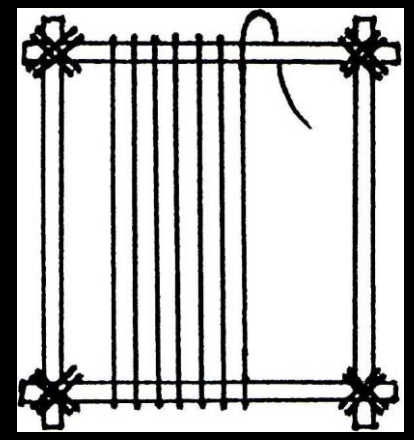
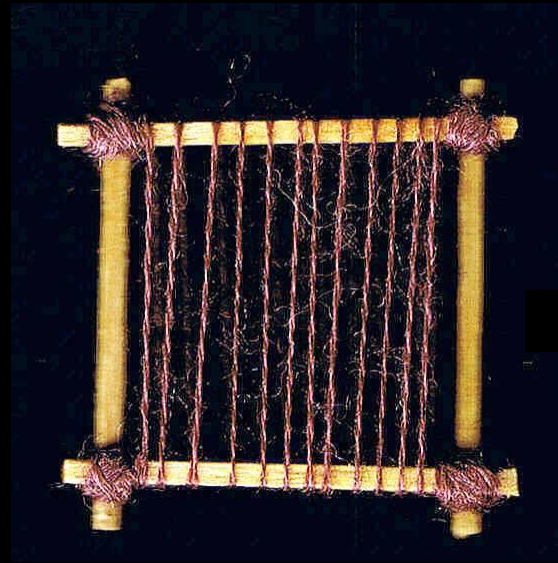
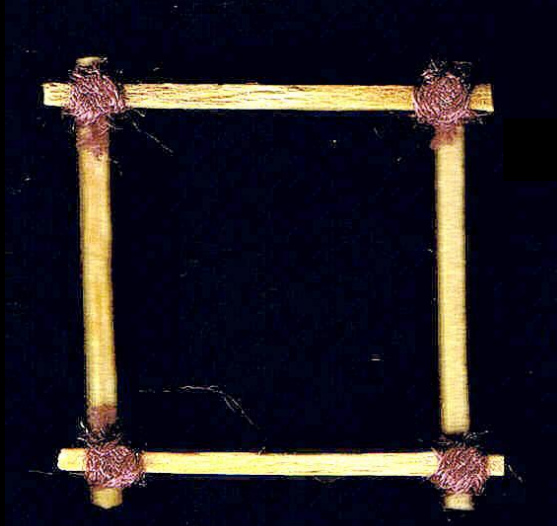
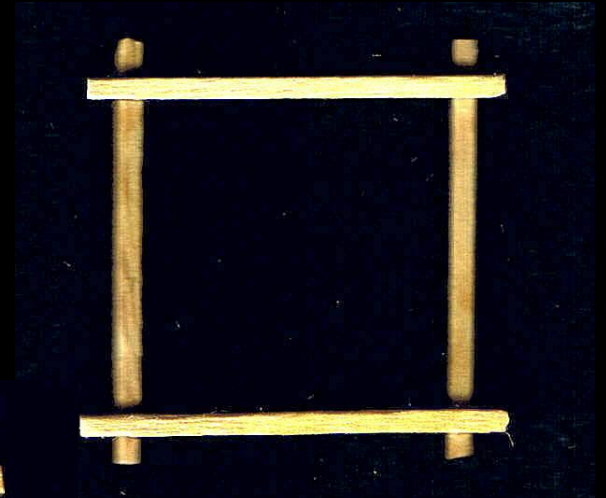
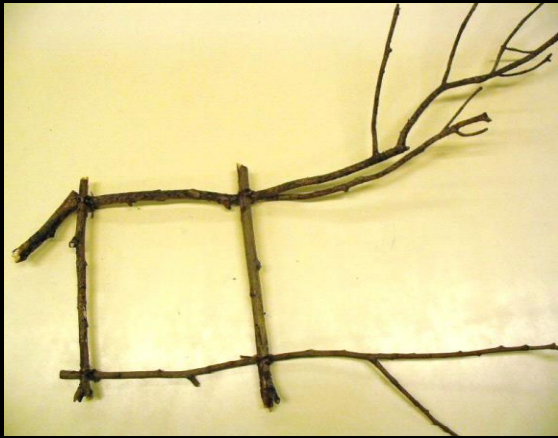





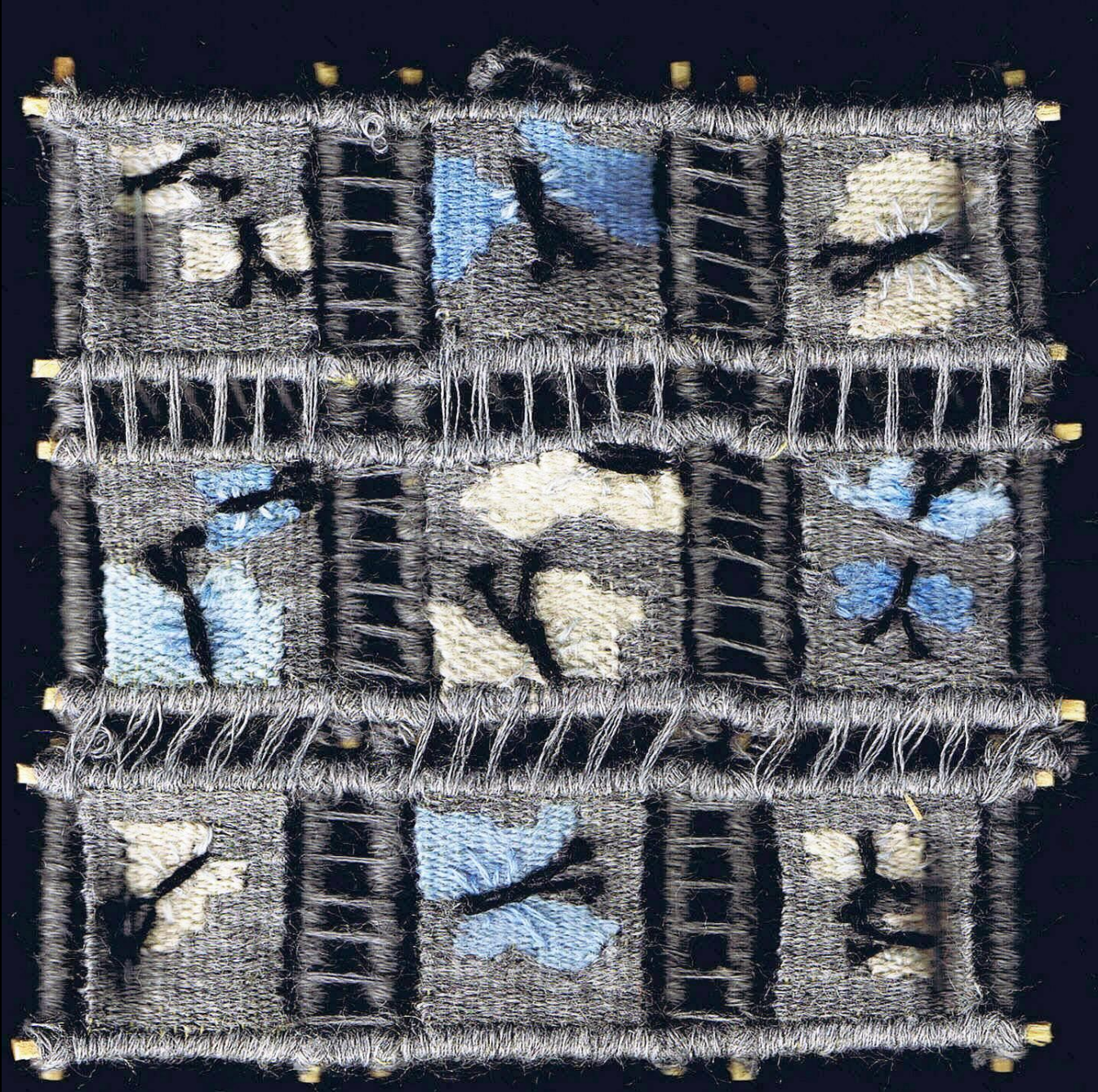
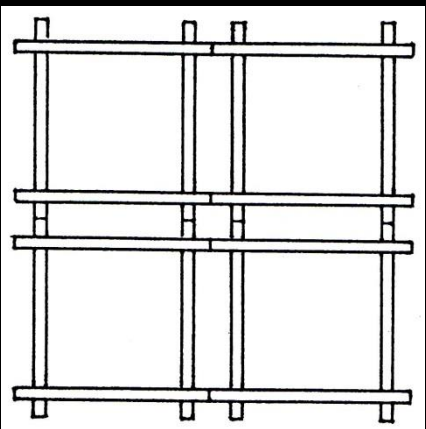

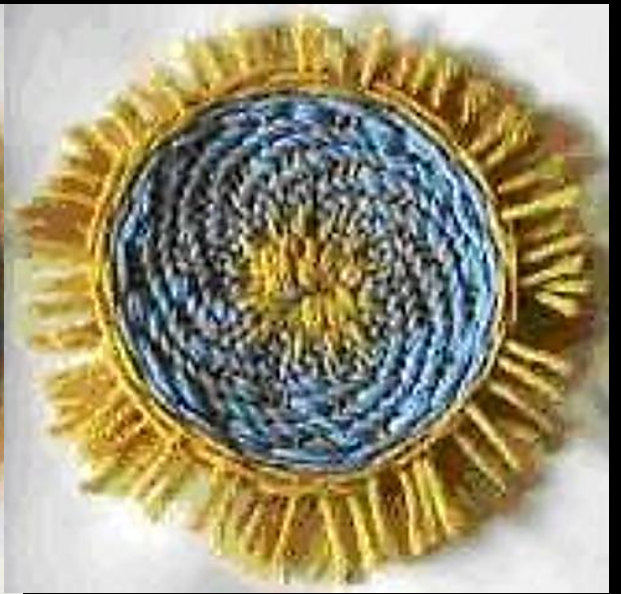
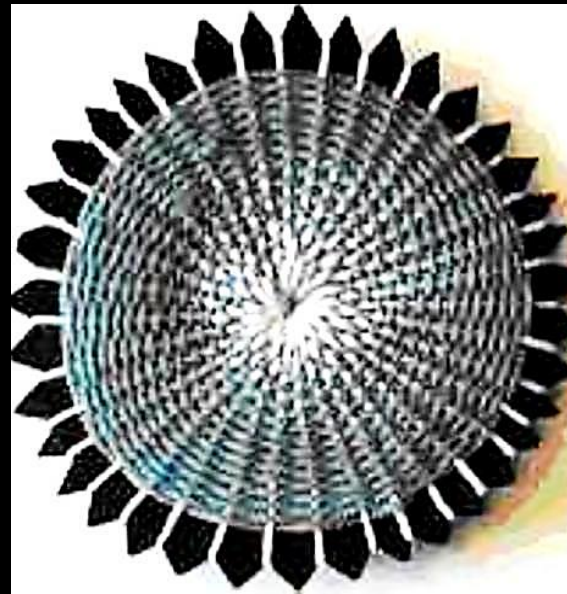
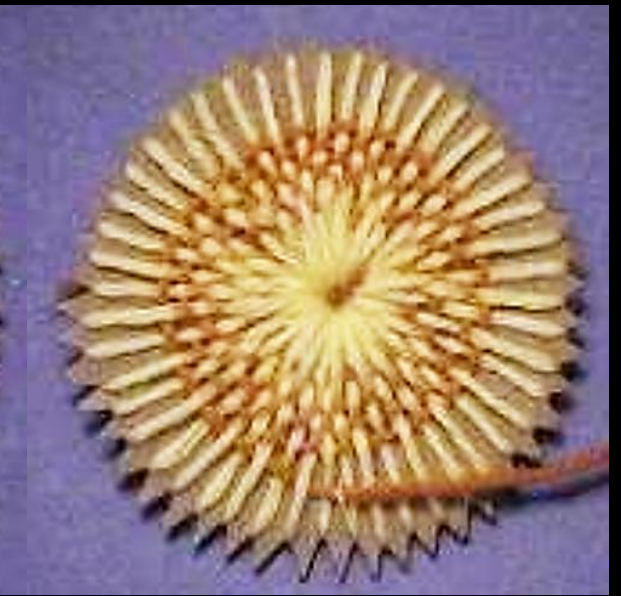
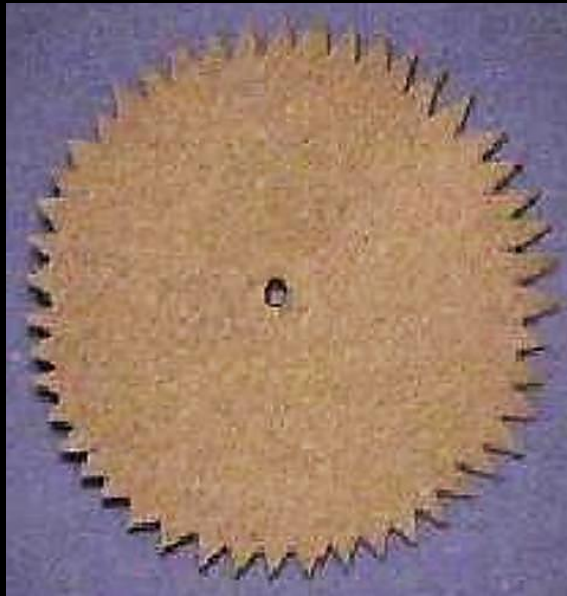



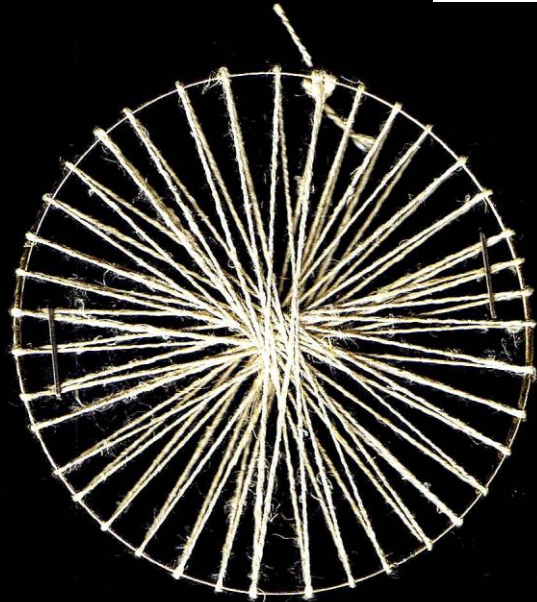
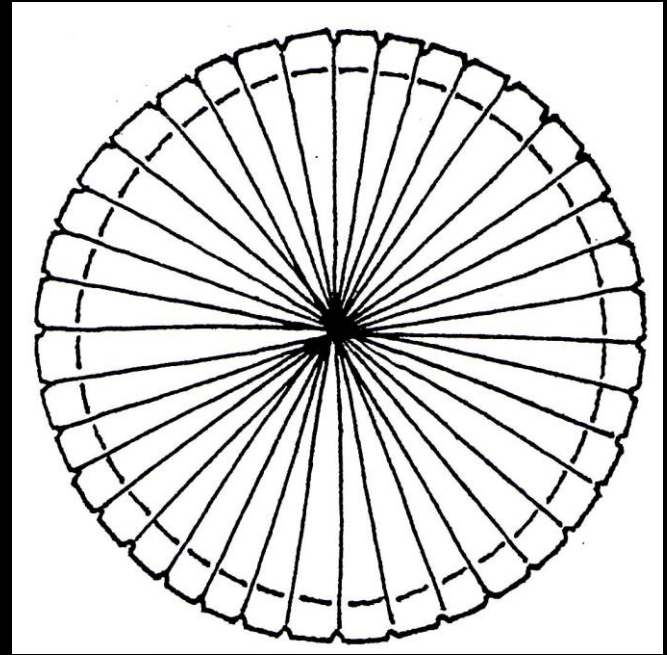
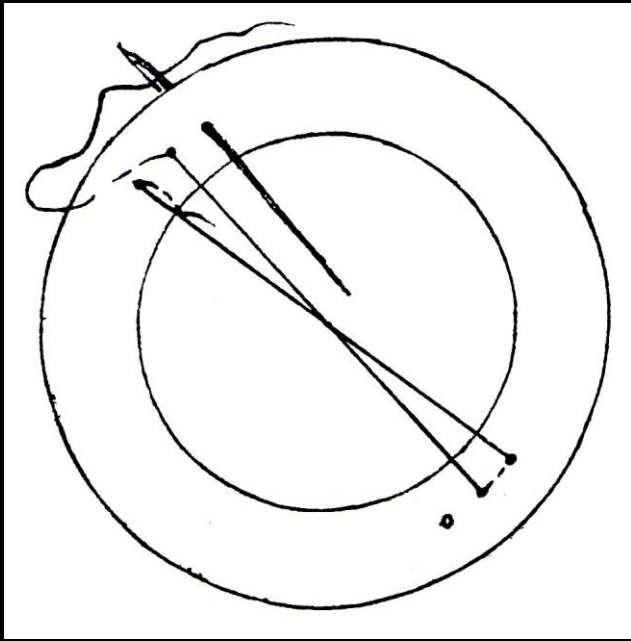





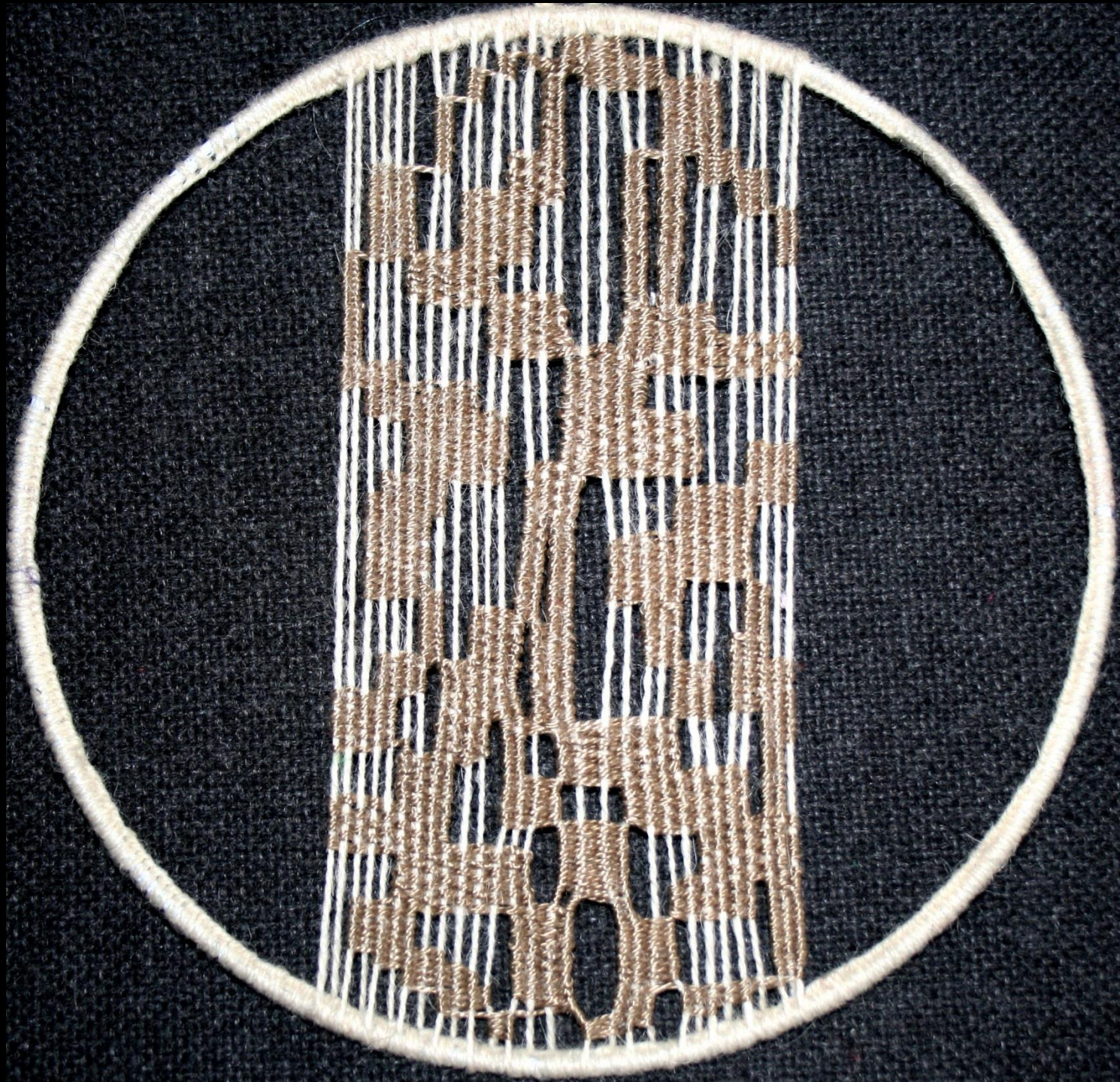

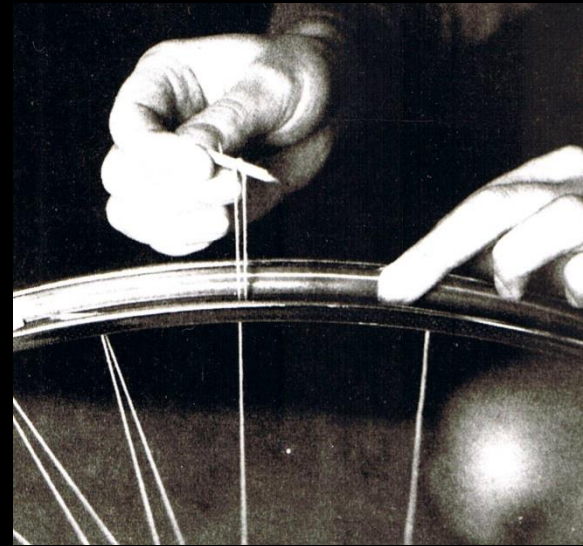
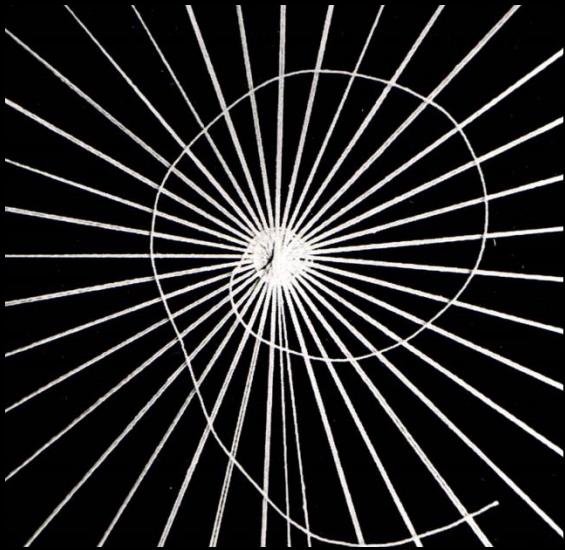
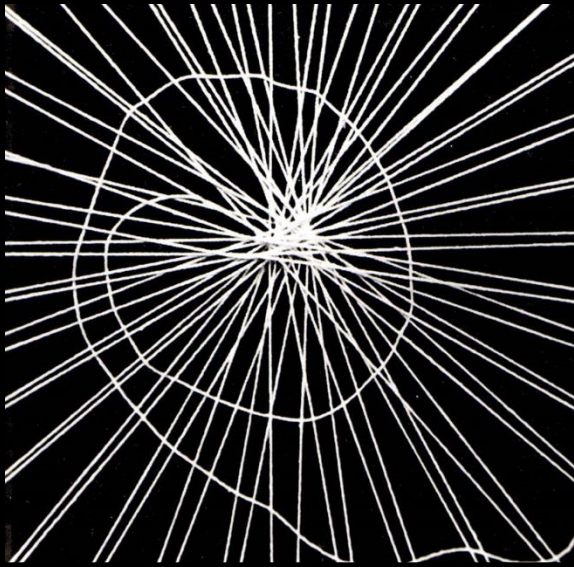

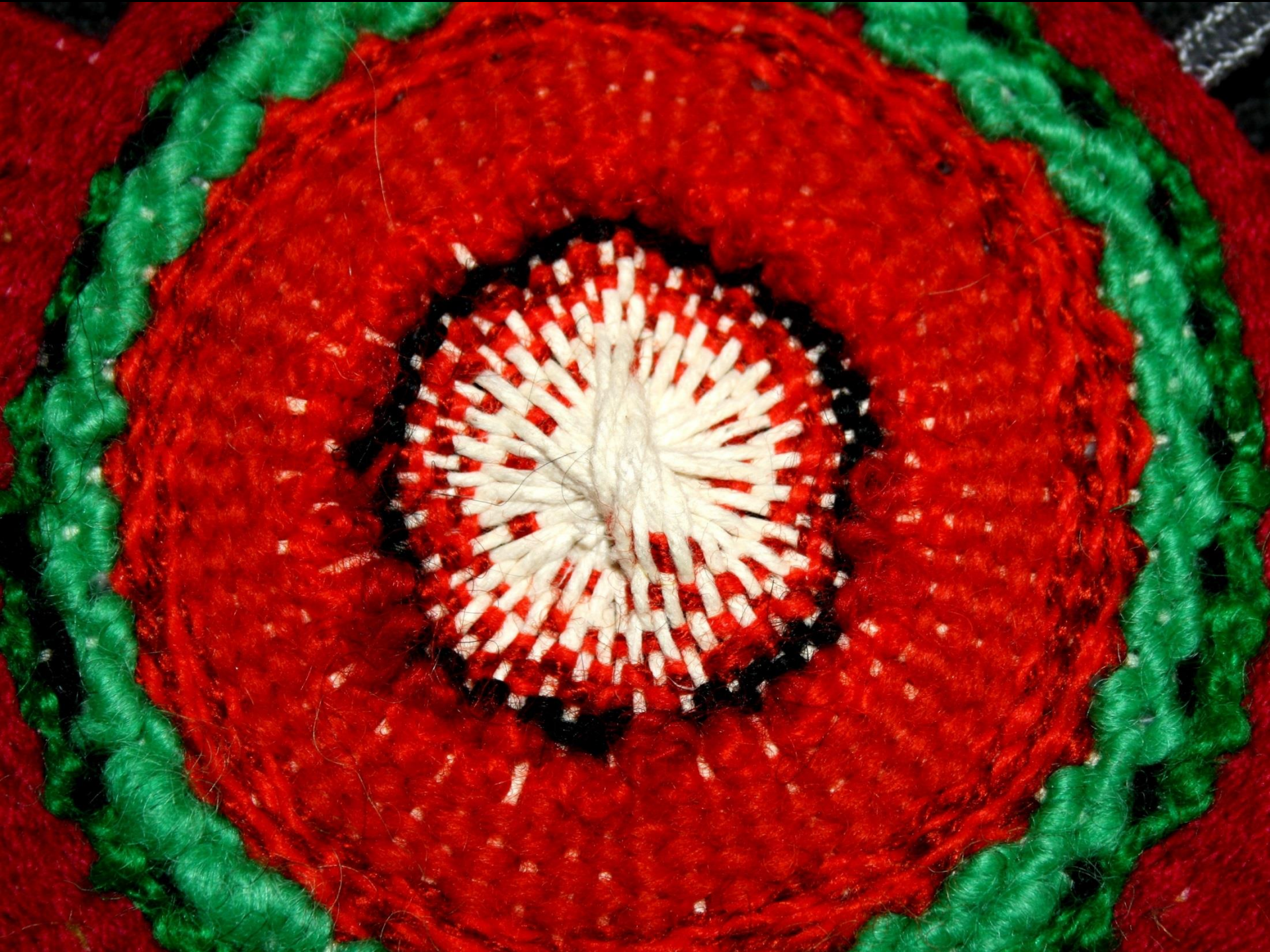

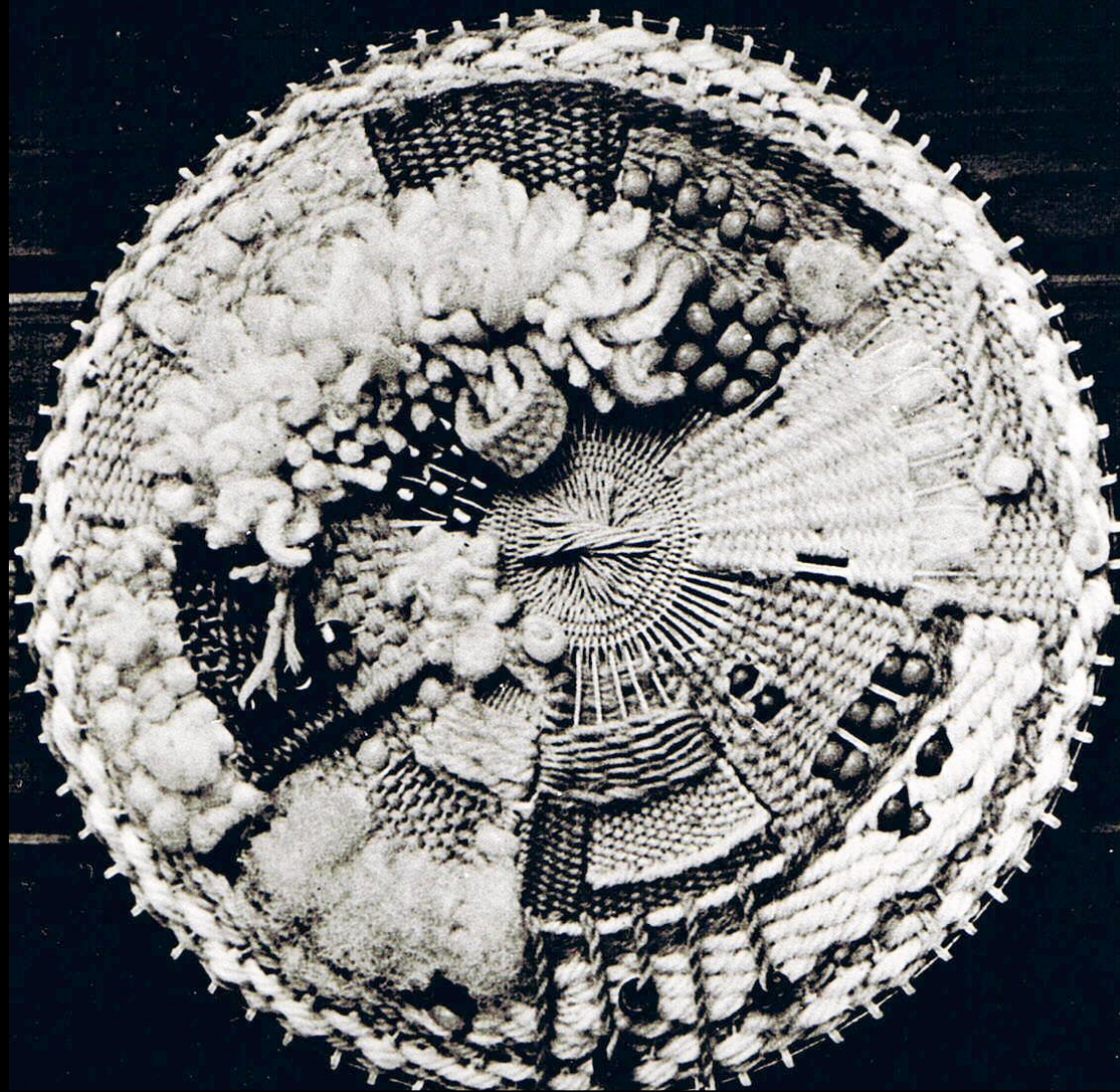
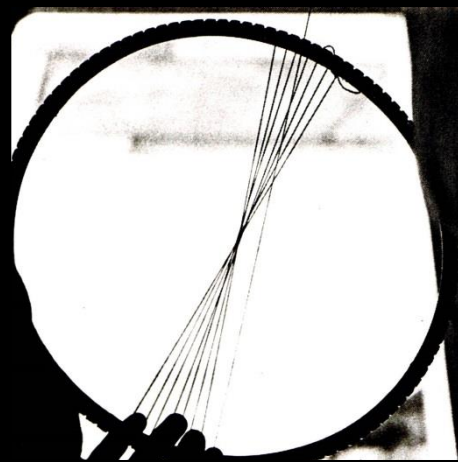





Annika Kangur



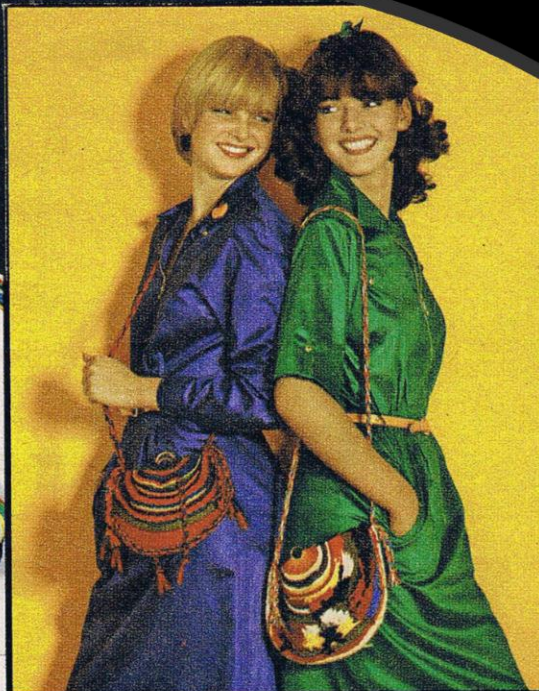

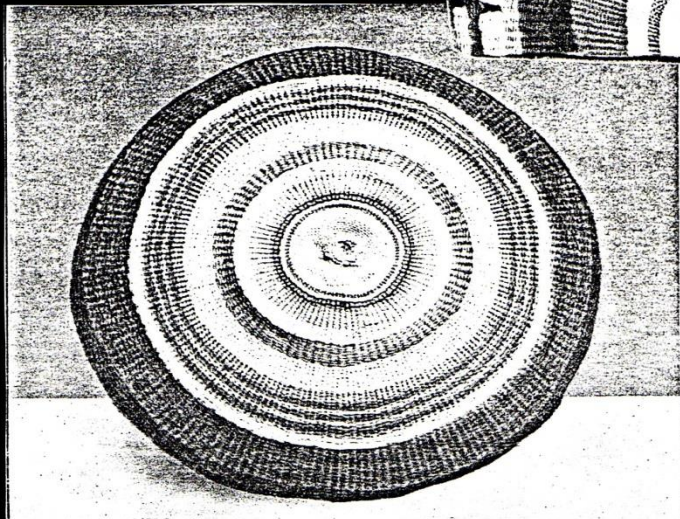
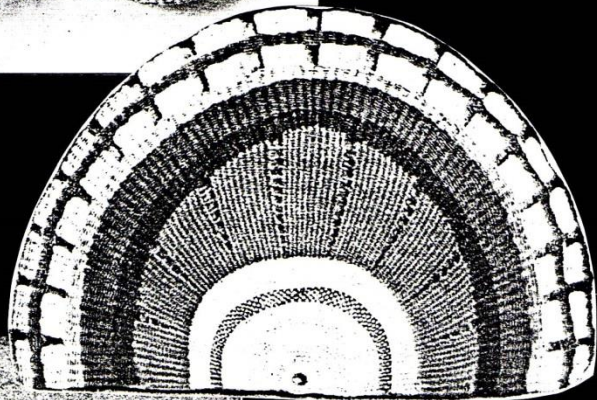
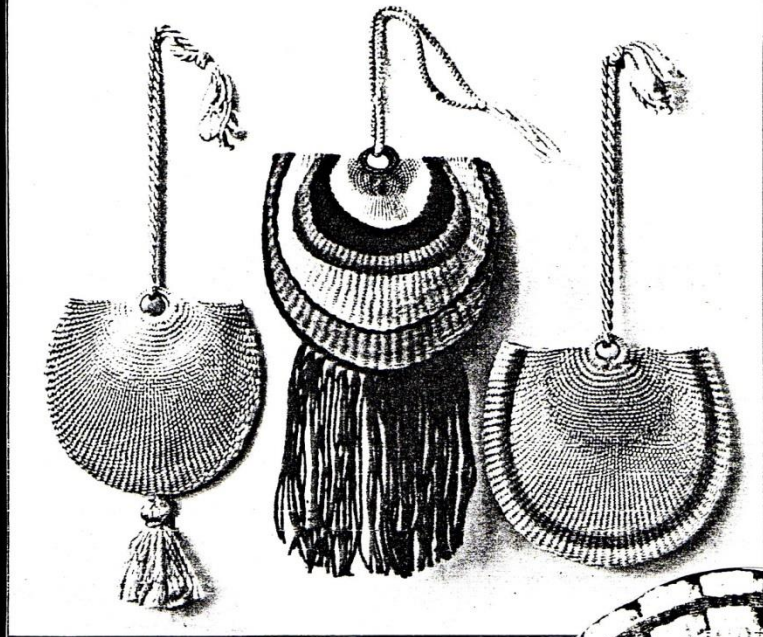

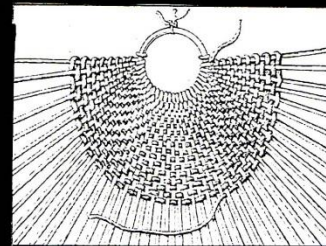
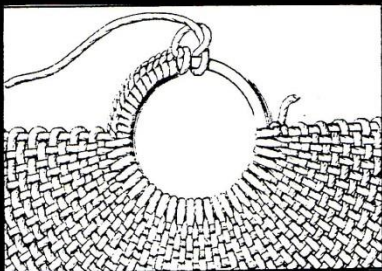
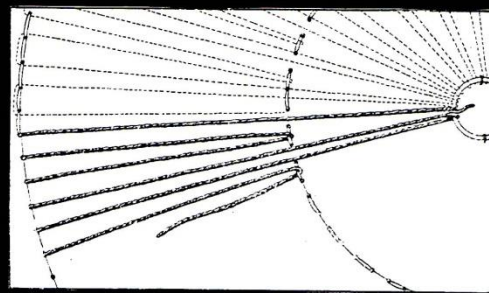
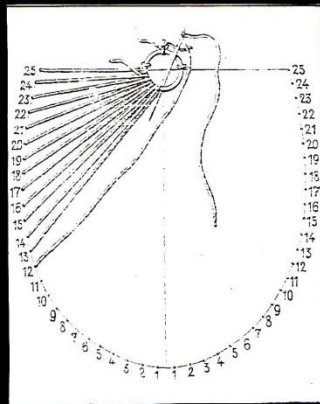
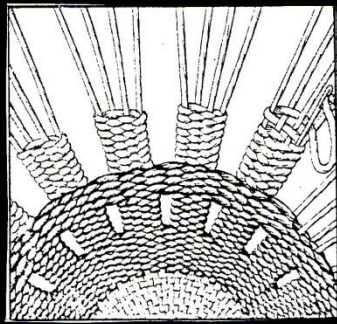
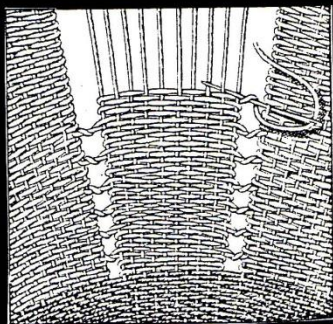
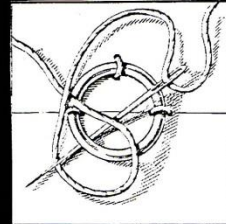
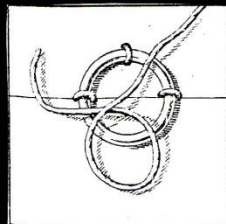
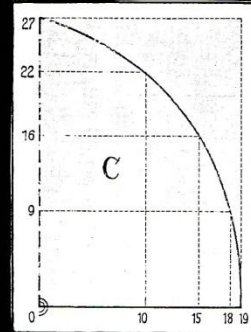
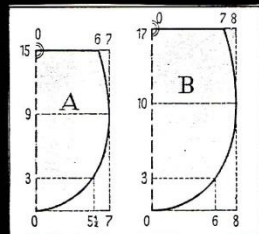
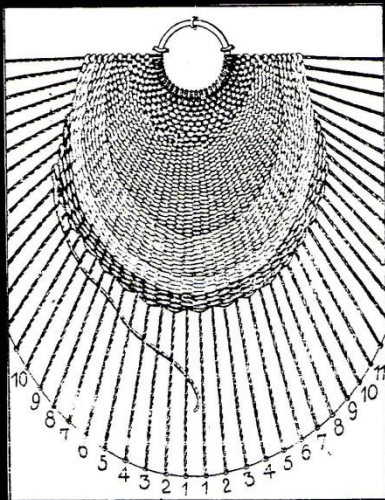
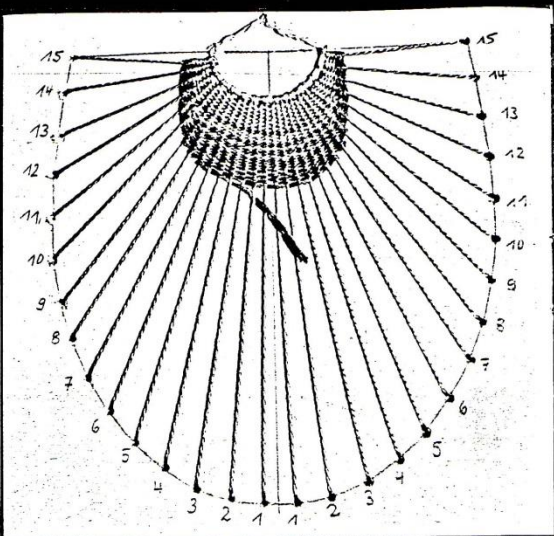



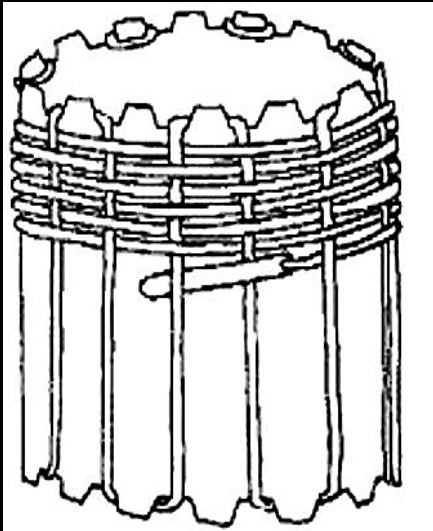

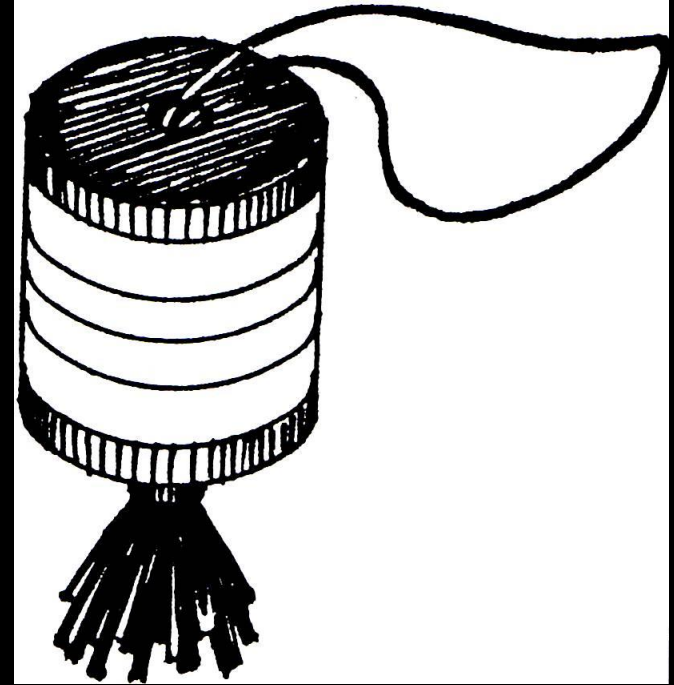
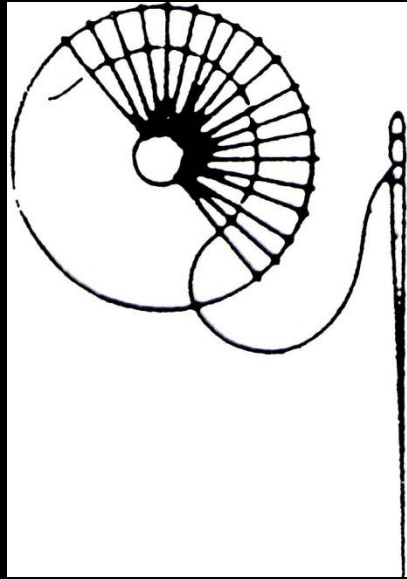
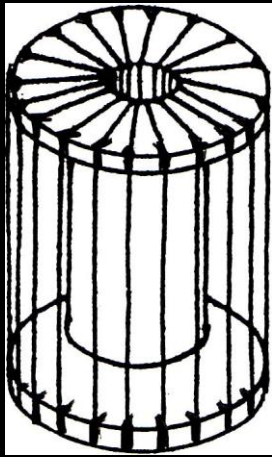
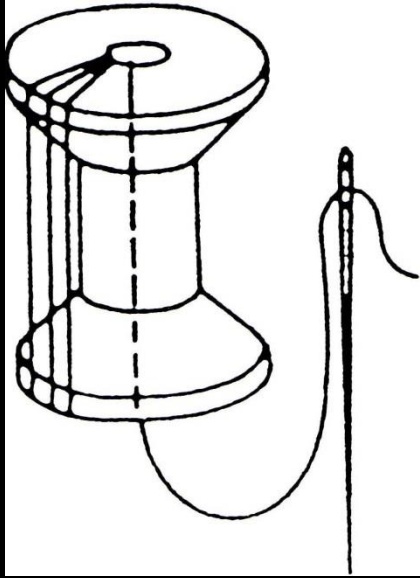



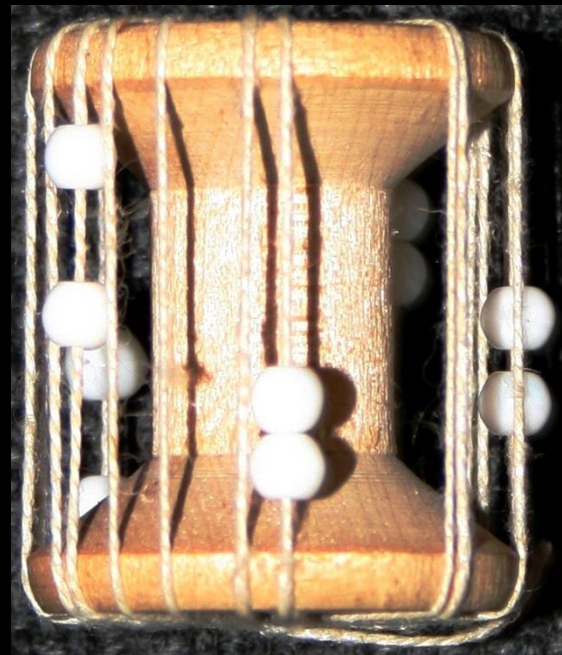

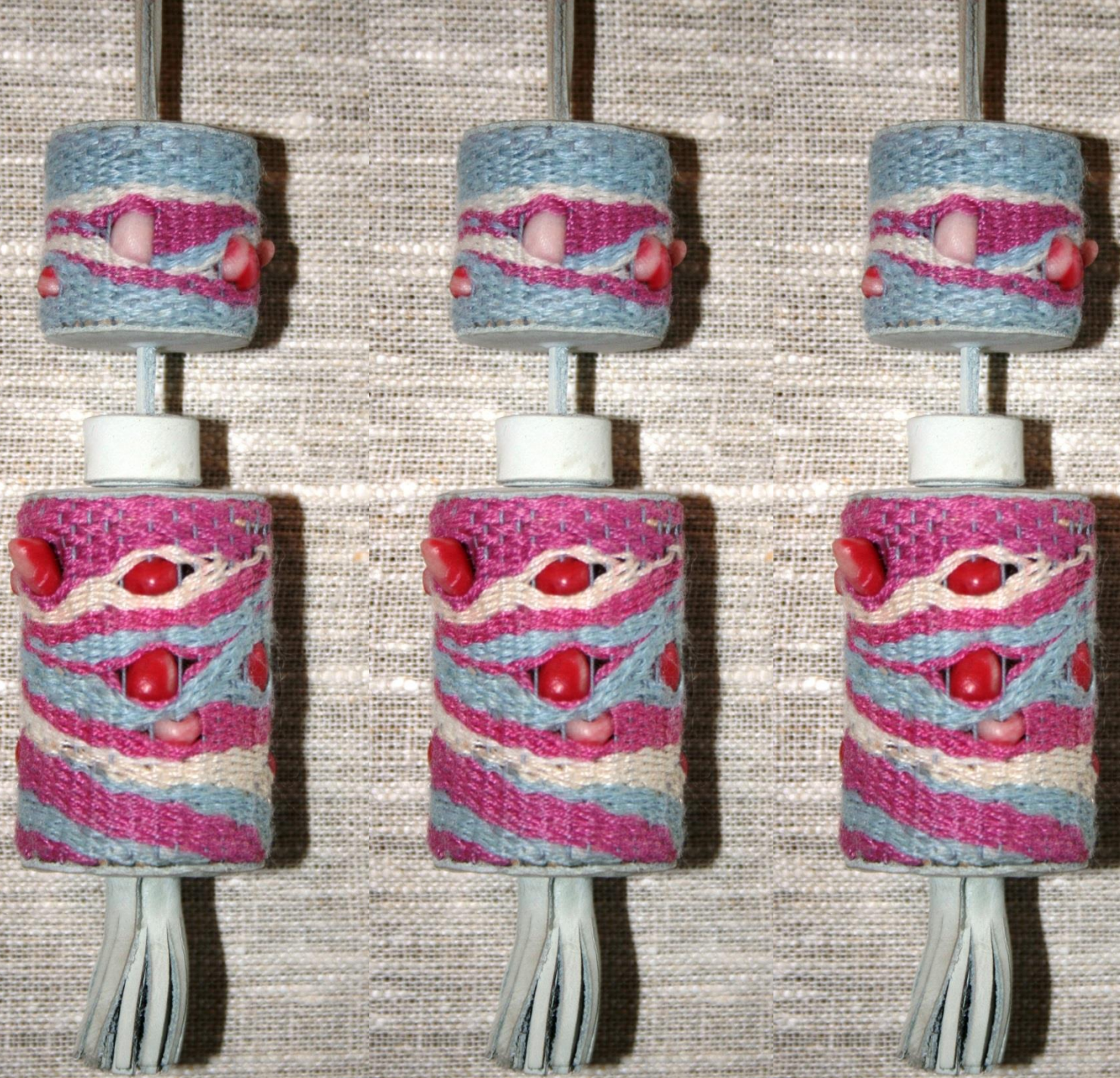

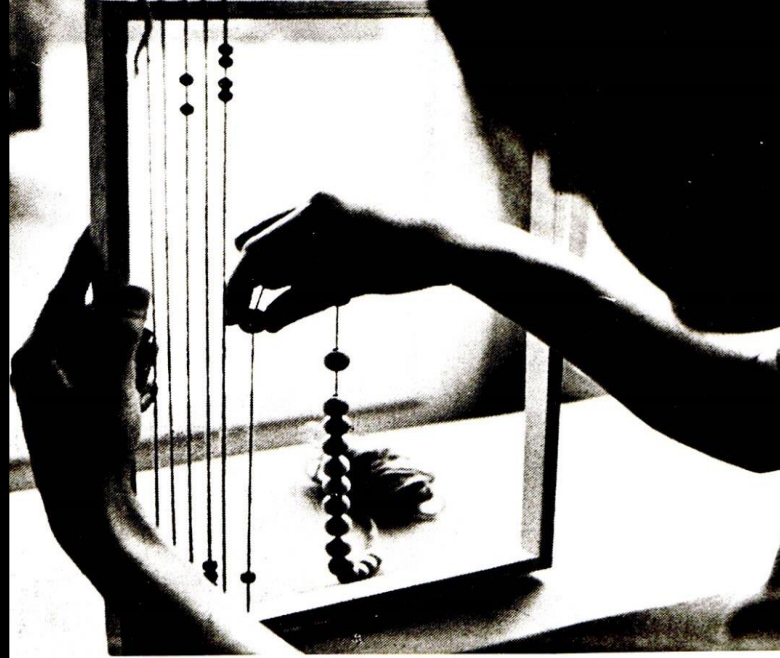



LÕIME VEDAMINE RAAMILE

1. Seo lõime algusots raami külge!
2. Vea lõim ühtlase pingega ja 1 cm vahedega ümber raami!
3. Esimene ja viimane lõimelõng vea 2x-lt ümber raami!
4. Seo lõime lõpuots raami külge (algusotsaga samale küljele)!

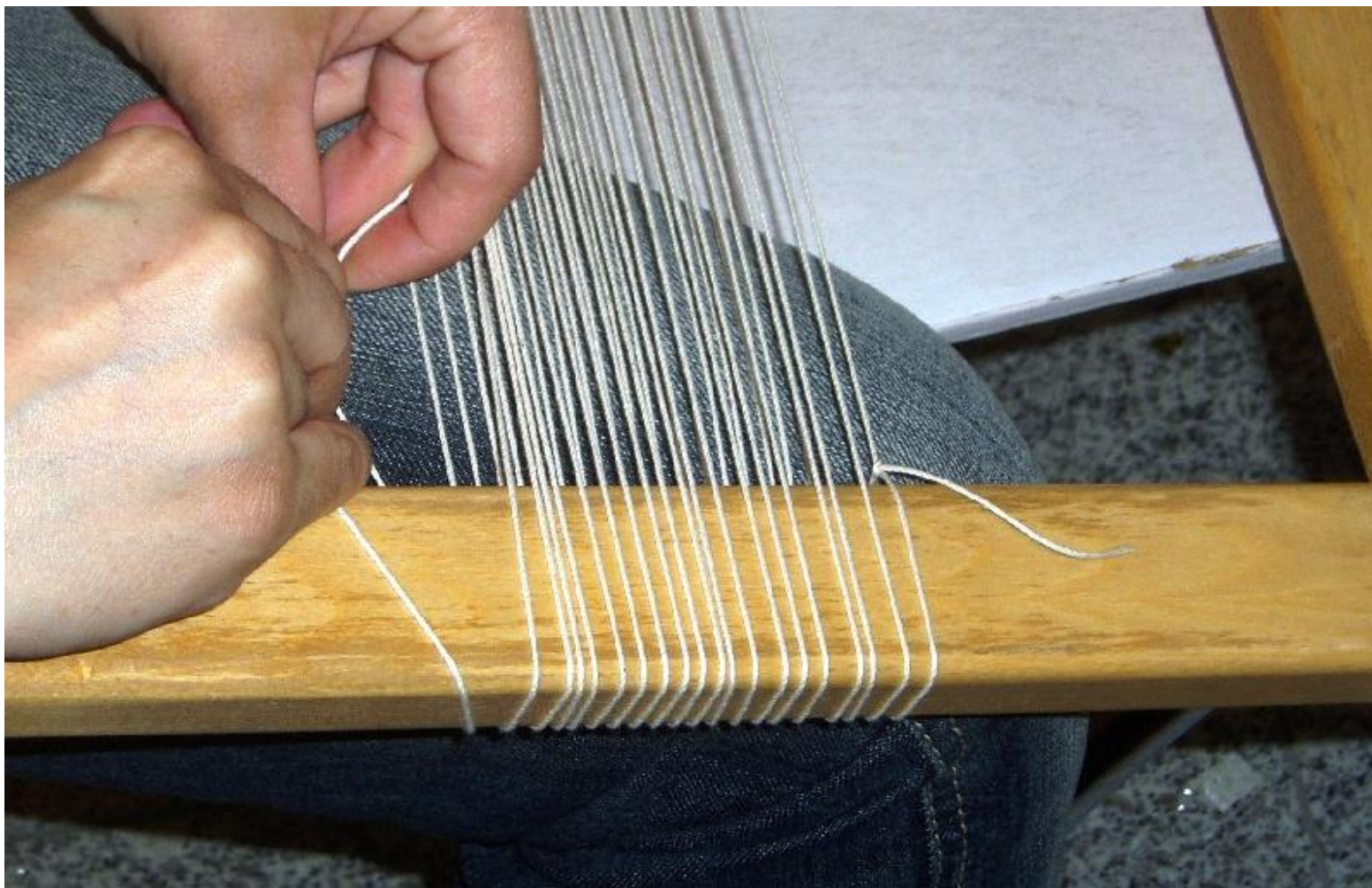

5. Raamil on 30 cm laiuselt 2-hes tasapinnas kulgev lõim.

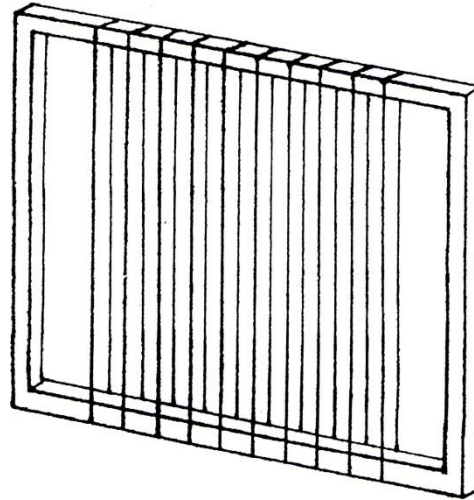

6. Vii kahe tasapinna vahelt läbi pikem laast ja lükka see raami keskele!



7. Korja iga pealmise lõimelõnga vahelt üles 1 alumine lõimelõng ja vii saadud vahelikust läbi teine pikem laast! (Kahekordsed äärelõngad jäävad kahekordseks!)

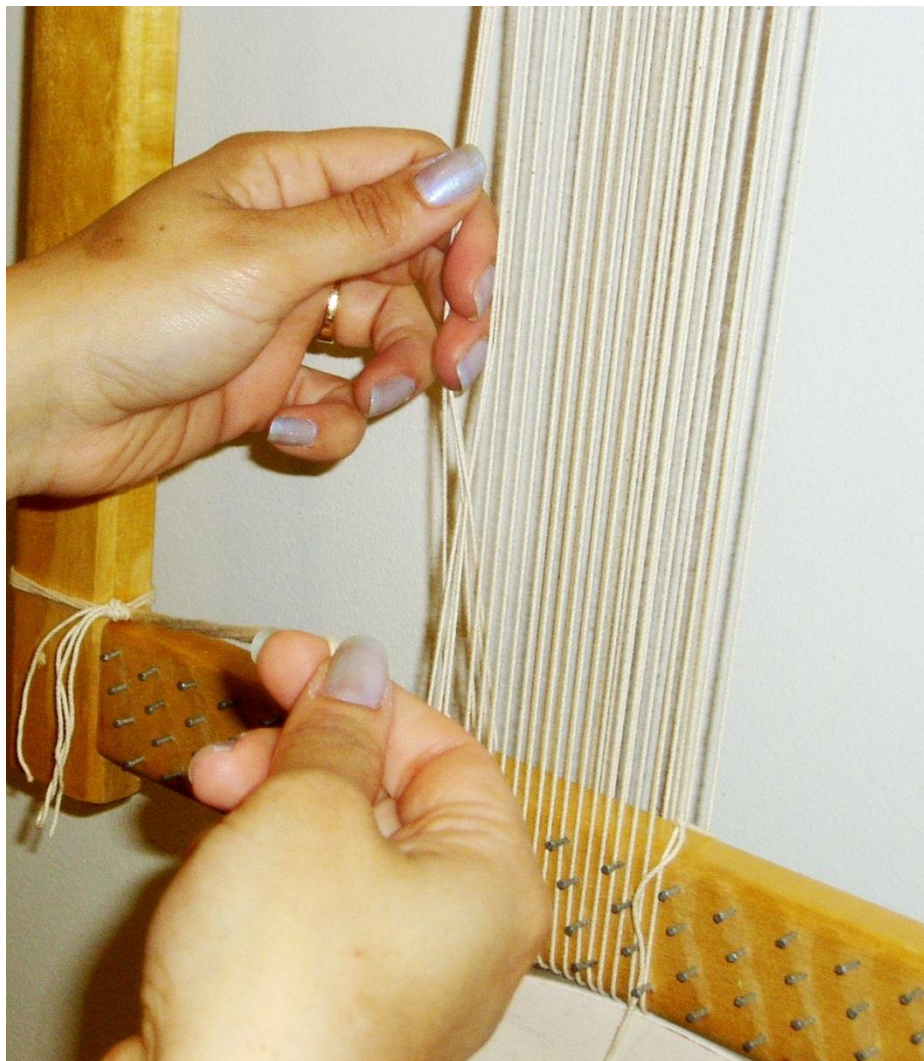

8. Heegelda teise laastu kõrvale lõimelõnga meterjalist iga lõime ümber 1 ahelsilmus nii, et moodustuks heegelahelast “SUGA”!

NB! Heegelahela algus- ja lõpuotsa nöörid jäta pikemalt vabaks, et saaksid nende abil “SOA” pingutada raami külge!

SUGA peab hoidma lõimi ühtlaste vahedega ühes tasapinnas!

EEMALDA LISALAAST!

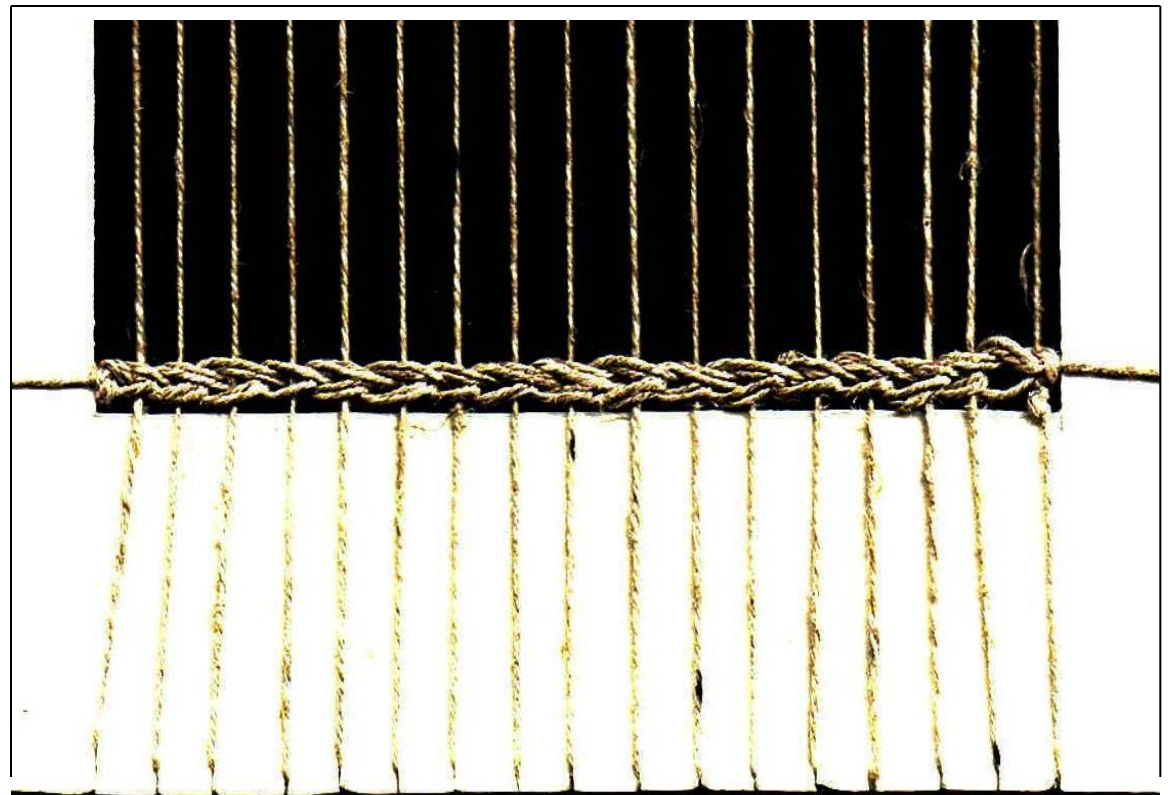
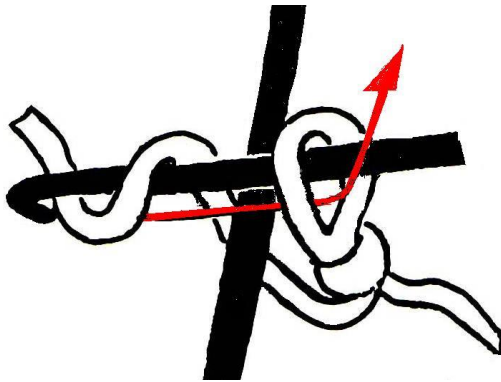

9. Korja lisalaastule ka raami teises otsas alumise tasapinna lõimed ja heegelda ning kinnita-pinguta SUGA!

NB! EEMALDA LISALAAST!

10. Nihuta mõlemad SOAD raamiotstele võimalikult lähedale!

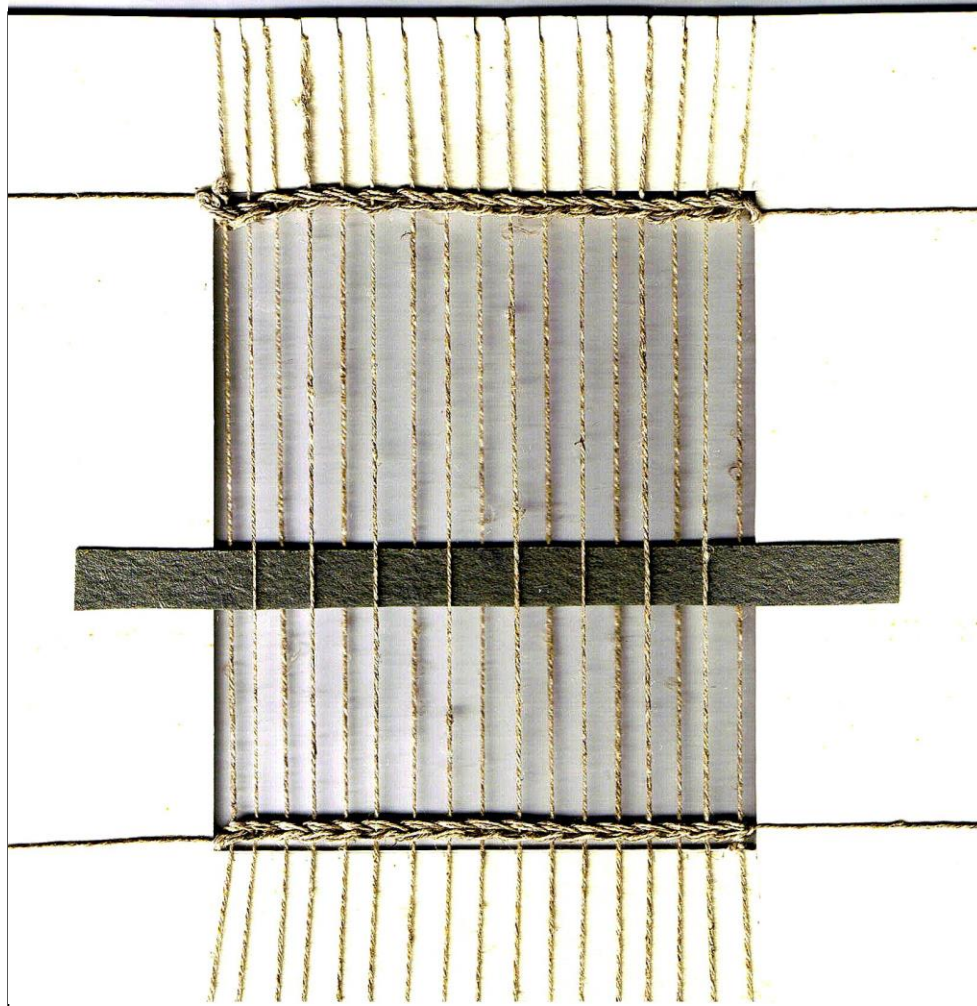

11. Esimese vaheliku avad laastu abil, mille pöörad üles!

12. Teise vaheliku avamiseks võid soovi korral valmistada NIIED.

NIIED tehakse **iga** nõ **alumise vaheliku** lõimelõnga ümber lõimematerjalist ja nad ühendatakse väiksemateks kimpudeks

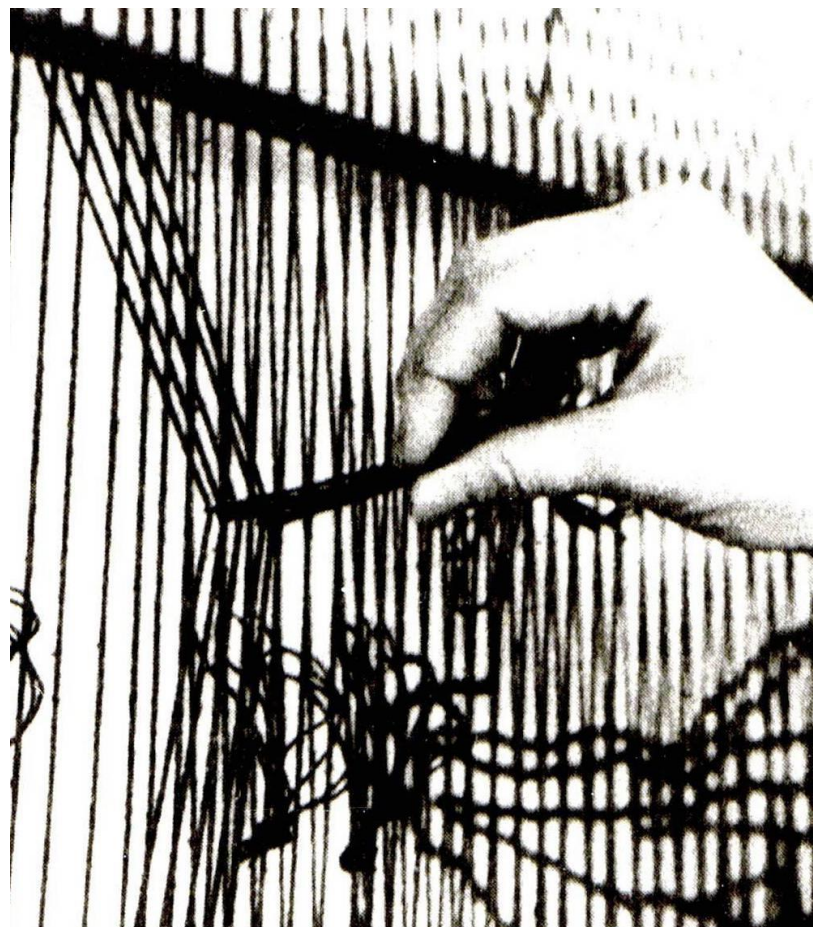
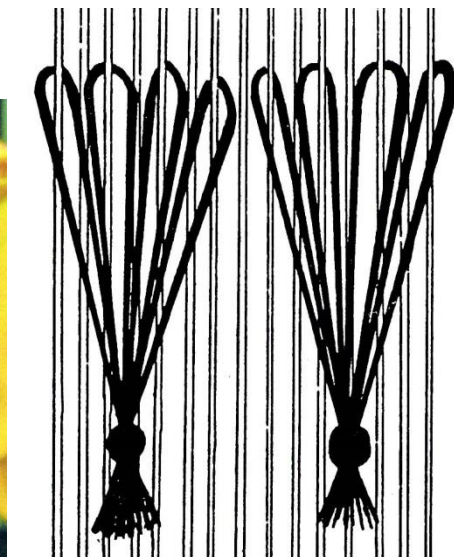
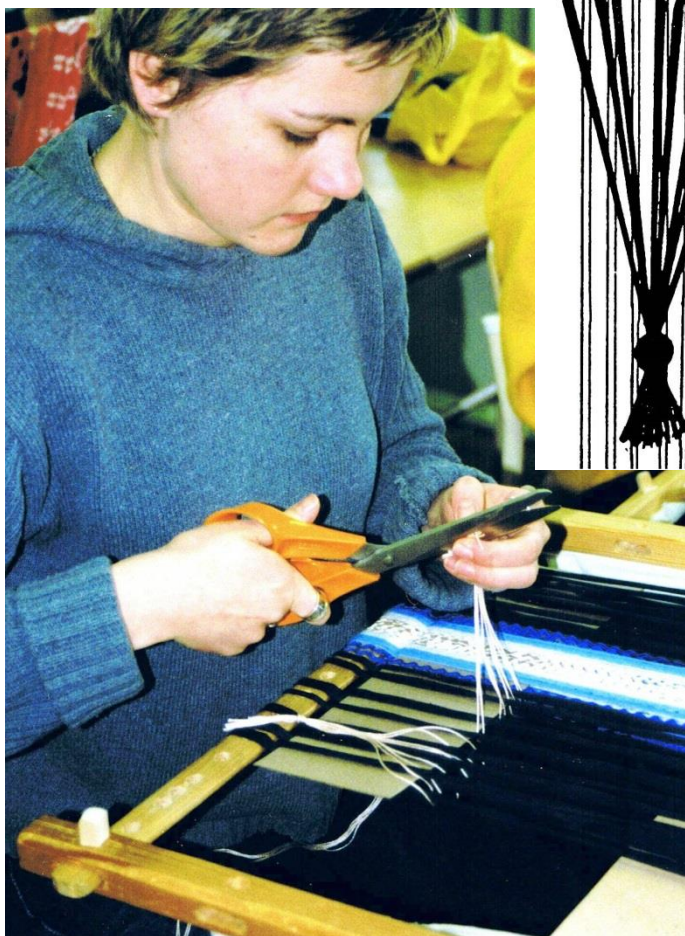

RAAM ON KUDUMISEKS VALMIS!

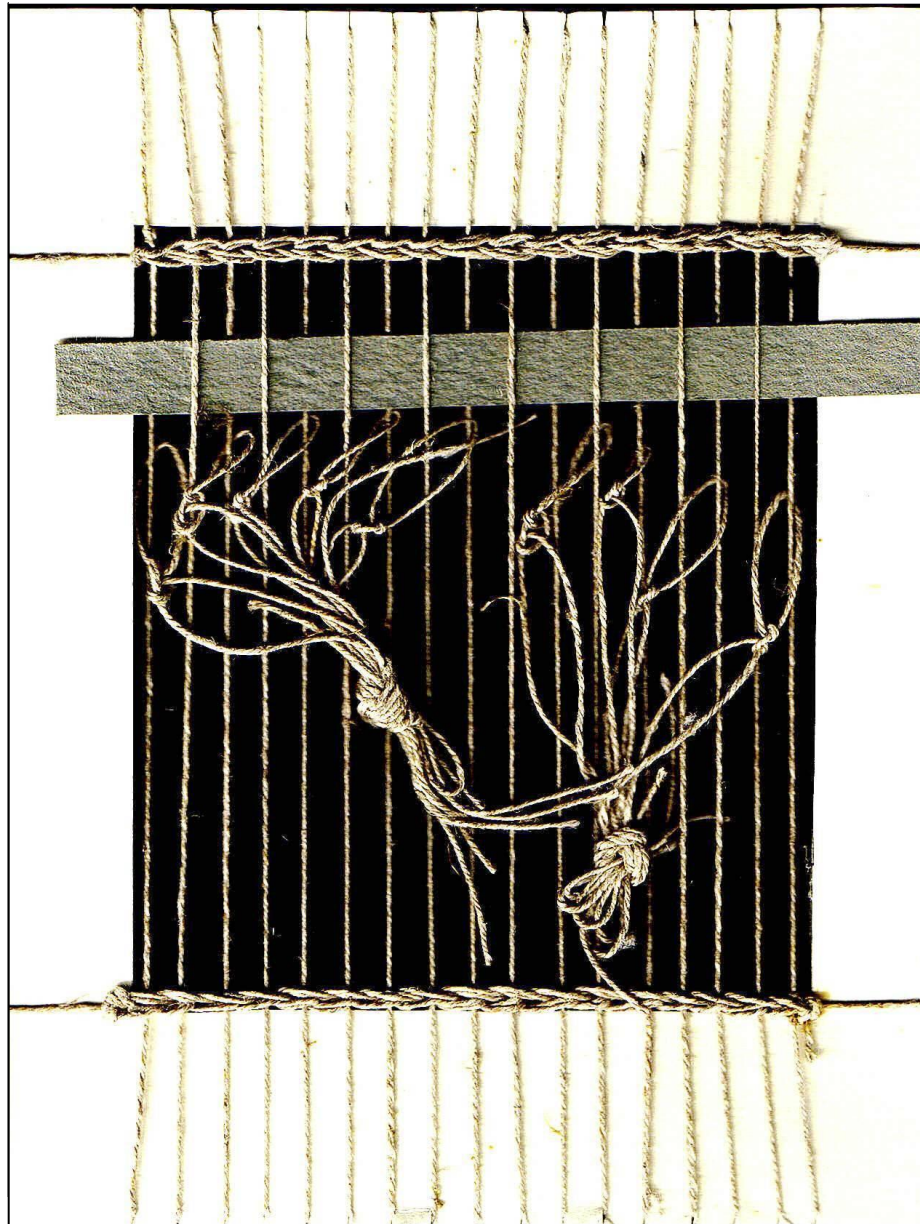

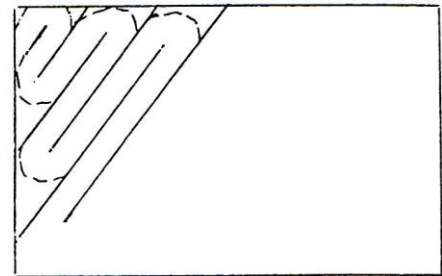
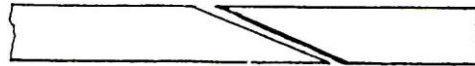
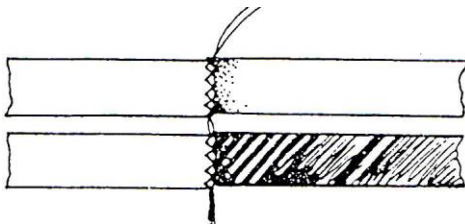
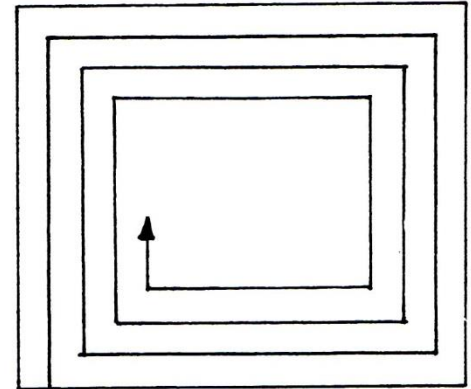
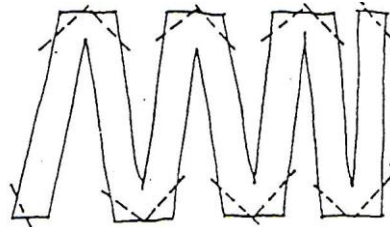
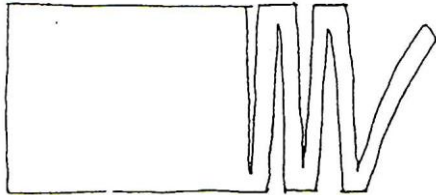
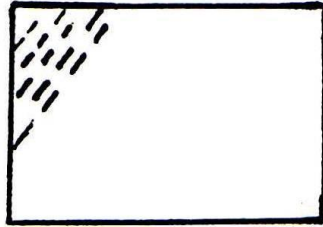
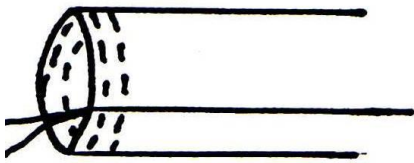
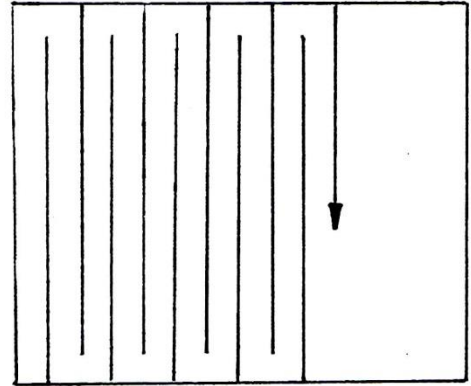
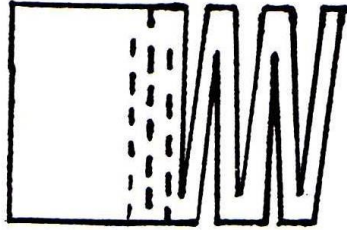
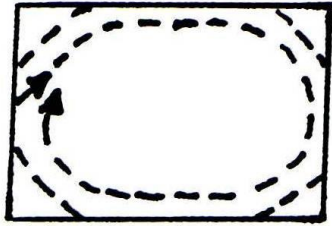

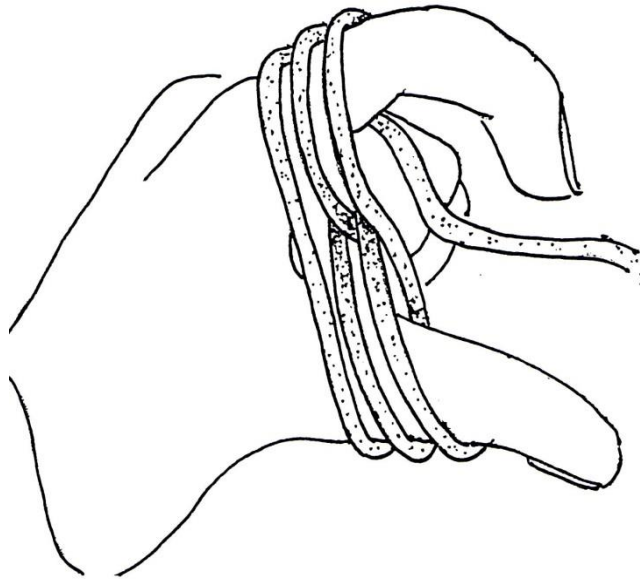
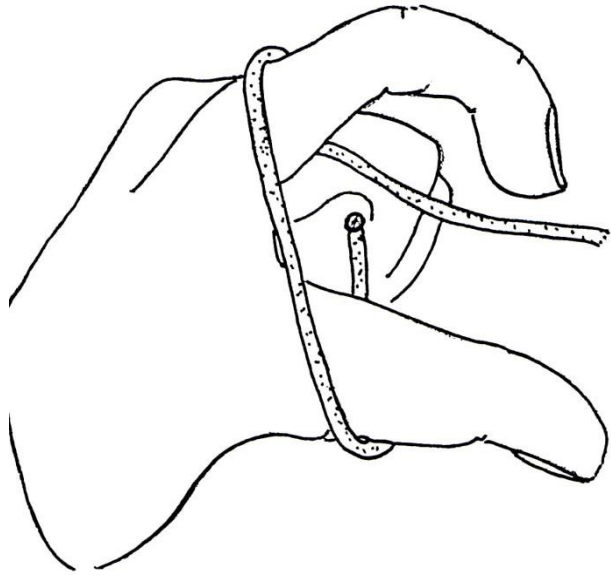

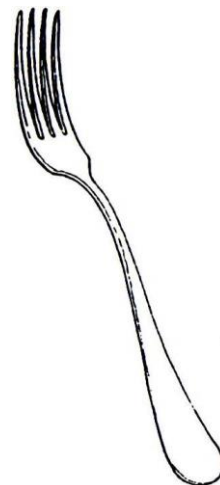
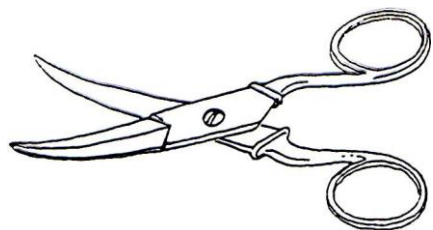
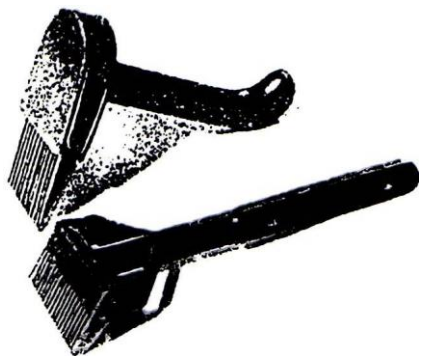
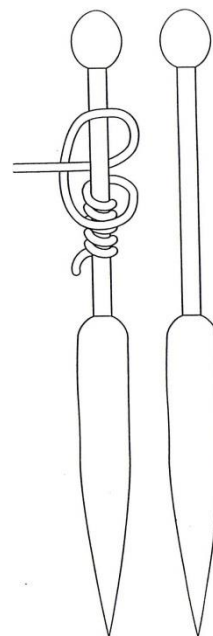
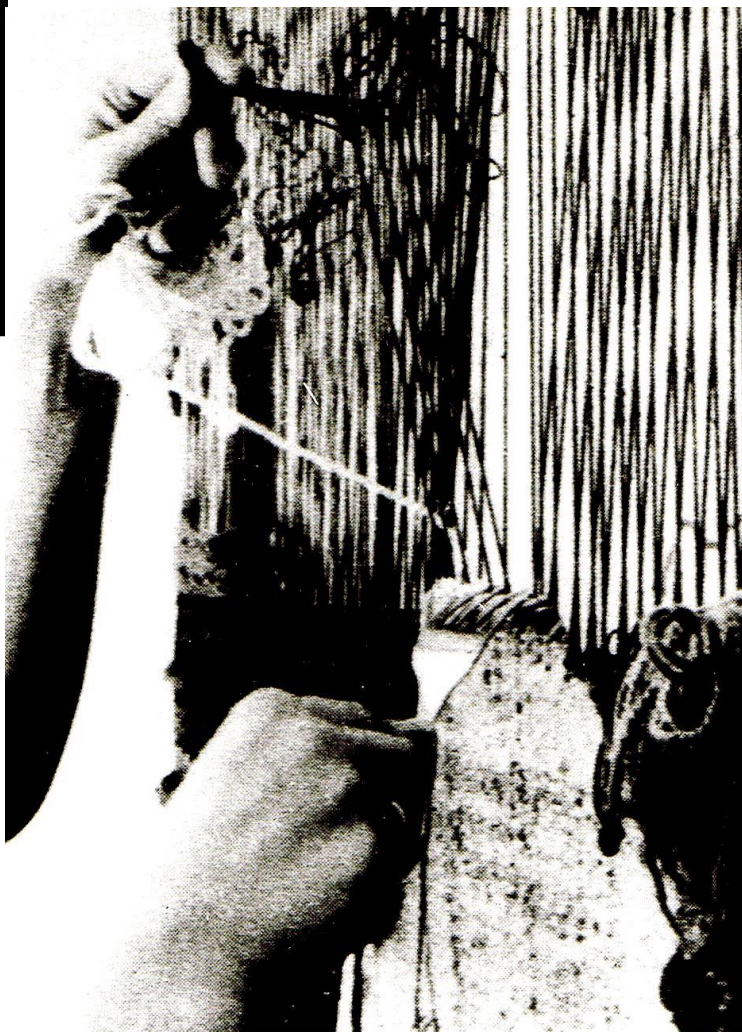
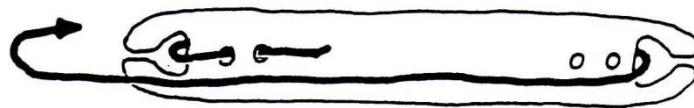
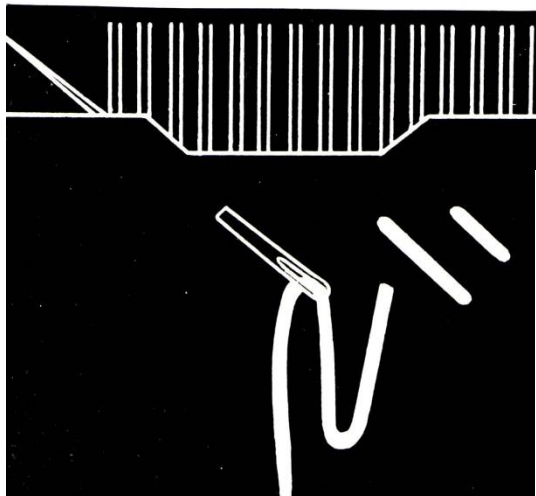

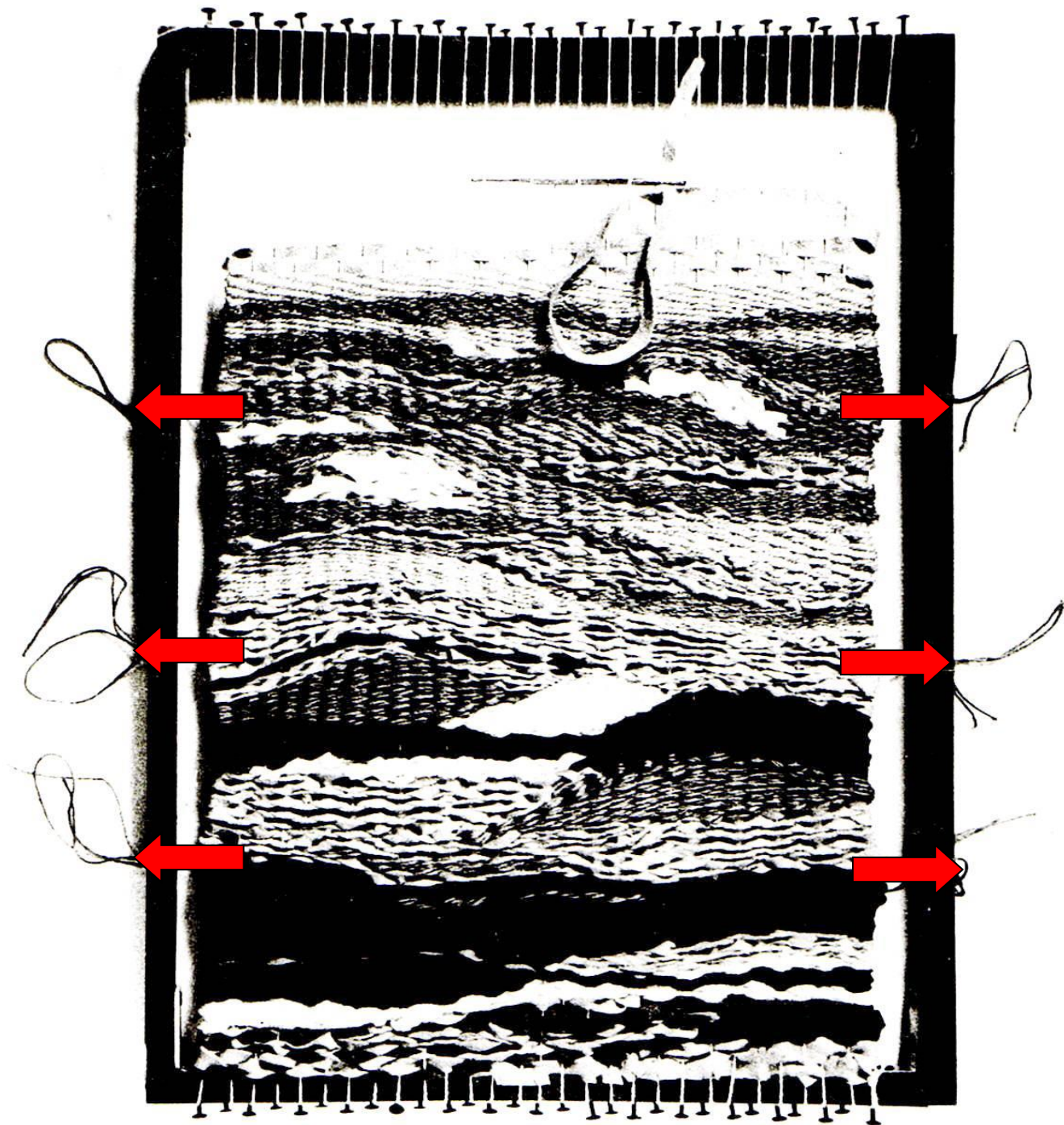

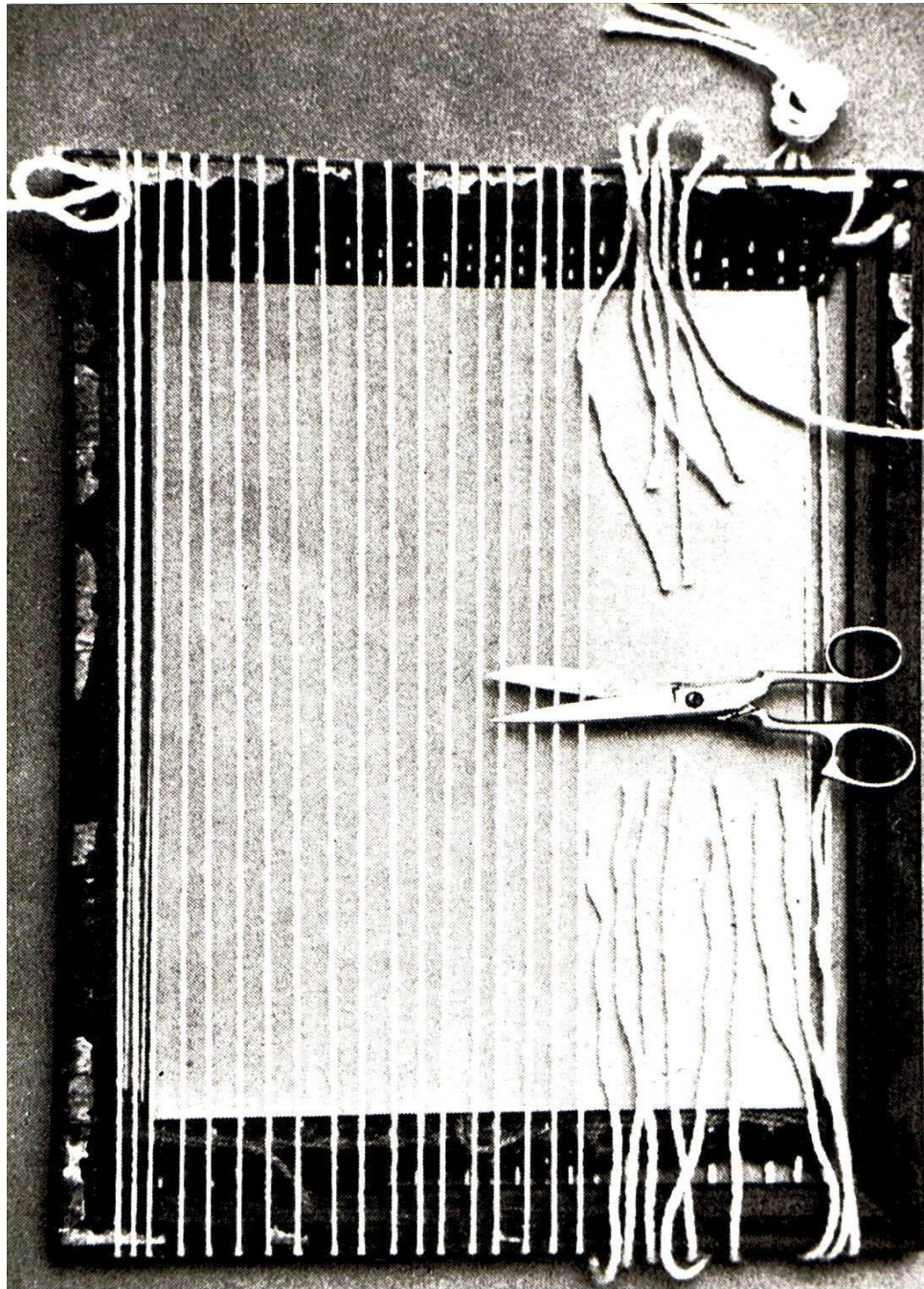

VIIMISTLUSTÖÖD

Lõpuks tasandada narmad soovitud pikkusteks.

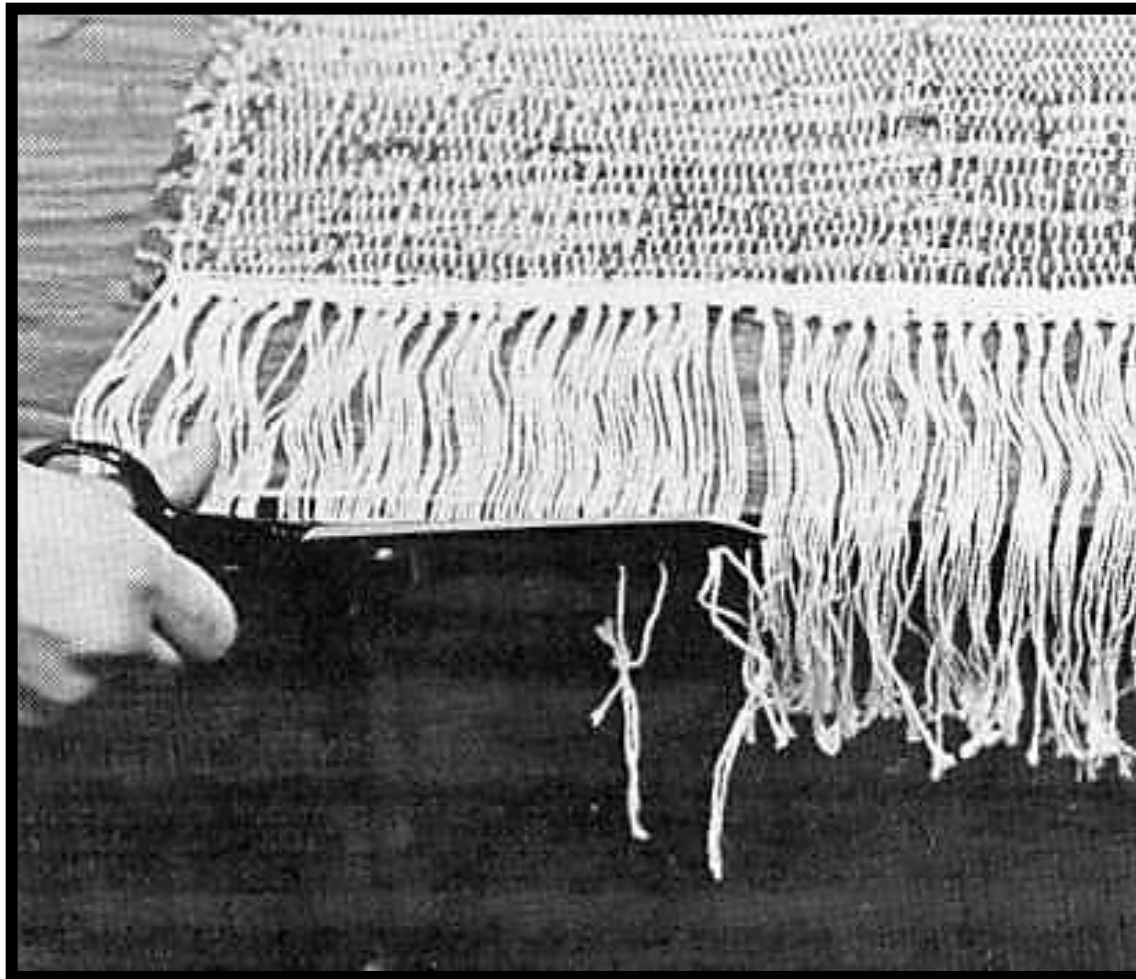

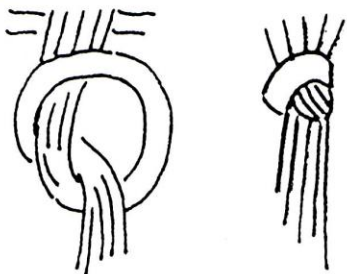

“Hobusesabasõlm”

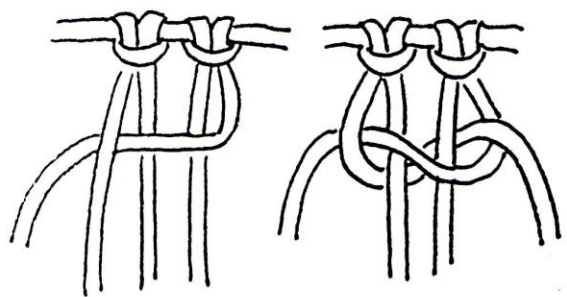
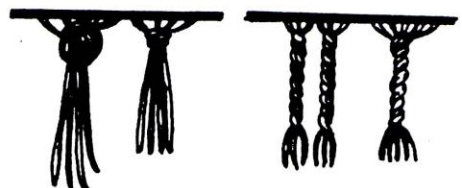
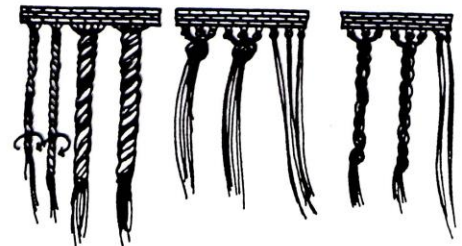

Madalsõlm

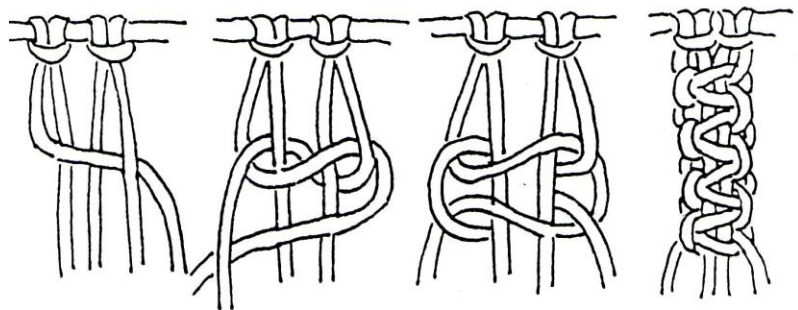
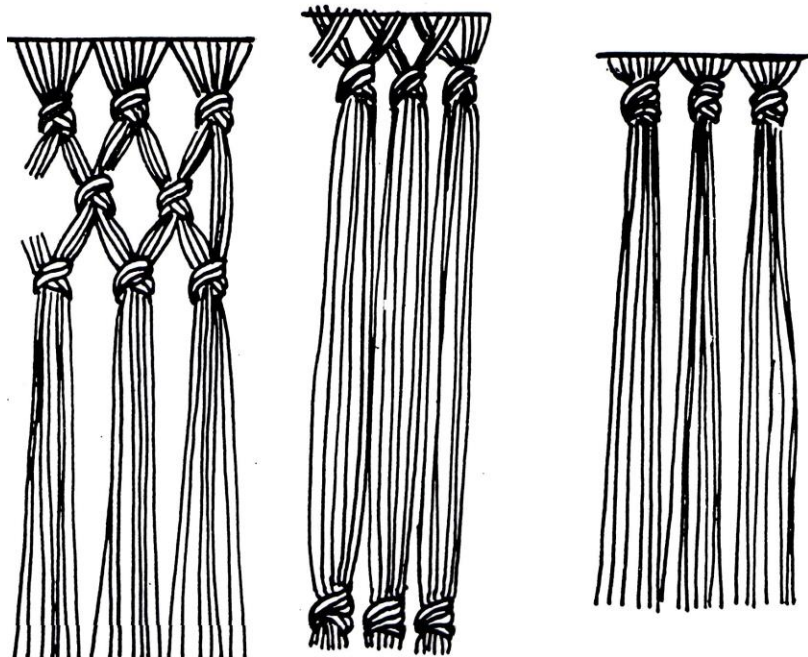

Kaksikmadalsõlm

